



FAIRBANKS CITY COUNCIL  
AGENDA NO. 2020-09  
**REGULAR MEETING – APRIL 13, 2020**  
FAIRBANKS CITY COUNCIL CHAMBERS  
800 CUSHMAN STREET, FAIRBANKS, ALASKA

---

*It is the mission of the City of Fairbanks to provide quality essential services to all City residents to ensure Fairbanks is a vibrant place to live, work, thrive, and visit.*

REGULAR MEETING  
6:30 p.m.

1. ROLL CALL
2. INVOCATION
3. FLAG SALUTATION
4. CEREMONIAL MATTERS (Proclamations, Introductions, Recognitions, Awards)
5. CITIZENS' COMMENTS, oral communications to the City Council on any item not up for public hearing. Testimony is limited to three minutes, and the comment period will end no later than 7:30 p.m. Any person wishing to speak needs to complete the register located in the hallway. Respectful standards of decorum and courtesy should be observed by all speakers. Remarks should be directed to the City Council as a body rather than to any particular Council Member or member of the staff. In consideration of others, please silence all cell phones and electronic devices.

NOTE: Due to concerns over the COVID-19 emergency, some special procedures are being implemented for City Council Meetings. Mayor Matherly and Council Members may participate telephonically during this time. Citizens may have written comments read into the record if submitted to the City Clerk in advance; the three-minute time limit applies to written testimony. To ensure compliance with Mandate 9 by Governor Dunleavy, the seating in Council Chambers has been arranged to accomplish social distancing. No more than 10 individuals will be allowed in the Chambers at the same time. Citizens arriving after the maximum number has been reached will be directed to wait in another area until it is their turn to speak to the Council. Those who are asked to wait in another area will be able to listen to the Council Meeting in progress and are asked to practice social distancing. We thank you for your understanding and cooperation during this difficult time.

6. APPROVAL OF AGENDA AND CONSENT AGENDA

Approval of Consent Agenda passes all routine items indicated by an asterisk (\*). Consent Agenda items are not considered separately unless a Council Member so requests. In the event of such a request, the item is returned to the General Agenda.

7. APPROVAL OF MINUTES OF PREVIOUS MEETINGS

- \*a) Regular Meeting Minutes of February 10, 2020
- \*b) Special Meeting Minutes of February 14, 2020

8. SPECIAL ORDERS

- a) The Fairbanks City Council will hear interested citizens concerned with the following Liquor License Applications for Renewal. Public testimony will be taken and limited to three minutes.

| Lic. # | DBA                                | License Type                       | Licensee                                     | Address                     |
|--------|------------------------------------|------------------------------------|--|-----------------------------|
| 4816   | Mayan Palace                       | Beverage Dispensary                | Taco Azteca, Inc.                            | 3401 Airport Way            |
| 3151   | Fred Meyer 485                     | Package Store                      | Fred Meyer Stores, Inc.                      | 3755 Airport Way            |
| 1059   | Raven Landing Center               | Beverage Dispensary                | Retirement Community of Fairbanks            | 949 McGown Street           |
| 54     | American Legion Post 11            | Club                               | The American Legion, Dorman H Baker Post #11 | 129 1st Avenue              |
| 5436   | Hoarfrost Distilling               | Distillery                         | Hoarfrost Distilling, LLC                    | 3501 Lathrop Street, Unit F |
| 3170   | The Odom Corporation               | Wholesale – General                | The Odom Corporation                         | 3401 Peger Road, Bay 1      |
| 4831   | Irashai Japanese Restaurant        | Restaurant/Eating Place            | 2GIRO, Inc.                                  | 419 Merhar Avenue, Suite B  |
| 4156   | Holiday #622                       | Package Store                      | Holiday Alaska, LLC                          | 2300 S. Cushman Street      |
| 1639   | Alaska Salmon Bake                 | Restaurant/Eating Place – Seasonal | Malemute, Inc.                               | 2300 Airport Way            |
| 4720   | Gallantino’s Italian Restaurant    | Beverage Dispensary                | Gallantino’s, Inc.                           | 1446 S. Cushman Street      |
| 4174   | Big Daddy’s Bar-B-Q & Banquet Hall | Beverage Dispensary                | RTG, LLC                                     | 107 Wickersham Street       |
| 5500   | K & L Distributors Alaska          | Wholesale – Malt Beverage & Wine   | White Mountain Beverage, LLC                 | 945 Elizabeth Street        |



- b) The Fairbanks City Council will hear interested citizens concerned with the following Liquor License Application for Transfer of Controlling Interest. Public testimony will be taken and limited to three minutes.

Type/License: Beverage Dispensary/License #145  
DBA: Boatel Bar  
Applicant: Abie Neubauer, Inc.  
3368 Riverside Drive, Fairbanks  
From: Boatel Bar/Abie Neubauer, Inc.  
3368 Riverside Drive, Fairbanks

- c) The Fairbanks City Council will hear interested citizens concerned with the following application for a New Marijuana Retail Store License. Public Testimony will be taken and limited to three minutes.

Type: Marijuana Retail Store, #22809  
DBA: Airport Way Best Bud  
Applicant: Airport Way Trade Center, LLC  
Address: 3598 Airport Way, Fairbanks, Alaska

- d) The Fairbanks City Council will hear interested citizens concerned with the following application for a New Marijuana Retail Store License. Public Testimony will be taken and limited to three minutes.

Type: Marijuana Retail Store, #20827  
DBA: Good Titrations  
Applicant: FSE, Inc.  
Address: 506 Merhar Avenue, Fairbanks, Alaska

- e) The Fairbanks City Council will hear interested citizens concerned with the following application for a New Standard Marijuana Cultivation Facility License. Public Testimony will be taken and limited to three minutes.

Type: Standard Marijuana Cultivation Facility, #20829  
DBA: Good Titrations  
Applicant: FSE, Inc.  
Address: 506 Merhar Avenue, Fairbanks, Alaska

- f) The Fairbanks City Council will hear interested citizens concerned with the following application for a New Marijuana Product Manufacturing Facility License. Public Testimony will be taken and limited to three minutes.

Type: Marijuana Product Manufacturing Facility, #20832  
DBA: Good Titrations  
Applicant: FSE, Inc.  
Address: 506 Merhar Avenue, Fairbanks, Alaska

9. MAYOR'S COMMENTS AND REPORT

- a) Special Reports

10. COUNCIL MEMBERS' COMMENTS

11. UNFINISHED BUSINESS

- a) Ordinance No. 6127 – An Ordinance Authorizing Conveyance of a Temporary Construction Easement on City-Owned Parcel TCE-11 as Requested by the Alaska Department of Transportation & Public Facilities for the Wendell Avenue Bridge Project. Introduced by Mayor Matherly. SECOND READING AND PUBLIC HEARING.

12. NEW BUSINESS

- \*a) Resolution No. 4908 – A Resolution Authorizing the City of Fairbanks to Accept Funding from the Bureau of Justice Assistance for the FFY2020 Coronavirus Emergency Supplemental Funding Program. Introduced by Mayor Matherly.
- \*b) Ordinance No. 6129 – An Ordinance Re-establishing an Incentive Bonus Program within the Fairbanks Police Department for Recruitment and Hiring. Introduced by Mayor Matherly and Council Member Therrien.

13. DISCUSSION ITEMS (Information and Reports)

- a) Committee Reports

14. WRITTEN COMMUNICATIONS TO THE CITY COUNCIL

15. COUNCIL MEMBERS' COMMENTS

16. CITY CLERK'S REPORT

17. CITY ATTORNEY'S REPORT

18. EXECUTIVE SESSION

19. ADJOURNMENT



FAIRBANKS CITY COUNCIL  
REGULAR MEETING MINUTES, FEBRUARY 10, 2020  
FAIRBANKS CITY COUNCIL CHAMBERS  
800 CUSHMAN STREET, FAIRBANKS, ALASKA

---

The City Council convened at 6:30 p.m. on the above date, following a 5:00 p.m. Work Session for Strategic Planning on City Services & Revenues, to conduct a Regular Meeting of the Fairbanks City Council at the City Council Chambers, 800 Cushman Street, Fairbanks, Alaska, with Mayor Jim Matherly presiding and with the following Council Members in attendance:

Council Members Present: Shoshana Kun, Seat A  
June Rogers, Seat B  
Valerie Therrien, Seat C  
Aaron Gibson, Seat D  
Jerry Cleworth, Seat E  
David Pruhs, Seat F

Absent: None

Also Present: Paul Ewers, City Attorney  
D. Danyielle Snider, City Clerk  
Jeff Jacobson, Public Works Director  
Mike Meeks, Chief of Staff  
Angela Foster-Snow, HR Director  
Nancy Reeder, Police Chief  
Jim Styers, Fire Chief  
Tod Chambers, Assistant Fire Chief

City Clerk Snider read the Mission Statement of the City of Fairbanks.

**INVOCATION**

The Invocation was given by City Clerk Snider.

**FLAG SALUTATION**

**Mayor Matherly** asked everyone to join him in the Pledge of Allegiance.

**CITIZENS' COMMENTS**

Sue Sprinkle, 211 5th Avenue, Fairbanks – Ms. Sprinkle provided the Council with an update on a couple of properties in her neighborhood. She stated that a local business was robbed, and it is likely related to the property in her neighborhood. She shared that there was another break-in at the abandoned house near her property. She asked what would happen to the dilapidated house that recently burned down and expressed concern that it may become a problem property if it remains until the following summer. She stated she is excited about the idea of a nuisance property committee, and she would like to hear from the Council about what they would like to see happen.

**Mr. Cleworth** asked when the property Ms. Sprinkle referred to burned. Ms. Sprinkle stated that she believes the house burned down in January.

Max Plichta, 1763 Iniakuk Road, Fairbanks – Mr. Plichta addressed the Council about the issue of climate change. He urged the City Council to study the effects of global warming on Earth’s climate and gave suggestions as to how to go about addressing issues.

Julie Jones, 1442 Luke Street, Fairbanks – Ms. Jones stated she is speaking on behalf of the non-profit organization, Festival Fairbanks, and she spoke about Festival Fairbanks’ shared interest in nuisance properties. She expressed support for the renewal of the Mecca Bar liquor license. She stated that the Golden Heart Plaza has had many police calls recently, and it is not simply one particular area of downtown that is the problem. She stated it is up to all citizens to put their heads together to come up with a solution to these kinds of chronic problems.

Victor Buberger, P.O. Box 58192, Fairbanks – Mr. Buberger stated he is sad about the recent deaths in the downtown area due to exposure; he shared that one of the men was a friend of his. He asked the Council to address what is really going on with the Polaris Building and how they intend to profit off the property. He suggested that the City is in with Explore Fairbanks and that it is a backdoor deal to acquire the building. Mr. Buberger stated he read that a \$200 million project was under consideration to put a performing arts center in that location; he commented that a certain Council member would be happy to chair that committee. He stated the City levies alcohol and bed tax but is keeping a secret as to what is going on with the Polaris project. He stated the building has been there for years and insinuated that Explore Fairbanks has something to hide. He stated that someone is going to make a lot of money.

David van den Berg, 332 Slater Drive, Fairbanks – Mr. van den Berg stated he is attending as the Director of the Downtown Association (DTA). He stated that the Borough has stalled completely in what could be done to help the downtown core area. He stated the City has the power to regulate on- and off-street parking, and he spoke to the importance of parking services. He stated Ordinance No. 5723 gave the authority over parking services to the Parking Authority and asked what kind of authority they actually have.

Michael Farrell, P.O. Box 61004, Fairbanks – Mr. Farrell stated he listened to the last meeting, and he thought it was inappropriate for the Mayor to tell citizens at a Council Meeting what is or is not appropriate be discussed; he stated that he would like a list of items that are not allowed to be spoken about. He stated the Mayor met someone with hostility at the last Council Meeting, and it was not appropriate. Mr. Farrell explained to the Mayor that if he intends to move up in politics he has to allow people to speak. He stated citizens should be allowed to ask any questions they wish about a huge project like the Polaris Building. He stated the public is asking about the plan, and they should be heard. He stated he saw a 300-page document relating to the project; he stated if that much has been invested in planning, there is likely something going on behind the scenes.

David Hayden, 147 3rd Avenue, Fairbanks – Mr. Hayden stated he lives in the neighborhood near American Tire and Auto and the Clay Street Cemetery; he expressed support for rewriting the local nuisance ordinance. He stated he has read Anchorage’s ordinance, and the City could adopt something similar. Mr. Hayden stated there is a house that was a nuisance all summer, but it never came up on the City’s radar until it recently burned down. He stated it should not take a crisis in

order for the City to pay attention to the area, and he mentioned the local business that was recently robbed. He stated he calls the police, makes reports, and has been talking about the problems since October, but nothing has been done to fix the problem.

**Mr. Cleworth** asked Mr. Hayden if he read the whole Anchorage ordinance and whether their ordinance is codified or just a policy. Mr. Hayden stated that the Anchorage ordinance is codified.

Hearing no more requests for comment, **Mayor Matherly** declared Citizens' Comments closed.

### **APPROVAL OF AGENDA AND CONSENT AGENDA**

**Ms. Therrien**, seconded by **Ms. Kun**, moved to APPROVE the Agenda and Consent Agenda.

**Mayor Matherly** called for objection and, hearing none, so ORDERED.

City Clerk Snider read the Consent Agenda into the record.

### **APPROVAL OF PREVIOUS MINUTES**

a) Regular Meeting Minutes of December 2, 2019.

APPROVED on the CONSENT AGENDA

### **SPECIAL ORDERS**

a) The Fairbanks City Council heard interested citizens concerned with the following Liquor License Applications for Renewal:

| <b>Lic. #</b> | <b>DBA</b>                  | <b>License Type</b> | <b>Licensee</b>             | <b>Premises Address</b> |
|---------------|-----------------------------|---------------------|-----------------------------|-------------------------|
| 710           | Mecca Bar                   | Beverage Dispensary | JRB, Inc.                   | 549 2nd Avenue          |
| 104           | Red Lantern Steak & Spirits | Beverage Dispensary | Westmark Hotels, Inc.       | 813 Noble Street        |
| 4247          | Brewster's                  | Beverage Dispensary | Restaurant Concepts, LLC    | 3578 Airport Way        |
| 4819          | The Antler Room             | Beverage Dispensary | The Antler Room, Inc.       | 1003 Pioneer Road, #A   |
| 5169          | HooDoo Brewing Company      | Brewery             | Fairbanks Fermentation, LLC | 1951 Fox Avenue         |
| 4168          | Food Factory                | Beverage Dispensary | CNR Enterprise, LLC         | 275 Bentley Trust Road  |

**Ms. Kun**, seconded by **Mr. Gibson**, moved to consider the Mecca Bar Liquor License Application for Renewal separately from other renewal applications.

**Mayor Matherly** called for objection to considering the Mecca Bar Liquor License Application for renewal separately from other renewal applications, and hearing none, so ORDERED.

**Mr. Pruhs**, seconded by **Ms. Kun**, moved to consider The Antler Room Liquor License Application for renewal separately from other renewal applications.

**Mr. Pruhs** declared a conflict of interest as a member of the Elk's Lodge and stated he would like to abstain from voting on The Antler Room liquor license renewal application. **Ms. Therrien** stated she is also an Elks Lodge member and may have a conflict.

City Attorney Paul Ewers advised that if Council Members are only general members of the Elks Lodge, it would not preclude them from voting on the liquor license renewal.

**Mr. Pruhs** stated he would be abstaining from the vote. **Mayor Matherly** advised Mr. Pruhs that there was no conflict and that he could vote. **Mr. Gibson** stated that he is also an Elks member.

**Mayor Matherly** stated that Attorney Ewers' advice stands, and if Council Members are only general members of the organization and are not benefiting monetarily, there is no conflict.

**Mayor Matherly** called for objection to considering The Antler Room Liquor License Application for renewal separately from other renewal applications, and hearing none, so ORDERED.

**Mr. Pruhs**, seconded by **Ms. Therrien**, moved to WAIVE PROTEST on the HooDoo Brewing Company, Food Factory, Brewster's, and Red Lantern Steak & Spirits Liquor License Applications for Renewal.

**Mayor Matherly** called for public comment and, hearing none, declared Public Testimony closed.

A ROLL CALL VOTE WAS TAKEN ON THE MOTION TO WAIVE PROTEST ON THE HOODOO BREWING COMPANY, FOOD FACTORY, BREWSTER'S, AND RED LANTERN STEAK & SPIRITS LIQUOR LICENSE APPLICATIONS FOR RENEWAL AS FOLLOWS:

YEAS: Cleworth, Pruhs, Rogers, Kun, Gibson, Therrien  
NAYS: None

**Mayor Matherly** declared the MOTION CARRIED.

**Ms. Kun**, seconded by **Mr. Pruhs**, moved to WAIVE PROTEST on The Antler Room Liquor License Application for Renewal.

**Mayor Matherly** called for public comment and, hearing none, declared Public Testimony closed.

A ROLL CALL VOTE WAS TAKEN ON THE MOTION TO WAIVE PROTEST ON THE ANTLER ROOM LIQUOR LICENSE APPLICATION FOR RENEWAL AS FOLLOWS:

YEAS: Pruhs, Therrien, Kun, Cleworth, Gibson, Rogers  
NAYS: None

**Mayor Matherly** declared the MOTION CARRIED.

**Ms. Therrien**, seconded by **Mr. Pruhs**, moved to WAIVE PROTEST on the Mecca Bar Liquor License Application for Renewal.

Serena McCormick, P.O. Box 753171, Fairbanks – Ms. McCormick stated she is a bartender at the Mecca Bar; she stated she attends college classes during the day and works mostly at night. She stated she attended a Council Meeting two years ago for the liquor license renewal, and she invited Council Members to visit the bar for a tour; she stated that only two members have come in. She stated there is a problem in Fairbanks, but it is a community issue – not a license issue. Ms. McCormick stated there are times when a person is drunk and instead of leaving them lying half naked outside in subzero temperatures waiting for the service patrol to arrive, she allows them to warm up inside until help arrives. She stated two people have recently frozen to death, and she does not want that to continue to happen. She stated the Mecca Bar is the oldest bar in Fairbanks, and it has been at its original location for 74 years. She stated she is happy to be part of Fairbanks history.

Julie Jones – Ms. Jones stated the Mecca Bar is a great, downtown historic place to visit and is also a gaming location for Festival Fairbanks. She stated the Mecca Bar generates nearly \$70,000 for Festival Fairbanks, and they are hoping to use those funds to purchase cameras with recording capability at the Golden Heart Plaza. She stated that cameras should help the Fairbanks Police Department (FPD) and Public Works identify who is doing the damage at the Golden Heart Plaza. She stated they used to have webcams downtown that the police had access to, and it would be nice to have tools like that to combat the community problem that is only getting worse.

Tiffany Ayers, 2576 Linda Lane, Fairbanks – Ms. Ayers stated she is the owner of River City Café in the Co-op Plaza and shared that, including the Mecca Bar, there are nine establishments that serve alcohol on 2nd Avenue. She stated people who stumble out of the Mecca Bar come to her shop and disrupt her patrons, and she caters to tourists. She stated she employs young people who are still in high school, and her employees should not have to deal with drunk patrons from the Mecca Bar. Ms. Ayers stated a 17-year-old employee had to deal with a drunk individual who came into her establishment and took off all his clothes before passing out in the middle of the restaurant. She stated it is worse for people whose businesses within close proximity to the Mecca Bar, and she feels badly for them. She stated it was not as bad when her shop was just a little further down the street at 523 2nd Avenue. Ms. Ayers stated her boyfriend will not even come down to visit at her business because the people outside the Mecca Bar ask for rides, and when he has refused, they have told him they would steal his car. She stated she deals with the problems, but she is tired of dealing with the harassment of Mecca Bar patrons.

Larry Hackenmiller, 518 Farmers Loop Road, Fairbanks – Mr. Hackenmiller stated he sees people getting kicked out of the Mecca Bar and stated it is illegal to serve alcohol to an intoxicated person. He stated the employees at the Mecca Bar are diligent about kicking out people who come into the establishment already intoxicated. He stated Jodi has worked tirelessly and in harmony with the FPD to keep her business on the up-and-up. Mr. Hackenmiller stated that when the City came up with the alcohol tax it was intended to help deal with the community problem, but the revenue is not being used for that purpose. He spoke in support of the Mecca Bar liquor license.

Aly Rasley, 1161 Shypoke Drive, Fairbanks – Ms. Rasley stated she was a magistrate for 28 years. She stated she is familiar with the alcohol problem in the community because she was the

arraignment officer for many cases involving alcohol. She stated that cameras in the downtown core area will help combat the issue better than shutting down the Mecca Bar. She stated cameras would aid a short-staffed police department. Ms. Rasley stated the problem is with people buying alcohol at liquor stores and drinking it in the GHP, the Catholic parking lot, and other areas. She stated this is a community issue that is not caused by the Mecca Bar liquor license.

**Ms. Therrien** asked about a task force that Ms. Rasley was a part of. Ms. Rasley stated that when the City and mental health professionals work together, a lot can be done. She stated the program was successful because there was a lot of cooperation between entities; she indicated that is not how things are working anymore.

Kelly Locker, 129 1st Avenue, Fairbanks – Ms. Locker spoke in support of the Mecca Bar. She stated it has been a great place to work for 15 years, and she has never felt unsafe there. She stated people who get kicked out are intoxicated upon arrival, but when it is -40 degrees, it is wrong to put an intoxicated person who cannot stand onto the street. She questioned what they are supposed to do when the Emergency Service Patrol (ESP) will not take them and 9-1-1 will not respond.

Robert Fox, 843 5th Avenue, Fairbanks – Mr. Fox stated he works on 2nd Avenue, and he will not blame the Mecca Bar for the problems; he stated, however, that the business is a magnet for problems downtown. He stated often times he escorts people down the street who do not feel comfortable walking past the establishment alone. Mr. Fox stated there is often vomit and urine along the street that is not cleaned up. He stated that his business takes care of their little area, but they do not clean up other areas down the street. He stated the police will not respond because there is no money in it for the City. He stated he has had to get face-to-face with patrons from the Mecca Bar. He commented that the City should either shut the bar down or do what is needed to deal with the problems. He stated that patrons sometimes scare tourists, and the problem should be addressed by having a police presence downtown.

Kemp Lankford, 929 Cranberry Ridge, Fairbanks – Mr. Lankford stated he owns Aurora Apothecary next to the Mecca Bar. He stated alcoholism is a real problem, and it would be wrong for him to blame one bar for all of the problems. He reaffirmed that it is a community issue and that the City of Fairbanks is too good for this. He commented that revoking the liquor license will not solve the problem. He stated he does not believe the camera project is ever going to come to fruition and suggested that a mental health court might be a better way to combat the problem.

Rina Kowalski, Fairbanks – Ms. Kowalski stated the Mecca Bar has a terrible reputation for overserving people and a terrible staff. She spoke to a situation that occurred at the Mecca Bar when Ms. Locker was working that made her and her partner so uncomfortable they had to leave. She stated she has seen Ms. Locker overserve patrons to the point that they cannot walk, and that is wrong. She stated that the business is a nuisance to the community and asked the Council not to support renewal of the liquor license.

Victor Buberger – Mr. Buberger stated people confront him outside the Mecca Bar and in front of the Co-op Plaza, but in the old days there were always officers on patrol. He stated there used to be better control, and it is wrong to fault business owners for a problem much bigger than themselves.



Jodi Blakley, 2000 Patricia Court, Fairbanks – Ms. Blakley stated she has worked very hard to follow rules and make the Mecca Bar a welcoming place. She stated they do not allow intoxicated individuals in, and the only exception is when it is freezing outside, and a person is passing out on the street. She stated they had a customer who died from exposure. She stated the cameras are paid for and will be installed in the near future.

**Mr. Gibson** asked Ms. Blakley how long she had owned the bar; Ms. Blakley stated 13 years.

**Ms. Therrien** asked Ms. Blakley for her thoughts about the accusation that her bartenders overserve patrons. Ms. Blakley stated that if it happens, it happens rarely. She stated her staff takes care of Mecca Bar customers. **Ms. Therrien** asked whether the list of those who are not allowed in the bar grows each year. Ms. Blakley stated that once a person is on the list, their name does not come off. She stated, however, that once a year they go through the list and cross off names of those who have passed away.

**Ms. Kun** asked Ms. Blakley if she could hire a security guard. Ms. Blakley stated that a security guard would not be able to enforce anything outside, so their only function would be to do ID checks; she stated that would be redundant because the bartenders already do that.

**Ms. Rogers** asked Ms. Blakley what she meant when she said police officers do not come to 2nd Avenue anymore. Ms. Blakley stated that the police used to do regular walk-throughs at the bar, but they have gotten away from that. She stated she would be happy to have officers park in front of her bar while they do paperwork, just to establish a presence.

Travis Davis, P.O. Box 58265, Fairbanks – Mr. Davis stated that in all his years in Fairbanks he has never heard of a major shooting or stabbing at the Mecca Bar. He spoke in support of the liquor license renewal.

David van den Berg – Mr. van den Berg stated the Mecca Bar puts the DTA in an awkward spot because there is definitely a social problem, but there are also problems with the establishment. He stated it negatively affects the businesses downtown.

Debra Babcock, P.O. Box 55764, North Pole – Ms. Babcock stated her son was a chronically inebriated person who was a Mecca Bar customer; she shared that he passed away. She stated the Mecca is giving money to the DTA, and it is helping increase alcohol abuse. She stated it hurt to hear Ms. Blakley say that they go through their list and cross off those who have died.

Hearing no more requests for comment, **Mayor Matherly** declared Public Testimony closed.

**Mayor Matherly** pointed out that there were no department-recommended protests for the license.

**Mr. Cleworth** stated he owns the building next to the Mecca Bar, and he has a conflict of interest. He stated he would abstain from discussion and the vote on the Mecca Bar liquor license renewal.

**Ms. Rogers** asked Police Chief Reeder to provide a staff report on callouts. Chief Reeder stated a lot of calls on the list are not related to the license, but the address was used to direct police to the incident location. She stated that sometimes incidents are on the street or in parking lots.

**Mayor Matherly** spoke to the limited resources at the City – especially at FPD. Chief Reeder stated there are now eight vacancies in her department, and five officers intend to retire soon. She stated they have been trying to hire officers, but it is difficult to find qualified applicants. She stated FPD officers are call-driven and have no unobligated time.

**Mr. Gibson** asked about the 16 calls for service referenced by Chief Reeder. Chief Reeder stated she went through the entire list for the Mecca Bar, but only 14 of the calls were cause for concern. She stated the location is often used as a reference point for calls for service, but calls may not be related to the license.

**Ms. Therrien** asked if it would be possible to have a bigger police presence downtown. Chief Reeder stated there are a lot of neighborhoods that would like to have more police presence, but it is not feasible at this time. She stated that she would like to have a couple officers on bicycle patrol downtown in the summer, but with staffing levels as they are now, it is not feasible.

**Ms. Rogers** stated it is going to take everyone working together to find solution to the problems facing the community. She stated a lot of light has been shone on community issues throughout the meeting, and they are problems that are not easily fixed. She stated she was encouraged to hear people agree that it is a community issue; she stated she will be voting to support the liquor license renewal, and she thanked all those who attended and spoke about the issue.

**Ms. Therrien** stated that the chronic inebriate issue needs to be addressed in the goals of the City and that taking away the Mecca Bar is not going to solve the problem. She stated that the problem would just shift to another establishment. She stated she would like to see more of a police presence in the downtown area during the summer, but the bigger topic that needs to be addressed is the issue of chronic inebriates.

**Mayor Matherly** stated he has been working with the Chief of Staff on public inebriation and loitering issues because he does not want the problem to deter tourism. He stated his heart goes out to Ms. Babcock; he stated it is a sad statistic that Alaskans are not proud of. He stated alcohol is a major problem in Alaska, and he is working on a few different solutions at the ground level. He stated he will work with Chief Reeder on regulation and enforcement.

**Ms. Kun** stated she is a substance abuse counselor, and there is a need for the City to admit there is a problem. She stated she used to patronize the Mecca Bar when she was a care worker because one of her clients liked to go to the bar. She stated overserving is a very real issue, and she has received calls from citizens who want the Mecca Bar to be shut down. She stated that when she was running for office, a gentleman asked her to have the bar shut down. She stated that the man said he is a relapsing drug addict, and he can go to the Mecca Bar anytime and pick up any drug of his choice. She stated she would not vote in support of the liquor license renewal.

**Mr. Pruhs** stated there were some disparaging comments made about a fine person who works at the Mecca Bar, and he does not appreciate hearing such things about a good person.

**Mr. Gibson** stated he understands the downtown has issues, but it is the Council's job to address those issues – not the license holder's job.

A ROLL CALL VOTE WAS TAKEN ON THE MOTION TO WAIVE PROTEST ON THE MECCA BAR LIQUOR LICENSE APPLICATION FOR RENEWAL AS FOLLOWS:

YEAS: Therrien, Rogers, Pruhs, Gibson

NAYS: Kun

ABSTAIN: Cleworth

**Mayor Matherly** declared the MOTION CARRIED.

**Mayor Matherly** called for a brief recess. The meeting resumed following the short recess.

- b) The Fairbanks City Council heard interested citizens concerned with the following Application for a New Marijuana Product Manufacturing Facility License:

Type/License: Marijuana Product Manufacturing Facility, License #14874

DBA: GoodSinse, LLC

Applicant: GoodSinse, LLC

Location: 2604 Davis Road, Fairbanks

**Ms. Therrien**, seconded by **Ms. Kun**, moved to PROTEST the New Marijuana Product Manufacturing Facility License until a Certificate of Occupancy is issued by the Building Department.

**Mayor Matherly** called for public comment and, hearing none, declared Public Testimony closed.

A ROLL CALL VOTE WAS TAKEN ON THE MOTION TO PROTEST THE NEW MARIJUANA PRODUCT MANUFACTURING FACILITY LICENSE UNTIL A CERTIFICATE OF OCCUPANCY IS ISSUED BY THE BUILDING DEPARTMENT AS FOLLOWS:

YEAS: Rogers, Gibson, Therrien, Pruhs, Cleworth, Kun

NAYS: None

**Mayor Matherly** declared the MOTION CARRIED.

### **MAYOR'S COMMENTS AND REPORT**

**Mayor Matherly** stated that Jo Scott has been in his thoughts because her husband Dick passed away recently. He spoke to the events he attended since the last City Council Meeting.

### **COUNCIL MEMBERS' COMMENTS**

**Ms. Therrien** stated she looks forward to working on the nuisance property ordinance and shared that it is time for the Council to find a resolution to that issue.

**Mr. Gibson** thanked Mr. Plichta for attending and speaking to the Council about climate change, and he encouraged him to continue his work. He shared some things the City is doing to reduce its carbon footprint and energy usage.

**Mr. Pruhs** encouraged Mr. Buberger and Mr. Farrell to stay so he could address their comments later on in the meeting when he provides an update on the Polaris Work Group.

**Ms. Rogers** echoed Mr. Gibson’s comments and stated the City could put climate change information on the City website.

**Mr. Cleworth** stated that LED lighting has saved the City 50% on their light bill; he stated the City does its best to use as few resources as possible. He addressed Mr. Buberger’s earlier comments and shared that the Council approved a resolution within the past six months addressing what might happen with the Polaris Building property.

**Ms. Rogers** applauded Mr. Cleworth his efforts in the historical restoration of City Hall.

**UNFINISHED BUSINESS**

- a) The Fairbanks City Council addressed the following Liquor License Application for Renewal. POSTPONED from the Regular Meeting of January 27, 2020; public hearing was held at that time.

| Lic. # | DBA             | License Type  | Licensee            | Premises Address    |
|--------|-----------------|---------------|---------------------|---------------------|
| 1134   | Thrifty Liquors | Package Store | Market Basket, Inc. | 1410 Cushman Street |

*At the Regular Meeting of January 27, 2020, Ms. Kun, seconded by Mr. Gibson, moved to PROTEST the Thrifty Liquors liquor license application for renewal. The motion to protest remained on the floor.*

The Council requested to hear from the liquor license applicant.

Rudy Gavora, P.O. Box 70021, Fairbanks – Mr. Gavora stated he has never had to come before the Council for an existing liquor license – only when there was a new license or the transfer of a license. He stated he is somewhat offended. He stated the City has no problem taking millions of dollars in tax revenue from the location. He stated that they have been operating in Alaska for 60 years, and they have had package store and beverage dispensary licenses throughout the state. He stated they have always been a responsible retailer and have never lost the ability to sell at any of their stores, putting their record above any other chain in the State of Alaska. Mr. Gavora stated they have never gone through these kinds of proceedings with any other municipality. He stated his employees are trained through the Training for Alcohol Professionals (TAPS) Program. He stated that the Council is asking \$15-an-hour clerks to do law enforcement work. He explained that their job is to control liquor sales at the point of sale under the regulations of the State of Alaska Alcoholic Beverage Control (ABC) Board. He stated his employees do a great job, but they cannot control consumptions once a person leaves the business. He stated they sell to mostly sober people, and they have internal incident reports and “no-sell” lists. Mr. Gavora stated the 95 calls reported to the Council cannot be quantified as having direct correlation with the liquor store; he stated he spoke with City Dispatch. He explained that the majority of the calls were during summer months. He spoke about his service on former Mayor Strle’s Chronic Inebriate Task Force

and to how things were done at that time. He stated that people are trying to blame everything on alcohol, but there are much bigger problems. He stated the City is happy to embrace its new revenue partner “with the leaves”. He asked whether anyone has looked at the “zombie culture” at night when liquor establishments are closed; he stated they are the ones out at night causing trouble.

**Mr. Pruhs** asked for confirmation that the Gavora family had been in the liquor business since the 1960’s; Mr. Gavora confirmed. **Mr. Pruhs** asked whether they ever had a license pulled, and Mr. Gavora replied that they have not. **Mr. Pruhs** stated that there are many less liquor stores and bars in Fairbanks than there used to be, so there is a condensed group of people patronizing a smaller number of locations. Mr. Gavora stated the DTA has done a great job of pushing it out to other locations; he mentioned that Bentley Mall, Gavora Mall, and Fred Meyer East are affected by the same issues. **Mr. Pruhs** asked Mr. Gavora about the stores he currently owns and operates. Mr. Gavora stated they six stores in the Borough, three of which are in the City.

**Ms. Therrien** stated that when she drives near the location, she sees people loitering and drinking in the parking lot. She asked Mr. Gavora if he could offer any solutions. Mr. Gavora stated that he disagrees with Ms. Therrien and that he is there sometimes three times in one day. He stated that security guards and employees chase people off the property and that it is not necessarily his property where the people are congregating. Mr. Gavora stated that people also hang out on property near Stacia Street and that the liquor store is in close proximity to chronic inebriate housing. He stated the liquor store was there long before the facility. He indicated that alcohol problems are less now than they used to be and that there are about 60 chronically inebriated people causing the problem. He stated that his business pays millions of dollars to the City in alcohol and property taxes, and he asked what the funds were being spent on.

**Mr. Gibson** asked Mr. Gavora if he knew his liquor license renewal would be considered by the Council at the last meeting. Mr. Gavora stated that he was not aware and that he has never had to deal with an issue like this before.

**Ms. Kun** asked whether the TV at the location is ever turned off; she stated it is very bright. Mr. Gavora stated that he was unsure how that was pertinent to the liquor license. **Mayor Matherly** asked Council Members to stay on topic. **Ms. Kun** asked about theft procedures at the location. Mr. Gavora stated they try to stop theft unless it may cause harm to employees and that chronic inebriates are chronic thieves. He stated they try to prevent risk to employees as much as possible.

Hearing no more Council Member questions for Mr. Gavora, **Mayor Matherly** stated it was time for Council discussion.

**Mr. Pruhs** stated he has been told that the problem is not Thrifty Liquors – it is “First Housing”. He stated the subdivision has deteriorated because of the facility. He commented that Mr. Gavora should not be crucified because of that.

**Mr. Cleworth** corrected Mr. Pruhs; he stated that it is called “Housing First”. He stated that the problems near Stacia Street were there long before Housing First. He stated that area was a big problem area when he was Mayor. He stated that he agrees with Ms. Therrien that there are folks loitering outside the liquor store before it opens early in the morning, and he knows the individuals

by name because he has to deal with them at his business downtown. **Mr. Cleworth** stated he was asked recently by Borough officials if the Council would protest the Thrifty Liquors license; he stated the Borough is having problems at the transit station. He stated there is no legal tool to deal with the chronic inebriate issue, and he does not expect police to deal with those issues all the time. He acknowledged the bigger community problem. He spoke to his own experiences in dealing with the alcohol problem at his downtown business, and he stated he is tired of it.

**Ms. Therrien** disagreed with Mr. Pruhs' statement that the Council was crucifying Mr. Gavora; she stated they were only asking questions. She pointed out that the Council postponed the issue from the last meeting to give Mr. Gavora the courtesy of being able to speak about the license. She stated she is unsure what to do about the problem, and she suggested that perhaps the City should buy out some liquor licenses.

**Mayor Matherly** stated that it was not the intent to insult Mr. Gavora; he stated that the Council wanted to have more information before acting. He stated it is the Council's right to ask questions.

**Mr. Gibson** stated he did not want a repeat of the situation that occurred with The Spur's liquor license, so that is why he supported postponing the item.

**Ms. Therrien** stated the Council postponed the issue also because they wanted more information on police calls. **Mayor Matherly** asked FECC Manager Kristi Merideth for a staff report.

Ms. Merideth stated that there were 169 calls to Thrifty Liquors from January 1 – December 31, 2019. She explained that the calls include incidents near the store. She explained the process by which FECC stacks call location.

Clerk Snider was asked to call the roll on the motion. She clarified that the motion was on the floor from the last Council Meeting, but no details were provided in the motion to protest. She asked the maker of the motion if they wished to provide additional information.

**Ms. Kun** indicated that it would be great if Thrifty Liquors could post someone at the door to help with theft problems.

**Mr. Pruhs** moved to AMEND the motion to PROTEST by changing it to a motion to WAIVE PROTEST.

Clerk Snider stated that if the motion to protest fails, the Council essentially waives protest.

**Ms. Kun** stated she would like to stipulate that the Council protests until a theft safety plan is implemented. She stated she is not sure that the Council could do that.

**Mayor Matherly** stated he is not sure how the Council could quantify such a stipulation.

**Ms. Kun**, with the concurrence of the second, moved to WITHDRAW the motion to protest.

**Mr. Pruhs**, seconded by **Ms. Rogers**, moved to WAIVE PROTEST on the Thrifty Liquors Liquor License Application for Renewal.

**Mr. Cleworth** stated that he recalls that the Council has placed restrictions and stipulations on liquor licenses in the past. He asked Attorney Ewers whether the Council has the authority to do that. Attorney Ewers stated that the Council may place conditions on the waiver of a protest.

A ROLL CALL VOTE WAS TAKEN ON THE MOTION TO WAIVE PROTEST ON THE THRIFTY LIQUORS LIQUOR LICENSE APPLICATION FOR RENEWAL AS FOLLOWS:

YEAS: Pruhs, Rogers  
NAYS: Cleworth, Kun, Gibson, Therrien  
**Mayor Matherly** declared the MOTION FAILED.

**Mayor Matherly** asked Clerk Snider what a failed motion to waive protest means. Clerk Snider stated that the failed motion to waive protest means that the Council protests the license renewal.

**Mr. Pruhs** stated he hopes everyone realizes what just happened.

Clerk Snider asked Attorney Ewers to confirm the effect of the failed motion to waive protest. Attorney Ewers confirmed that the failed motion to waive protest means that the Council protests.

**Mayor Matherly** asked Attorney Ewers whether the ABC Board makes the ultimate decision on the license renewal. Attorney Ewers explained that the ABC Board is the authority on liquor license renewals, but they are to give weight to the Council's protest.

**Ms. Therrien** suggested that some findings be included with the protest; she stated that one of the findings should be the number of incidents and ESP calls to the location.

Attorney Ewers stated it would be helpful to the Clerk in forwarding the protest if reasons were provided for the protest. He stated the Council would need to agree on findings.

**Mr. Cleworth** stated that there were a number of comments made during deliberations. He stated that, normally, the City Attorney would take all the comments to create findings of fact.

Attorney Ewers explained that when findings are needed, the Attorney prepares them and brings them back to the Council at the next meeting for approval. He stated that he could do that in this case, but, depending on the deadline for the City's response on the liquor license renewal, the protest may need to be sent to the state before findings are approved. Clerk Snider stated that the 60-day deadline is before the next Regular City Council Meeting. Attorney Ewers stated the response could go forward before the findings.

Attorney Ewers was directed to prepare findings of fact based on the Council's discussion to be presented for approval at the next meeting.

## **NEW BUSINESS**

- a) Resolution No. 4902 – A Resolution Requesting the Alaska Legislature to Fund the Recapitalization of the Community Assistance Fund. Introduced by Council Member Therrien.

PASSED and APPROVED on the CONSENT AGENDA

- b) Resolution No. 4903 – A Resolution Requesting the Borough Assembly to Reestablish the City Council as the Board of Adjustment for Appeals Involving Property Located within the City of Fairbanks. Introduced by Mayor Matherly and All City Council Members.

PASSED and APPROVED on the CONSENT AGENDA

- c) Ordinance No. 6123 – An Ordinance to Amend Fairbanks General Code Chapter 78 by Repealing Art. XIV, Sec. 507 Bicycle Licenses and Sec. 508 Bicycle License Fee. Introduced by Council Member Kun.

ADVANCED on the CONSENT AGENDA.

### **DISCUSSION ITEMS**

- a) Committee Reports

Explore Fairbanks – **Ms. Kun** shared that the new Board of Directors just took effect.

Polaris Work Group – **Mr. Pruhs** stated he was not in attendance at the last Work Group meeting. He stated that the group has discussed many options for future property development and that the City currently owns the property. He stated there is a great need in the community for senior housing. He spoke to the many different ideas that are on the table and clarified that none of them have been approved or are being funded by the City.

### **WRITTEN COMMUNICATIONS TO COUNCIL**

- a) Permanent Fund Review Board Meeting Minutes of October 30, 2019

ACCEPTED on the CONSENT AGENDA.

### **COUNCIL MEMBERS' COMMENTS**

**Mr. Gibson** stated the Fairbanks Children's Museum is a wonderful facility. He spoke to the recent retirement of Dr. Bergeson, a well-respected pediatrician in Fairbanks. **Mr. Gibson** commented on the amount of time Chief Reeder spent researching the call reports for liquor establishments and questioned whether the reports were doing more harm than good. He stated he is new to the Council and does not know how the reports came about, but perhaps the Council should reconsider the need for the reports. He suggested that the Chief's time may be better spent elsewhere. **Mr. Gibson** suggested that putting that kind of information on the record could be hurting a business since all of the calls may not have relevance to the business.

**Mr. Cleworth** asked whether staff could find a better way to prepare reports so that the Council has more clear and concise information. He thanked Attorney Ewers for taking the initiative to clarify the City's appointment of a representative to the Golden Heart Parking Service (GHPS)



Board; he stated he wished that information had been codified. He stated there is work being done to make the City Code match the agreements with the Parking Authority. **Mr. Cleworth** stated that he will bring Resolution No. 4903 to the Borough Assembly as he is the City representative for the next meeting. He expressed disappointment that the Borough does not allow the City to serve as the Board of Adjustment on appeals involving property within the City of Fairbanks. He thanked Public Works Director Jeff Jacobson for the restoration work he is doing in the downstairs hallway.

**Mr. Pruhs** stated he would like GHPS to provide the Council with a policy manual for the violations they have the authority to cite. He stated it is time for the City Council to look into the role it has in GHPS operations.

**Ms. Therrien** stated she is happy the Council has held its first goal-setting meeting. She encouraged the Council to schedule a second session so they stay on track.

Mr. Meeks asked when the Council would like to hold another session and what topics they would like to discuss. **Ms. Therrien** stated they need to continue with the earlier discussion.

**Mayor Matherly** stated a Work Session before the next Regular Council meeting was available.

**Ms. Rogers** asked Mr. Cleworth if he would like for her to attend the next Borough Assembly meeting with him; Mr. Cleworth stated that would be nice.

**Ms. Kun** thanked everyone for contributing to the difficult conversations about alcohol and the community. She gave a land acknowledgement and encouraged people who are struggling to reach out and ask for help.

**Ms. Therrien**, seconded by **Mr. Gibson**, moved to ENTER Executive Session for the purpose of discussing AFL-CIO, FFU, and IBEW Labor Negotiation Strategies.

**Mayor Matherly** called for objection and, hearing none, so ORDERED.

**Mayor Matherly** called for a brief recess. The Council reconvened in Executive Session following the brief recess.

### **EXECUTIVE SESSION**

- a) AFL-CIO Labor Negotiation Strategy
- b) FFU Labor Negotiation Strategy
- c) IBEW Labor Negotiation Strategy

The City Council met in Executive Session to discuss AFL-CIO, FFU, and IBEW Labor Negotiation Strategies. Direction was given to the negotiating teams, and no action was taken.

**ADJOURNMENT**

**Ms. Kun**, seconded by **Mr. Gibson**, moved to ADJOURN the meeting.

**Mayor Matherly** called for objection and, hearing none, so ORDERED.

**Mayor Matherly** declared the meeting adjourned at 11:00 p.m.

---

JIM MATHERLY, MAYOR

ATTEST:

---

D. DANYIELLE SNIDER, CMC, CITY CLERK

Transcribed by: EB



**FAIRBANKS CITY COUNCIL  
SPECIAL MEETING MINUTES, FEBRUARY 14, 2020  
FAIRBANKS CITY COUNCIL CHAMBERS  
800 CUSHMAN STREET, FAIRBANKS, ALASKA**

The City Council convened at 5:15 p.m. on the above date to conduct a Special Meeting of the Fairbanks City Council at the City Council Chambers, 800 Cushman Street, Fairbanks, Alaska, with Mayor Jim Matherly presiding and with the following Council Members in attendance:

Council Members Present: Shoshana Kun, Seat A (arrived at 5:27 p.m.)  
June Rogers, Seat B  
Valerie Therrien, Seat C  
Aaron Gibson, Seat D  
Jerry Cleworth, Seat E  
David Pruhs, Seat F

Absent: None

Also Present: Paul Ewers, City Attorney  
D. Danyielle Snider, City Clerk  
Jeff Jacobson, Public Works Director  
Mike Meeks, Chief of Staff  
Kristi Merideth, FECC Manager  
Angela Foster-Snow, HR Director  
Jim Styers, Fire Chief

**SPECIAL ORDERS**

- a) Request for Reconsideration by Council Member Gibson of the Motion to Waive Protest on the Renewal of the Thrifty Liquors Liquor License from the Regular Meeting of February 10, 2020. The written request to reconsider was filed on February 11, 2020.

| Lic. # | DBA             | License Type  | Licensee            | Premises Address    |
|--------|-----------------|---------------|---------------------|---------------------|
| 1134   | Thrifty Liquors | Package Store | Market Basket, Inc. | 1410 Cushman Street |

She explained the procedure for reconsideration and what would occur if a motion to reconsider either passed or failed.

**Mr. Gibson**, seconded by **Mr. Pruhs**, moved to RECONSIDER the motion to waive protest of the Thrifty Liquors liquor license from the Regular Meeting of February 10, 2020.

**Mr. Gibson** explained that he filed the request to reconsider because he felt that the Council limited the owner’s testimony, and he felt that the Council did not provide a clear reason for protesting the renewal of the license.

**A ROLL CALL VOTE ON THE MOTION TO RECONSIDER THRIFTY LIQUOR APPLICATION FOR LIQUOR LICENSE RENEWAL AS FOLLOWS:**

YEAS: Pruhs, Rogers, Gibson  
NAYS: Cleworth, Therrien  
ABSENT: Kun

**Mayor Matherly** declared the MOTION CARRIED.

**Mayor Matherly** stated that the motion to waive protest has returned to the floor.

*The motion to waive protest on the Liquor License Application for Renewal was made by Mr. Pruhs, seconded by Ms. Rogers, at the Regular Meeting of February 10, 2020.*

**Mr. Pruhs** mentioned the communication the Council received from Mr. Gavora's attorney, Mike Kramer. He stated the Council should allow Mr. Gavora to speak.

**Mayor Matherly** asked the Council whether any member objected to allowing the owner of Thrifty Liquors to speak. No members objected.

Mr. Gavora requested that the Thrifty Liquors store manager be allowed to speak. **Mayor Matherly** asked the Council whether any member objected to allowing the store manager of Thrifty Liquors to speak. No members objected

Susan Hamner, 1640 Willow Street, Fairbanks – Ms. Hamner stated she works at the store Monday through Friday, and she feels that the store has run better since she began managing it over a year ago. She stated that employees go above and beyond what is required by law, and they do 100% ID check on customers.

**Mr. Pruhs** stated the information the Council received shows that, over the last 30 days, the highest liquor sales at the location between the hours of 8 and 9 a.m. was \$43. He asked whether there are people waiting outside the store at 8 a.m. to purchase liquor. Ms. Hamner stated that she does not believe that to be the case. She stated there are grocery and cigarette sales in the morning, and sometimes night workers getting off work come in the morning to purchase liquor. **Mr. Pruhs** stated he visited the store earlier that morning, and he noted that about 45% of the floor space was dedicated to non-alcoholic items. He asked whether most morning sales were for liquor products. Ms. Hamner stated that most morning sales are for grocery items. **Mr. Pruhs** stated that Thrifty Liquors is in a dangerous neighborhood; Ms. Hamner disagreed. She stated that there are a lot of mentally challenged people in the area, and when employees see someone passed out on the street, they call the authorities.

**Ms. Therrien** asked who does security checks in and around the building. Ms. Hamner stated she and her employees check around the building to make sure no one is loitering and to make sure none of their customers feel threatened or bothered. **Ms. Therrien** asked Ms. Hamner whether she considers the congregating of four or five people in the parking loitering. Ms. Hamner stated that sometimes it is loitering, but sometimes it is a meeting spot. **Ms. Therrien** asked Ms. Hamner whether she ever witnesses people drinking in the parking lot. Ms. Hamner stated she sees that occasionally, but when that happens, they are told to leave the property. **Ms. Therrien** how often that occurs; Ms. Hamner stated it does not happen often and that she has only had to call the police twice within the past 30 days.

**Mayor Matherly** asked Ms. Hamner how long she has worked at Thrifty Liquors. Ms. Hamner stated she has worked for the Gavoras for six years and at Thrifty Liquors for over a year.

**Ms. Therrien** asked Ms. Hamner how often employees have to turn away intoxicated people from the store. Ms. Hamner stated that occurs about every other day, and it is often the same individuals.

**Mr. Gibson** asked whether Thrifty Liquors has ever been cited by the State; Ms. Hamner replied that to her knowledge it has not. **Mr. Gibson** asked Ms. Hamner whether she has ever been cited for selling to someone who is legally not allowed to purchase alcohol. Ms. Hamner replied that she has not.

**Mr. Pruhs** asked Ms. Hamner about her history in working for the Gavoras. Ms. Hamner stated she began working in 2014 at Gavoras on Third Street. She stated she was moved to Gavora's Liquor and Fine Wine at the Shopper's Forum, then she was promoted to manager. She stated that shortly before that store closed, she was asked to manage Thrifty Liquors.

**Mayor Matherly** asked how long Thrifty Liquors had been on located at the corner of Airport Way. Mr. Gavora stated it opened around 1984 for the Gavoras, but it has probably been there since the early 1970s.

**Ms. Rogers** thanked Thrifty Liquors representatives for coming and for giving an overview. She stated it is a community issue, and there is a community responsibility to uplift businesses that are trying to work under difficult circumstances. She stated she will support the license renewal.

**Mr. Pruhs** stated that in the Findings of Fact, there is no mention that there were no members of the public who testified against the Thrifty Liquors license. He stated the Council protested a liquor license one time when there was a shooting at the Greyhound Lounge.

A ROLL CALL VOTE WAS TAKEN ON THE MOTION TO WAIVE PROTEST ON THE THRIFTY LIQUORS LIQUOR LICENSE APPLICATION FOR RENEWAL AS FOLLOWS:

YEAS: Pruhs, Gibson, Rogers, Matherly

NAYS: Therrien, Kun, Cleworth

**Mayor Matherly** declared the MOTION CARRIED.

b) [If required] Review and Approval of Findings (reason for protest)

Clerk Snider stated that Item (b) would not be addressed because the motion to waive protest passed.

**Mr. Pruhs**, seconded by **Ms. Therrien**, moved to ENTER Executive Session for the purpose of discussing AFL-CIO, FFU, and IBEW Labor Negotiations Strategies.

**Mayor Matherly** called for objection and, hearing none, so ORDERED.

**Mayor Matherly** called for a brief recess. The Council reconvened in Executive Session following the brief recess.

**EXECUTIVE SESSION**

- a) AFL-CIO Labor Negotiation Strategy
- b) FFU Labor Negotiation Strategy
- c) IBEW Labor Negotiation Strategy

The City Council met in Executive Session to discuss AFL-CIO, FFU, and IBEW Labor Negotiations Strategies. Direction was given to the negotiating teams, and no action was taken.

**ADJOURNMENT**

**Mr. Pruhs**, seconded by **Ms. Therrien**, moved to ADJOURN the meeting.

**Mayor Matherly** called for objection and, hearing none, so ORDERED.

**Mayor Matherly** declared the meeting adjourned at 6:54 p.m.

---

JIM MATHERLY, MAYOR

ATTEST:

---

D. DANYIELLE SNIDER, CMC, CITY CLERK

Transcribed by: EB



# City of Fairbanks

Office of the City Clerk

800 Cushman Street

Fairbanks, AK 99701

(907)459-6715

Fax (907)459-6710

## MEMORANDUM

TO: Mayor Jim Matherly and City Council Members

FROM: D. Danyielle Snider, CMC, City Clerk 

SUBJECT: Liquor License Renewals

DATE: April 7, 2020

Notice has been received from the State Alcohol & Marijuana Control Office (AMCO) for the following liquor license renewals:

| Lic. # | DBA                                | License Type                       | Licensee                                     | Address                     |
|--------|------------------------------------|------------------------------------|--|-----------------------------|
| 4816   | Mayan Palace                       | Beverage Dispensary                | Taco Azteca, Inc.                            | 3401 Airport Way            |
| 3151   | Fred Meyer 485                     | Package Store                      | Fred Meyer Stores, Inc.                      | 3755 Airport Way            |
| 1059   | Raven Landing Center               | Beverage Dispensary                | Retirement Community of Fairbanks            | 949 McGown Street           |
| 54     | American Legion Post 11            | Club                               | The American Legion, Dorman H Baker Post #11 | 129 1st Avenue              |
| 5436   | Hoarfrost Distilling               | Distillery                         | Hoarfrost Distilling, LLC                    | 3501 Lathrop Street, Unit F |
| 3170   | The Odom Corporation               | Wholesale – General                | The Odom Corporation                         | 3401 Peger Road, Bay 1      |
| 4831   | Irashai Japanese Restaurant        | Restaurant/Eating Place            | 2GIRO, Inc.                                  | 419 Merhar Avenue, Suite B  |
| 4156   | Holiday #622                       | Package Store                      | Holiday Alaska, LLC                          | 2300 S. Cushman Street      |
| 1639   | Alaska Salmon Bake                 | Restaurant/Eating Place – Seasonal | Malemute, Inc.                               | 2300 Airport Way            |
| 4720   | Gallantino’s Italian Restaurant    | Beverage Dispensary                | Gallantino’s, Inc.                           | 1446 S. Cushman Street      |
| 4174   | Big Daddy’s Bar-B-Q & Banquet Hall | Beverage Dispensary                | RTG, LLC                                     | 107 Wickersham Street       |
| 5500   | K & L Distributors Alaska          | Wholesale – Malt Beverage & Wine   | White Mountain Beverage, LLC                 | 945 Elizabeth Street        |

Pursuant to FGC Sec. 14-178 the Council must determine whether to protest liquor license renewal applications after holding a public hearing.

Per the Council’s request, the Police Department has included a call report for the locations listed.

The Finance Department is recommending protest of license #4174 (Big Daddy’s Bar-B-Q), as the business does not have a 2020 City Business License. The Fire Department is recommending protest of license #4174 (Big Daddy’s Bar-B-Q) and license #54 (American Legion Post 11) for incomplete inspections. There are no other department-recommended objections to these liquor license renewals.

# CITY OF FAIRBANKS PUBLIC SAFETY

Mayan Palace 3401 Airport Way

03/19/2019 - 03/17/2020

| Report # | Call Time        | Nature             | Location         | Prime Unit | Disp. | Close Time          |
|----------|------------------|--------------------|------------------|------------|-------|---------------------|
|          | 02/23/2020 14:21 | WANTED PERSON -    | 3401 AIRPORT WAY | O29        | NRP   | 02/23/2020 15:48:27 |
|          | 02/04/2020 17:25 | TRESPASS/UNWANTE   | 3401 AIRPORT WAY | O13        | NRP   | 02/04/2020 17:49:10 |
|          | 01/21/2020 19:20 | TRESPASS/UNWANTE   | 3401 AIRPORT WAY | O2         | SUBL  | 01/21/2020 21:29:31 |
| 20000190 | 01/18/2020 00:01 | DISTURBANCE        | 3401 AIRPORT WAY | O5         | RPT   | 01/18/2020 00:47:33 |
| 19003454 | 12/25/2019 22:01 | SI - FLAG DOWN     | 3401 AIRPORT WAY | O2         | RPT   | 12/25/2019 22:07:13 |
| 19004501 | 11/27/2019 17:36 | SI - FOLLOW-UP     | 3401 AIRPORT WAY | O39        | NRP   | 11/27/2019 17:42:15 |
|          | 11/27/2019 16:57 | TRESPASS/UNWANTE   | 3401 AIRPORT WAY | O1         | NRP   | 11/27/2019 17:36:23 |
|          | 10/24/2019 13:32 | SUSPICIOUS PERSON  | 3401 AIRPORT WAY | O7         | NRP   | 10/24/2019 13:48:49 |
|          | 10/23/2019 10:47 | DAMAGE/VANDALISM   | 3401 AIRPORT WAY | O22        | NRP   | 10/23/2019 11:16:56 |
| 19003648 | 09/20/2019 09:14 | PAST THEFT - BRAVO | 3401 AIRPORT WAY | DESK       | RPT   | 09/20/2019 10:09:13 |
|          | 09/09/2019 19:05 | ALARM BURGLARY -   | 3401 AIRPORT WAY | O54        | NRP   | 09/09/2019 19:41:33 |
|          | 08/15/2019 07:48 | TRESPASS/UNWANTE   | 3401 AIRPORT WAY | O1         | NRP   | 08/15/2019 08:07:26 |
|          | 07/29/2019 07:57 | TRESPASS/UNWANTE   | 3401 AIRPORT WAY | O3         | NRP   | 07/29/2019 08:18:54 |
|          | 04/09/2019 14:50 | DISTURBANCE -      | 3401 AIRPORT WAY | L7         | NRP   | 04/09/2019 15:38:54 |
|          | 04/02/2019 23:57 | SUSP               | 3401 AIRPORT WAY | S9         | NRP   | 04/03/2019 01:29:08 |

Total Number of Events Listed: 15



# CITY OF FAIRBANKS PUBLIC SAFETY

**Fred Meyer #485 3755 Airport Way**

03/19/2019 - 03/17/2020

| Report # | Call Time        | Nature              | Location         | Prime Unit | Disp. | Close Time          |
|----------|------------------|---------------------|------------------|------------|-------|---------------------|
| 20000886 | 03/15/2020 15:05 | THEFT FROM          | 3755 AIRPORT WAY | O53        | RPT   | 03/15/2020 16:18:29 |
|          | 03/14/2020 16:37 | HITRUN - NO/MINOR   | 3755 AIRPORT WAY | O54        | NRP   | 03/14/2020 17:16:50 |
| 20000854 | 03/14/2020 14:08 | SUPP-               | 3755 AIRPORT WAY | O50        | RPT   | 03/14/2020 19:31:24 |
| 20000855 | 03/13/2020 18:00 | PAST VEHICLE THEFT  | 3755 AIRPORT WAY | O50        | RPT   | 03/13/2020 19:59:40 |
| 20000854 | 03/13/2020 15:47 | PAST HIT & RUN -    | 3755 AIRPORT WAY | DESK       | RPT   | 03/13/2020 22:01:36 |
|          | 03/13/2020 12:47 | PAST HIT & RUN -    | 3755 AIRPORT WAY | O15        | NRP   | 03/13/2020 13:44:09 |
| 20000837 | 03/12/2020 19:13 | THEFT - DELTA       | 3755 AIRPORT WAY | O54        | RPT   | 03/12/2020 20:02:44 |
|          | 03/12/2020 16:50 | TRESPASS/UNWANTE    | 3755 AIRPORT WAY | O9         | NRP   | 03/12/2020 17:06:52 |
|          | 03/10/2020 20:44 | MISSING PERSON AT   | 3755 AIRPORT WAY | O4         | NRP   | 03/10/2020 23:06:09 |
|          | 03/09/2020 18:57 | SI - FOLLOW-UP      | 3755 AIRPORT WAY | O26        | NRP   | 03/09/2020 19:33:56 |
| 20000801 | 03/09/2020 18:11 | THEFT - OVERRIDE -  | 3755 AIRPORT WAY | O26        | RPT   | 03/09/2020 18:25:12 |
|          | 03/07/2020 07:13 | AOA - NON URGENT -  | 3755 AIRPORT WAY | O39        | NRP   | 03/07/2020 07:23:18 |
|          | 03/04/2020 18:10 | TRESPASS/UNWANTE    | 3755 AIRPORT WAY | O9         | NRP   | 03/04/2020 18:24:48 |
| 20000753 | 03/04/2020 11:29 | WANTED PERSON -     | 3755 AIRPORT WAY | O9         | RPT   | 03/04/2020 12:15:20 |
|          | 03/04/2020 09:15 | PAST HIT & RUN -    | 3755 AIRPORT WAY | O22        | NRP   | 03/04/2020 10:10:54 |
| 20000655 | 03/01/2020 19:34 | SUPPLEMENTAL-       | 3755 AIRPORT WAY | O13        | RPT   | 03/01/2020 21:40:27 |
| 20000698 | 02/28/2020 23:15 | TRESPASS/UNWANTE    | 3755 AIRPORT WAY | O52        | RPT   | 02/29/2020 00:33:33 |
|          | 02/27/2020 20:59 | TRESPASS/UNWANTE    | 3755 AIRPORT WAY | S5         | NRP   | 02/27/2020 21:25:43 |
|          | 02/27/2020 18:26 | TRESPASS/UNWANTE    | 3755 AIRPORT WAY | L3         | NRP   | 02/27/2020 19:11:50 |
| 20000656 | 02/25/2020 12:25 | ATTEMPTED VEHICLE   | 3755 AIRPORT WAY | S3         | RPT   | 02/25/2020 14:40:05 |
| 20000640 | 02/23/2020 19:32 | WANTED PERSON -     | 3755 AIRPORT WAY | O13        | RPT   | 02/23/2020 20:21:47 |
| 20000621 | 02/22/2020 17:08 | TRESPASS/UNWANTE    | 3755 AIRPORT WAY | O13        | RPT   | 02/22/2020 18:02:49 |
|          | 02/22/2020 14:29 | TRESPASS/UNWANTE    | 3755 AIRPORT WAY | O9         | NRP   | 02/22/2020 14:43:55 |
|          | 02/22/2020 11:04 | PAST MVC - ALPHA    | 3755 AIRPORT WAY | DESK       | NRP   | 02/22/2020 11:14:30 |
|          | 02/22/2020 10:51 | DISTURBANCE         | 3755 AIRPORT WAY | O7         | NRP   | 02/22/2020 11:29:05 |
|          | 02/21/2020 18:19 | TRESPASS/UNWANTE    | 3755 AIRPORT WAY | O29        | NRP   | 02/21/2020 19:18:14 |
|          | 02/21/2020 17:24 | TRESPASS/UNWANTE    | 3755 AIRPORT WAY | O54        | NRP   | 02/21/2020 18:01:48 |
|          | 02/20/2020 18:43 | SI - FLAG DOWN      | 3755 AIRPORT WAY | O29        | NRP   | 02/20/2020 18:47:44 |
|          | 02/20/2020 08:22 | SI - SECURITY CHECK | 3755 AIRPORT WAY | O9         | NRP   | 02/20/2020 08:30:23 |
|          | 02/19/2020 21:41 | THREAT SUSP NOT     | 3755 AIRPORT WAY | O5         | NRP   | 02/19/2020 22:49:23 |
|          | 02/19/2020 20:12 | TRESPASS/UNWANTE    | 3755 AIRPORT WAY | O4         | NRP   | 02/19/2020 22:09:54 |
| 20000577 | 02/19/2020 15:05 | TRESPASS/UNWANTE    | 3755 AIRPORT WAY | O54        | RPT   | 02/19/2020 15:41:03 |
|          | 02/18/2020 16:19 | SUSP                | 3755 AIRPORT WAY | S1         | NRP   | 02/18/2020 16:37:30 |
| 20000543 | 02/17/2020 12:25 | FRAUD/FORGERY       | 3755 AIRPORT WAY | DESK       | RPT   | 02/17/2020 12:33:54 |
| 20000537 | 02/16/2020 23:03 | SUSPICIOUS PERSON   | 3755 AIRPORT WAY | O4         | RPT   | 02/16/2020 23:28:21 |
| 20000512 | 02/14/2020 16:49 | TRESPASS/UNWANTE    | 3755 AIRPORT WAY | O29        | RPT   | 02/14/2020 17:47:10 |
|          | 02/14/2020 13:14 | OFFICER ADVICE      | 3755 AIRPORT WAY | O53        | NRP   | 02/14/2020 16:34:50 |
| 20000502 | 02/13/2020 21:34 | TRESPASS/UNWANTE    | 3755 AIRPORT WAY | O17        | RPT   | 02/13/2020 22:47:50 |
|          | 02/13/2020 14:55 | OFFICER ADVICE      | 3755 AIRPORT WAY | O29        | NRP   | 02/13/2020 16:14:52 |
|          | 02/12/2020 19:26 | TRESPASS/UNWANTE    | 3755 AIRPORT WAY | L3         | NRP   | 02/12/2020 19:59:40 |
| 20000487 | 02/12/2020 11:59 | TRESPASS/UNWANTE    | 3755 AIRPORT WAY | O3         | RPT   | 02/12/2020 13:42:38 |

Report Generated: 03/17/2020 14:09:30 | User ID: 1225

| Report # | Call Time        | Nature              | Location         | Prime Unit | Disp. | Close Time          |
|----------|------------------|---------------------|------------------|------------|-------|---------------------|
|          | 02/11/2020 16:36 | TRESPASS/UNWANTE    | 3755 AIRPORT WAY | O13        | NRP   | 02/11/2020 16:57:54 |
|          | 02/10/2020 09:39 | URGENT WELFARE      | 3755 AIRPORT WAY | O22        | NRP   | 02/10/2020 10:02:32 |
|          | 02/09/2020 18:28 | DISTURBANCE         | 3755 AIRPORT WAY | O13        | NRP   | 02/09/2020 18:52:26 |
|          | 02/09/2020 17:56 | TRESPASS/UNWANTE    | 3755 AIRPORT WAY | S1         | NRP   | 02/09/2020 18:15:54 |
| 20000443 | 02/09/2020 16:48 | TRESPASS/UNWANTE    | 3755 AIRPORT WAY | O29        | RPT   | 02/09/2020 17:59:48 |
| 20000436 | 02/08/2020 17:09 | THEFT - DELTA       | 3755 AIRPORT WAY | O13        | RPT   | 02/08/2020 18:00:04 |
| 20000388 | 02/04/2020 21:04 | TRESPASS/UNWANTE    | 3755 AIRPORT WAY | O2         | RPT   | 02/04/2020 22:14:57 |
|          | 02/04/2020 17:39 | TRESPASS/UNWANTE    | 3755 AIRPORT WAY | O13        | NRP   | 02/04/2020 17:55:32 |
|          | 02/04/2020 14:35 | PAST MVC - ALPHA    | 3755 AIRPORT WAY | DESK       | NRP   | 02/04/2020 14:56:52 |
|          | 02/04/2020 14:27 | MVC - NO INJURIES - | 3755 AIRPORT WAY | O22        | NRP   | 02/04/2020 15:47:26 |
| 20000382 | 02/03/2020 18:58 | TRESPASS/UNWANTE    | 3755 AIRPORT WAY | O13        | RPT   | 02/03/2020 20:14:07 |
|          | 02/03/2020 17:28 | TRESPASS/UNWANTE    | 3755 AIRPORT WAY | S1         | NRP   | 02/03/2020 17:49:40 |
|          | 02/03/2020 15:58 | PAST HIT & RUN -    | 3755 AIRPORT WAY | DESK       | NRP   | 02/03/2020 17:36:26 |
|          | 02/02/2020 20:48 | TRESPASS/UNWANTE    | 3755 AIRPORT WAY | S1         | NRP   | 02/02/2020 21:24:02 |
| 20000364 | 02/02/2020 08:12 | PAST THEFT - BRAVO  | 3755 AIRPORT WAY | O39        | RPT   | 02/02/2020 09:12:29 |
| 20000348 | 02/01/2020 12:58 | TRESPASS/UNWANTE    | 3755 AIRPORT WAY | O9         | RPT   | 02/01/2020 14:21:36 |
|          | 01/31/2020 20:05 | TRESPASS/UNWANTE    | 3755 AIRPORT WAY | L3         | NRP   | 01/31/2020 21:07:18 |
|          | 01/30/2020 19:51 | DISTURBANCE         | 3755 AIRPORT WAY | L3         | NRP   | 01/30/2020 20:09:09 |
|          | 01/29/2020 11:06 | SUSPICIOUS PERSON   | 3755 AIRPORT WAY | O53        | NRP   | 01/29/2020 12:41:13 |
|          | 01/29/2020 10:39 | PAST HIT & RUN -    | 3755 AIRPORT WAY | DESK       | NRP   | 01/29/2020 10:44:26 |
|          | 01/25/2020 18:19 | TRESPASS/UNWANTE    | 3755 AIRPORT WAY | O52        | NRP   | 01/25/2020 18:34:09 |
| 20000273 | 01/24/2020 19:45 | AOA - NON URGENT -  | 3755 AIRPORT WAY | O54        | RPT   | 01/24/2020 20:33:06 |
| 20000269 | 01/24/2020 12:10 | LOST PROPERTY -     | 3755 AIRPORT WAY | DESK       | RPT   | 01/24/2020 15:02:16 |
| 20000263 | 01/23/2020 21:40 | PAST THEFT - BRAVO  | 3755 AIRPORT WAY | O19        | RPT   | 01/23/2020 22:43:40 |
|          | 01/23/2020 15:06 | TRESPASS/UNWANTE    | 3755 AIRPORT WAY | O53        | NRP   | 01/23/2020 15:37:52 |
|          | 01/23/2020 13:06 | PAST MVC - ALPHA    | 3755 AIRPORT WAY | DESK       | NRP   | 01/23/2020 13:54:20 |
| 20000257 | 01/22/2020 16:41 | FOUND PROPERTY -    | 3755 AIRPORT WAY | O7         | RPT   | 01/23/2020 10:50:50 |
|          | 01/22/2020 15:30 | TRESPASS/UNWANTE    | 3755 AIRPORT WAY | O54        | NRP   | 01/22/2020 16:04:47 |
|          | 01/21/2020 08:46 | FOUND PROPERTY -    | 3755 AIRPORT WAY | DESK       | NRP   | 01/21/2020 16:18:30 |
| 20000187 | 01/19/2020 15:57 | SI - FOLLOW-UP      | 3755 AIRPORT WAY | O39        | RPT   | 01/19/2020 16:08:37 |
| 20000206 | 01/19/2020 14:51 | TRESPASS/UNWANTE    | 3755 AIRPORT WAY | O7         | RPT   | 01/19/2020 16:52:19 |
| 20000200 | 01/18/2020 21:38 | THREATENING         | 3755 AIRPORT WAY | O19        | RPT   | 01/18/2020 23:29:05 |
| 20000198 | 01/18/2020 19:58 | DISTURBANCE         | 3755 AIRPORT WAY | O53        | RPT   | 01/18/2020 20:33:28 |
|          | 01/18/2020 16:56 | TRESPASS/UNWANTE    | 3755 AIRPORT WAY | O52        | NRP   | 01/18/2020 17:07:49 |
|          | 01/16/2020 19:47 | TRESPASS/UNWANTE    | 3755 AIRPORT WAY | O53        | NRP   | 01/16/2020 20:06:44 |
|          | 01/15/2020 10:27 | URGENT WELFARE      | 3755 AIRPORT WAY | S6         | NRP   | 01/15/2020 11:13:10 |
| 20000146 | 01/14/2020 18:03 | TRESPASS/UNWANTE    | 3755 AIRPORT WAY | O52        | RPT   | 01/14/2020 19:10:13 |
|          | 01/14/2020 15:26 | PAST HIT & RUN -    | 3755 AIRPORT WAY | O3         | NRP   | 01/14/2020 16:28:20 |
|          | 01/14/2020 00:57 | DAMAGE/VANDALISM    | 3755 AIRPORT WAY | DESK       | NRP   | 01/14/2020 01:03:57 |
|          | 01/12/2020 22:36 | THREAT - BRAVO      | 3755 AIRPORT WAY | O2         | NRP   | 01/12/2020 23:13:25 |
|          | 01/11/2020 17:20 | TRESPASS/UNWANTE    | 3755 AIRPORT WAY | O54        | NRP   | 01/11/2020 17:35:26 |
| 20000115 | 01/11/2020 15:27 | WANTED PERSON -     | 3755 AIRPORT WAY | O13        | RPT   | 01/11/2020 16:30:48 |
| 20000116 | 01/11/2020 15:27 | TRESPASS/UNWANTE    | 3755 AIRPORT WAY | O52        | RPT   | 01/11/2020 16:14:12 |
| 20000100 | 01/10/2020 14:02 | THEFT FROM          | 3755 AIRPORT WAY | O15        | RPT   | 01/10/2020 14:30:11 |
|          | 01/07/2020 13:09 | VERBAL DOMESTIC     | 3755 AIRPORT WAY | O3         | NRP   | 01/07/2020 13:36:22 |

| Report # | Call Time        | Nature              | Location         | Prime Unit | Disp. | Close Time          |
|----------|------------------|---------------------|------------------|------------|-------|---------------------|
| 20000056 | 01/05/2020 17:39 | ASSAULT - DELTA     | 3755 AIRPORT WAY | S5         | RPT   | 01/05/2020 20:07:14 |
|          | 01/04/2020 14:11 | 10-36               | 3755 AIRPORT WAY | O53        | WAR   | 01/04/2020 14:22:33 |
| 20000031 | 01/03/2020 15:25 | INCAPACITATED       | 3755 AIRPORT WAY | O54        | RPT   | 01/03/2020 16:19:06 |
| 20000032 | 01/03/2020 15:21 | PAST HIT & RUN -    | 3755 AIRPORT WAY | DESK       | RPT   | 01/03/2020 16:39:51 |
| 20000029 | 01/03/2020 15:03 | TRESPASS/UNWANTE    | 3755 AIRPORT WAY | O53        | RPT   | 01/03/2020 16:53:47 |
| 20000023 | 01/02/2020 20:49 | LOST PROPERTY -     | 3755 AIRPORT WAY | O15        | RPT   | 01/03/2020 07:41:42 |
|          | 12/28/2019 10:26 | PAST HIT & RUN -    | 3755 AIRPORT WAY | DESK       | NRP   | 12/28/2019 10:32:43 |
| 19004855 | 12/27/2019 21:49 | PHYSICAL DOMESTIC   | 3755 AIRPORT WAY | O53        | RPT   | 12/27/2019 22:56:28 |
| 19004853 | 12/27/2019 19:28 | VEHICLE THEFT -     | 3755 AIRPORT WAY | O39        | RPT   | 12/27/2019 20:48:36 |
| 19004821 | 12/24/2019 19:37 | FOUND PROPERTY -    | 3755 AIRPORT WAY | O52        | RPT   | 12/24/2019 22:56:29 |
|          | 12/24/2019 11:22 | TRESPASS/UNWANTE    | 3755 AIRPORT WAY | O22        | NRP   | 12/24/2019 11:54:25 |
| 19004807 | 12/23/2019 13:33 | PAST THEFT - BRAVO  | 3755 AIRPORT WAY | O15        | RPT   | 12/23/2019 14:42:26 |
| 19004793 | 12/21/2019 22:44 | TRESPASS/UNWANTE    | 3755 AIRPORT WAY | O34        | RPT   | 12/22/2019 01:15:15 |
| 19004789 | 12/21/2019 18:56 | ASSAULT - DELTA     | 3755 AIRPORT WAY | O53        | RPT   | 12/21/2019 19:27:12 |
| 19004785 | 12/21/2019 16:29 | TRESPASS/UNWANTE    | 3755 AIRPORT WAY | O54        | RPT   | 12/21/2019 17:15:39 |
|          | 12/20/2019 22:01 | TRESPASS/UNWANTE    | 3755 AIRPORT WAY | O2         | SUBL  | 12/20/2019 22:18:47 |
| 19004776 | 12/20/2019 16:39 | TRESPASS/UNWANTE    | 3755 AIRPORT WAY | O52        | RPT   | 12/20/2019 18:33:14 |
| 19004752 | 12/19/2019 17:41 | TRESPASS/UNWANTE    | 3755 AIRPORT WAY | O52        | RPT   | 12/19/2019 18:23:12 |
| 19004751 | 12/19/2019 16:23 | PAST VEHICLE THEFT  | 3755 AIRPORT WAY | O52        | RPT   | 12/19/2019 17:35:14 |
|          | 12/18/2019 20:14 | TRESPASS/UNWANTE    | 3755 AIRPORT WAY | O2         | NRP   | 12/18/2019 21:50:00 |
|          | 12/17/2019 19:11 | TRESPASS/UNWANTE    | 3755 AIRPORT WAY | O53        | NRP   | 12/17/2019 19:21:52 |
| 19004727 | 12/17/2019 17:16 | WANTED PERSON -     | 3755 AIRPORT WAY | O1         | RPT   | 12/17/2019 17:48:32 |
|          | 12/15/2019 10:50 | TRESPASS/UNWANTE    | 3755 AIRPORT WAY | O7         | NRP   | 12/15/2019 11:05:37 |
|          | 12/14/2019 14:40 | TRESPASS/UNWANTE    | 3755 AIRPORT WAY | I44        | NRP   | 12/14/2019 15:53:40 |
|          | 12/12/2019 17:18 | SUSP                | 3755 AIRPORT WAY | S9         | NRP   | 12/12/2019 17:57:48 |
| 19004677 | 12/12/2019 12:08 | DRUGS - ALPHA       | 3755 AIRPORT WAY | O15        | RPT   | 12/12/2019 12:25:44 |
|          | 12/11/2019 22:35 | TRESPASS/UNWANTE    | 3755 AIRPORT WAY | O17        | NRP   | 12/11/2019 22:51:10 |
|          | 12/09/2019 18:27 | SUSP                | 3755 AIRPORT WAY | O53        | NRP   | 12/09/2019 19:25:01 |
| 19004647 | 12/08/2019 22:22 | TRESPASS/UNWANTE    | 3755 AIRPORT WAY | O34        | RPT   | 12/09/2019 01:00:01 |
| 19004644 | 12/08/2019 19:19 | TRESPASS/UNWANTE    | 3755 AIRPORT WAY | O13        | RPT   | 12/08/2019 20:05:21 |
| 19004627 | 12/07/2019 15:10 | TRESPASS/UNWANTE    | 3755 AIRPORT WAY | O29        | RPT   | 12/07/2019 18:07:58 |
|          | 12/06/2019 22:37 | TRESPASS/UNWANTE    | 3755 AIRPORT WAY | O2         | NRP   | 12/06/2019 22:58:23 |
|          | 12/06/2019 20:23 | TRESPASS/UNWANTE    | 3755 AIRPORT WAY | O39        | NRP   | 12/06/2019 22:05:07 |
|          | 12/05/2019 20:43 | TRESPASS/UNWANTE    | 3755 AIRPORT WAY | O29        | NRP   | 12/05/2019 21:01:24 |
|          | 12/04/2019 14:37 | TRESPASS/UNWANTE    | 3755 AIRPORT WAY | O3         | NRP   | 12/04/2019 15:22:33 |
| 19004578 | 12/03/2019 16:05 | TRESPASS/UNWANTE    | 3755 AIRPORT WAY | O13        | RPT   | 12/03/2019 16:34:21 |
|          | 12/02/2019 16:49 | DVPO SERVICE        | 3755 AIRPORT WAY | O1         | NRP   | 12/03/2019 17:55:29 |
|          | 12/02/2019 16:45 | MVC - NO INJURIES - | 3755 AIRPORT WAY | O13        | NRP   | 12/02/2019 17:18:44 |
|          | 12/01/2019 20:05 | URGENT WELFARE      | 3755 AIRPORT WAY | O29        | NRP   | 12/01/2019 20:49:42 |
| 19004485 | 12/01/2019 08:18 | SI - FOLLOW-UP      | 3755 AIRPORT WAY | O50        | RPT   | 12/01/2019 11:02:28 |
|          | 11/30/2019 23:19 | ALARM BURGLARY -    | 3755 AIRPORT WAY | O5         | FAB   | 11/30/2019 23:42:11 |
| 19004541 | 11/30/2019 21:39 | WANTED PERSON -     | 3755 AIRPORT WAY | O13        | RPT   | 11/30/2019 23:57:40 |
|          | 11/29/2019 11:29 | TRESPASS/UNWANTE    | 3755 AIRPORT WAY | O7         | NRP   | 11/29/2019 11:44:45 |
| 19004520 | 11/29/2019 07:02 | DUI - PARKED -      | 3755 AIRPORT WAY | O19        | RPT   | 11/29/2019 08:57:57 |
|          | 11/25/2019 23:15 | 10-36               | 3755 AIRPORT WAY | L4         | WAR   | 11/25/2019 23:18:56 |

| Report # | Call Time        | Nature               | Location         | Prime Unit | Disp. | Close Time          |
|----------|------------------|----------------------|------------------|------------|-------|---------------------|
| 19004467 | 11/24/2019 17:02 | LOST PROPERTY -      | 3755 AIRPORT WAY | I41        | RPT   | 11/24/2019 20:21:53 |
|          | 11/24/2019 15:55 | HITRUN - NO/MINOR    | 3755 AIRPORT WAY | O13        | NRP   | 11/24/2019 16:44:42 |
| 19004468 | 11/24/2019 15:26 | TRESPASS/UNWANTE     | 3755 AIRPORT WAY | O29        | RPT   | 11/24/2019 22:20:31 |
|          | 11/22/2019 22:27 | WANTED PERSON -      | 3755 AIRPORT WAY | O2         | NRP   | 11/22/2019 22:41:58 |
| 19004427 | 11/22/2019 10:49 | HITRUN - NO/MINOR    | 3755 AIRPORT WAY | O7         | RPT   | 11/22/2019 14:37:26 |
|          | 11/22/2019 08:51 | INDECEN/LEWDNESS     | 3755 AIRPORT WAY | O19        | NRP   | 11/22/2019 09:10:17 |
| 19004413 | 11/21/2019 08:49 | PAST HIT & RUN -     | 3755 AIRPORT WAY | DESK       | RPT   | 11/21/2019 09:02:59 |
| 19004374 | 11/17/2019 17:48 | SI - FIELD CONTACT   | 3755 AIRPORT WAY | O9         | RPT   | 11/17/2019 18:31:01 |
| 19004368 | 11/16/2019 22:12 | TRESPASS/UNWANTE     | 3755 AIRPORT WAY | O41        | RPT   | 11/16/2019 23:10:00 |
|          | 11/16/2019 13:00 | SI - COMMUNITY       | 3755 AIRPORT WAY | O9         | NRP   | 11/16/2019 13:51:19 |
| 19004321 | 11/11/2019 10:03 | TRESPASS/UNWANTE     | 3755 AIRPORT WAY | O26        | RPT   | 11/11/2019 11:33:44 |
| 19004317 | 11/11/2019 00:05 | SI - FOLLOW-UP       | 3755 AIRPORT WAY | O26        | RPT   | 11/11/2019 12:05:30 |
| 19004317 | 11/10/2019 23:08 | THEFT FROM           | 3755 AIRPORT WAY | O41        | RPT   | 11/11/2019 00:08:33 |
|          | 11/07/2019 21:20 | WANTED PERSON -      | 3755 AIRPORT WAY | O2         | SUBL  | 11/07/2019 21:26:01 |
|          | 11/06/2019 16:22 | WELFARE CHECK        | 3755 AIRPORT WAY | S9         | NRP   | 11/06/2019 17:11:01 |
| 19004213 | 11/02/2019 15:27 | TRESPASS/UNWANTE     | 3755 AIRPORT WAY | O54        | RPT   | 11/02/2019 16:21:51 |
|          | 11/01/2019 16:23 | SUSP                 | 3755 AIRPORT WAY | O39        | NRP   | 11/01/2019 17:21:18 |
| 19004133 | 10/26/2019 18:30 | THEFT - DELTA        | 3755 AIRPORT WAY | O13        | RPT   | 10/26/2019 20:04:39 |
|          | 10/25/2019 16:05 | DISTURBANCE          | 3755 AIRPORT WAY | S8         | NRP   | 10/25/2019 16:22:54 |
|          | 10/24/2019 21:41 | TRESPASS/UNWANTE     | 3755 AIRPORT WAY | O34        | NRP   | 10/24/2019 22:07:11 |
| 19004049 | 10/24/2019 10:01 | SI - FOLLOW-UP       | 3755 AIRPORT WAY | O7         | NRP   | 10/24/2019 13:53:44 |
| 19004091 | 10/23/2019 17:25 | PAST HIT & RUN -     | 3755 AIRPORT WAY | O7         | RPT   | 10/24/2019 10:00:35 |
|          | 10/22/2019 20:27 | KEEP THE PEACE -     | 3755 AIRPORT WAY | O12        | NRP   | 10/22/2019 20:40:51 |
| 19004049 | 10/22/2019 18:42 | FRAUD/FORGERY -      | 3755 AIRPORT WAY | O12        | RPT   | 10/22/2019 19:14:07 |
| 19004065 | 10/21/2019 19:57 | TRESPASS/UNWANTE     | 3755 AIRPORT WAY | O54        | RPT   | 10/21/2019 20:52:01 |
|          | 10/19/2019 12:17 | URGENT WELFARE       | 3755 AIRPORT WAY | O26        | NRP   | 10/19/2019 13:02:26 |
|          | 10/17/2019 20:52 | WANTED PERSON -      | 3755 AIRPORT WAY | O2         | SUBL  | 10/17/2019 21:28:30 |
|          | 10/15/2019 13:52 | DISTURBANCE          | 3755 AIRPORT WAY | O26        | NRP   | 10/15/2019 14:18:46 |
|          | 10/14/2019 18:19 | SUSPICIOUS           | 3755 AIRPORT WAY | O1         | NRP   | 10/14/2019 18:34:41 |
| 19003976 | 10/14/2019 13:53 | PAST THEFT - BRAVO   | 3755 AIRPORT WAY | DESK       | RPT   | 10/14/2019 14:05:04 |
|          | 10/12/2019 19:12 | TRESPASS/UNWANTE     | 3755 AIRPORT WAY | O19        | NRP   | 10/12/2019 19:18:38 |
|          | 10/10/2019 22:20 | 911 HANG-UP -        | 3755 AIRPORT WAY | O34        | NRP   | 10/10/2019 22:42:44 |
| 19003921 | 10/09/2019 15:43 | TRESPASS/UNWANTE     | 3755 AIRPORT WAY | O1         | RPT   | 10/09/2019 19:24:24 |
| 19003876 | 10/05/2019 21:03 | PAST HIT & RUN -     | 3755 AIRPORT WAY | O26        | RPT   | 10/06/2019 01:26:09 |
|          | 10/04/2019 19:11 | SI - FIELD CONTACT   | 3755 AIRPORT WAY | O19        | NRP   | 10/04/2019 19:15:49 |
| 19002495 | 10/04/2019 17:18 | SUPP-                | 3755 AIRPORT WAY | S11        | RPT   | 10/04/2019 17:55:16 |
|          | 10/03/2019 11:22 | SUSPICIOUS           | 3755 AIRPORT WAY | O7         | NRP   | 10/03/2019 11:34:21 |
| 19003819 | 10/01/2019 19:45 | LOCATE               | 3755 AIRPORT WAY |            |       | 10/02/2019 14:03:09 |
| 19003819 | 10/01/2019 18:59 | VEHICLE THEFT -      | 3755 AIRPORT WAY | O13        | RPT   | 10/01/2019 20:30:53 |
| 19003818 | 10/01/2019 18:29 | TRESPASS/UNWANTE     | 3755 AIRPORT WAY | O19        | RPT   | 10/01/2019 19:46:06 |
|          | 09/30/2019 18:41 | PAST DISTURBANCE -   | 3755 AIRPORT WAY | O13        | NRP   | 09/30/2019 19:04:01 |
|          | 09/30/2019 18:15 | SI - FIELD INTERVIEW | 3755 AIRPORT WAY | O13        | NRP   | 09/30/2019 18:58:49 |
|          | 09/30/2019 03:29 | WELFARE CHECK -      | 3755 AIRPORT WAY | O26        | NRP   | 09/30/2019 03:53:18 |
| 19003802 | 09/29/2019 23:17 | THEFT-SUSP DET. &    | 3755 AIRPORT WAY | O26        | RPT   | 09/30/2019 01:13:52 |
|          | 09/29/2019 20:42 | TRESPASS/UNWANTE     | 3755 AIRPORT WAY | O1         | NRP   | 09/29/2019 21:08:59 |



| Report # | Call Time        | Nature               | Location         | Prime Unit | Disp. | Close Time          |
|----------|------------------|----------------------|------------------|------------|-------|---------------------|
| 19003796 | 09/29/2019 20:26 | PAST THEFT - BRAVO   | 3755 AIRPORT WAY | DESK       | RPT   | 09/29/2019 21:24:08 |
| 19003794 | 09/29/2019 13:41 | TRESPASS/UNWANTE     | 3755 AIRPORT WAY | O7         | RPT   | 09/29/2019 17:13:57 |
|          | 09/27/2019 17:32 | TRESPASS/UNWANTE     | 3755 AIRPORT WAY | O19        | NRP   | 09/27/2019 17:37:01 |
|          | 09/27/2019 14:50 | VERBAL DOMESTIC      | 3755 AIRPORT WAY | O19        | NRP   | 09/27/2019 20:01:13 |
| 19003751 | 09/26/2019 21:07 | TRESPASS/UNWANTE     | 3755 AIRPORT WAY | O34        | RPT   | 09/26/2019 22:05:53 |
| 19003749 | 09/26/2019 18:56 | AOA - NON URGENT -   | 3755 AIRPORT WAY | O21        | RPT   | 09/26/2019 21:16:03 |
|          | 09/26/2019 18:43 | MISSING PERSON AT    | 3755 AIRPORT WAY | O29        | NRP   | 09/26/2019 19:33:46 |
| 19003736 | 09/25/2019 15:39 | THEFT - DELTA        | 3755 AIRPORT WAY | O19        | RPT   | 09/25/2019 16:55:53 |
|          | 09/24/2019 18:09 | TRESPASS/UNWANTE     | 3755 AIRPORT WAY | O19        | NRP   | 09/24/2019 18:21:00 |
|          | 09/22/2019 17:24 | TRESPASS/UNWANTE     | 3755 AIRPORT WAY | O1         | NRP   | 09/22/2019 20:19:34 |
| 19003685 | 09/22/2019 10:07 | SI - FIELD CONTACT   | 3755 AIRPORT WAY | O9         | RPT   | 09/22/2019 10:37:03 |
|          | 09/21/2019 16:55 | TRESPASS/UNWANTE     | 3755 AIRPORT WAY | O9         | NRP   | 09/21/2019 17:28:04 |
|          | 09/19/2019 14:05 | PAST HIT & RUN -     | 3755 AIRPORT WAY | O7         | NRP   | 09/19/2019 14:54:30 |
|          | 09/18/2019 14:48 | TRESPASS/UNWANTE     | 3755 AIRPORT WAY | O22        | NRP   | 09/18/2019 15:22:29 |
| 19003605 | 09/17/2019 19:04 | FRAUD/FORGERY -      | 3755 AIRPORT WAY | O19        | RPT   | 09/17/2019 20:36:34 |
| 19003595 | 09/16/2019 17:40 | TRESPASS/UNWANTE     | 3755 AIRPORT WAY | O1         | RPT   | 09/16/2019 18:42:46 |
|          | 09/16/2019 09:16 | DISTURBANCE          | 3755 AIRPORT WAY | O22        | NRP   | 09/16/2019 09:34:03 |
|          | 09/13/2019 09:12 | MVC - UNK INJURIES - | 3755 AIRPORT WAY | O7         | NRP   | 09/13/2019 09:43:28 |
|          | 09/12/2019 18:01 | TRESPASS/UNWANTE     | 3755 AIRPORT WAY | O19        | NRP   | 09/12/2019 18:30:40 |
|          | 09/12/2019 05:46 | URGENT WELFARE       | 3755 AIRPORT WAY | O2         | NRP   | 09/12/2019 06:01:39 |
|          | 09/09/2019 15:38 | DISTURBANCE          | 3755 AIRPORT WAY | L4         | NRP   | 09/09/2019 16:05:02 |
| 19003463 | 09/07/2019 11:54 | SUPP-                | 3755 AIRPORT WAY | O7         | RPT   | 09/07/2019 12:59:37 |
|          | 09/03/2019 13:33 | HIT & RUN            | 3755 AIRPORT WAY | O15        | NRP   | 09/03/2019 14:21:41 |
| 19003320 | 08/28/2019 19:35 | THEFT - OVERRIDE -   | 3755 AIRPORT WAY | O26        | RPT   | 08/28/2019 20:45:56 |
| 19003294 | 08/26/2019 18:15 | DRUGS - USE -        | 3755 AIRPORT WAY | O12        | RPT   | 08/26/2019 19:37:25 |
| 19003251 | 08/23/2019 20:53 | RETAIL THEFT         | 3755 AIRPORT WAY | DESK       | RPT   | 08/23/2019 20:55:06 |
| 19003232 | 08/22/2019 22:21 | RETAIL THEFT         | 3755 AIRPORT WAY | DESK       | RPT   | 08/22/2019 22:24:33 |
|          | 08/22/2019 16:24 | TRESPASS/UNWANTE     | 3755 AIRPORT WAY | O22        | NRP   | 08/22/2019 16:57:37 |
|          | 08/20/2019 22:32 | REDDI                | 3755 AIRPORT WAY | L1         | NRP   | 08/20/2019 22:51:30 |
| 19003167 | 08/20/2019 09:59 | SUPPLEMENTAL-        | 3755 AIRPORT WAY | DESK       | RPT   | 08/20/2019 10:56:25 |
| 19003180 | 08/19/2019 16:02 | DUI - PARKED -       | 3755 AIRPORT WAY | O22        | RPT   | 08/19/2019 18:06:31 |
| 19003167 | 08/18/2019 17:27 | PAST THEFT - BRAVO   | 3755 AIRPORT WAY | O2         | RPT   | 08/18/2019 18:21:11 |
| 19003160 | 08/18/2019 09:01 | THEFT - DELTA        | 3755 AIRPORT WAY | O9         | RPT   | 08/18/2019 09:26:14 |
|          | 08/17/2019 22:44 | SUSPICIOUS VEHICLE   | 3755 AIRPORT WAY | S8         | NRP   | 08/18/2019 00:30:33 |
|          | 08/16/2019 18:51 | FRAUD/FORGERY        | 3755 AIRPORT WAY | I44        | NRP   | 08/16/2019 20:09:02 |
|          | 08/15/2019 20:33 | TRESPASS/UNWANTE     | 3755 AIRPORT WAY | O19        | NRP   | 08/15/2019 20:45:47 |
| 19003130 | 08/15/2019 20:14 | WANTED PERSON -      | 3755 AIRPORT WAY | O12        | RPT   | 08/15/2019 21:33:09 |
| 19003111 | 08/14/2019 19:26 | TRESPASS/UNWANTE     | 3755 AIRPORT WAY | O12        | RPT   | 08/14/2019 21:04:04 |
| 19003077 | 08/12/2019 16:50 | TRESPASS/UNWANTE     | 3755 AIRPORT WAY | O41        | RPT   | 08/12/2019 18:07:25 |
| 19003064 | 08/11/2019 19:00 | THEFT - DELTA        | 3755 AIRPORT WAY | O13        | RPT   | 08/11/2019 19:35:33 |
|          | 08/10/2019 17:16 | TRESPASS/UNWANTE     | 3755 AIRPORT WAY | O29        | NRP   | 08/10/2019 21:34:57 |
| 19003045 | 08/10/2019 13:55 | TRESPASS/UNWANTE     | 3755 AIRPORT WAY | O2         | RPT   | 08/10/2019 14:50:18 |
|          | 08/06/2019 17:52 | TRESPASS/UNWANTE     | 3755 AIRPORT WAY | O13        | NRP   | 08/06/2019 19:00:52 |
| 19002986 | 08/05/2019 20:16 | TRESPASS/UNWANTE     | 3755 AIRPORT WAY | O2         | RPT   | 08/05/2019 20:59:26 |
|          | 08/05/2019 19:36 | DISTURBANCE          | 3755 AIRPORT WAY | L4         | NRP   | 08/05/2019 19:55:49 |

| Report # | Call Time        | Nature             | Location         | Prime Unit | Disp. | Close Time          |
|----------|------------------|--------------------|------------------|------------|-------|---------------------|
| 19002954 | 08/03/2019 22:56 | WANTED PERSON -    | 3755 AIRPORT WAY | O32        | RPT   | 08/03/2019 23:46:30 |
| 19002935 | 08/02/2019 21:29 | TRESPASS/UNWANTE   | 3755 AIRPORT WAY | O21        | RPT   | 08/02/2019 23:01:45 |
| 19002933 | 08/02/2019 17:33 | TRESPASS/UNWANTE   | 3755 AIRPORT WAY | O12        | RPT   | 08/02/2019 18:42:55 |
|          | 08/02/2019 13:19 | TRESPASS/UNWANTE   | 3755 AIRPORT WAY | O2         | NRP   | 08/02/2019 13:45:19 |
|          | 08/01/2019 17:20 | SUSP               | 3755 AIRPORT WAY | O19        | NRP   | 08/01/2019 17:47:31 |
|          | 08/01/2019 07:51 | TRESPASS/UNWANTE   | 3755 AIRPORT WAY | O1         | NRP   | 08/01/2019 08:19:46 |
| 19002906 | 07/31/2019 18:18 | THEFT - DELTA      | 3755 AIRPORT WAY | I44        | RPT   | 07/31/2019 18:40:03 |
|          | 07/31/2019 15:39 | TRESPASS/UNWANTE   | 3755 AIRPORT WAY | O12        | NRP   | 07/31/2019 16:11:49 |
|          | 07/30/2019 20:02 | TRESPASS/UNWANTE   | 3755 AIRPORT WAY | I44        | NRP   | 07/30/2019 20:24:35 |
|          | 07/29/2019 21:32 | TRESPASS/UNWANTE   | 3755 AIRPORT WAY | O5         | NRP   | 07/29/2019 22:00:38 |
|          | 07/28/2019 22:29 | TRESPASS/UNWANTE   | 3755 AIRPORT WAY | S8         | NRP   | 07/28/2019 22:54:33 |
|          | 07/27/2019 15:56 | TRESPASS/UNWANTE   | 3755 AIRPORT WAY | O19        | NRP   | 07/27/2019 16:14:40 |
| 19002836 | 07/27/2019 15:16 | TRESPASS/UNWANTE   | 3755 AIRPORT WAY | O19        | RPT   | 07/27/2019 16:25:02 |
|          | 07/27/2019 10:14 | TRESPASS/UNWANTE   | 3755 AIRPORT WAY | O7         | NRP   | 07/27/2019 10:41:53 |
|          | 07/27/2019 09:55 | SI - AOA           | 3755 AIRPORT WAY | O1         | NRP   | 07/27/2019 10:02:17 |
|          | 07/26/2019 22:29 | TRESPASS/UNWANTE   | 3755 AIRPORT WAY | S8         | NRP   | 07/26/2019 22:57:33 |
| 19002820 | 07/26/2019 21:58 | TRESPASS/UNWANTE   | 3755 AIRPORT WAY | O19        | RPT   | 07/26/2019 22:57:38 |
|          | 07/26/2019 19:46 | TRESPASS/UNWANTE   | 3755 AIRPORT WAY | O19        | NRP   | 07/26/2019 19:58:36 |
| 19002816 | 07/26/2019 15:55 | THEFT - DELTA      | 3755 AIRPORT WAY | O26        | RPT   | 07/26/2019 16:16:13 |
|          | 07/25/2019 19:45 | TRESPASS/UNWANTE   | 3755 AIRPORT WAY | I44        | NRP   | 07/25/2019 19:57:15 |
|          | 07/25/2019 18:59 | TRESPASS/UNWANTE   | 3755 AIRPORT WAY | I44        | NRP   | 07/25/2019 19:41:38 |
|          | 07/25/2019 18:02 | TRESPASS/UNWANTE   | 3755 AIRPORT WAY | O29        | SUBL  | 07/25/2019 18:43:39 |
|          | 07/24/2019 10:35 | TRESPASS/UNWANTE   | 3755 AIRPORT WAY | O2         | NRP   | 07/24/2019 11:23:52 |
| 19002781 | 07/23/2019 15:38 | PAST HIT & RUN -   | 3755 AIRPORT WAY | I44        | RPT   | 07/23/2019 16:59:28 |
| 19002778 | 07/23/2019 15:10 | PAST THEFT - BRAVO | 3755 AIRPORT WAY | DESK       | RPT   | 07/23/2019 15:28:28 |
|          | 07/22/2019 13:12 | ADMINISTRATIVE     | 3755 AIRPORT WAY | O3         | NRP   | 07/22/2019 15:02:36 |
|          | 07/20/2019 22:44 | DUI - PARKED -     | 3755 AIRPORT WAY | O17        | NRP   | 07/20/2019 23:05:59 |
|          | 07/18/2019 16:18 | TRESPASS/UNWANTE   | 3755 AIRPORT WAY | O19        | NRP   | 07/18/2019 16:35:19 |
|          | 07/18/2019 12:49 | SI - FIELD CONTACT | 3755 AIRPORT WAY | O12        | NRP   | 07/18/2019 13:07:28 |
|          | 07/18/2019 12:21 | ROAD RAGE - DELTA  | 3755 AIRPORT WAY | O7         | NRP   | 07/18/2019 12:54:22 |
|          | 07/17/2019 21:24 | DISTURBANCE        | 3755 AIRPORT WAY | O21        | NRP   | 07/17/2019 21:40:28 |
| 19002689 | 07/16/2019 13:40 | TRESPASS/UNWANTE   | 3755 AIRPORT WAY | O9         | RPT   | 07/16/2019 15:32:21 |
|          | 07/14/2019 02:16 | SUSPICIOUS VEHICLE | 3755 AIRPORT WAY | S8         | NRP   | 07/14/2019 02:38:04 |
|          | 07/13/2019 15:01 | TRESPASS/UNWANTE   | 3755 AIRPORT WAY | O19        | NRP   | 07/13/2019 15:47:11 |
|          | 07/13/2019 08:23 | DISTURBANCE        | 3755 AIRPORT WAY | S8         | NRP   | 07/13/2019 09:02:26 |
|          | 07/10/2019 15:45 | LOST PROPERTY -    | 3755 AIRPORT WAY | DESK       | NRP   | 07/10/2019 15:56:55 |
|          | 07/08/2019 22:04 | MINOR TRAF         | 3755 AIRPORT WAY | O5         | NRP   | 07/08/2019 22:39:54 |
|          | 07/02/2019 20:22 | MINOR TRAF         | 3755 AIRPORT WAY | L7         | NRP   | 07/02/2019 20:35:23 |
|          | 06/28/2019 22:20 | TRESPASS/UNWANTE   | 3755 AIRPORT WAY | S3         | NRP   | 06/28/2019 22:47:53 |
|          | 06/28/2019 19:16 | TRESPASS/UNWANTE   | 3755 AIRPORT WAY | I44        | NRP   | 06/28/2019 19:36:07 |
| 19002411 | 06/26/2019 22:05 | TRESPASS/UNWANTE   | 3755 AIRPORT WAY | I44        | RPT   | 06/26/2019 23:08:15 |
| 19002351 | 06/22/2019 21:58 | TRESPASS/UNWANTE   | 3755 AIRPORT WAY | O5         | RPT   | 06/22/2019 22:47:04 |
| 19002326 | 06/21/2019 17:30 | DAMAGE/VANDALISM   | 3755 AIRPORT WAY | S11        | RPT   | 06/21/2019 18:09:46 |
| 19002325 | 06/21/2019 17:00 | PAST THEFT - BRAVO | 3755 AIRPORT WAY | O19        | RPT   | 06/21/2019 18:13:23 |
|          | 06/20/2019 23:00 | TRESPASS/UNWANTE   | 3755 AIRPORT WAY | O34        | NRP   | 06/20/2019 23:21:03 |

| Report # | Call Time        | Nature               | Location         | Prime Unit | Disp. | Close Time          |
|----------|------------------|----------------------|------------------|------------|-------|---------------------|
|          | 06/19/2019 20:44 | HIT & RUN            | 3755 AIRPORT WAY | DESK       | NRP   | 06/19/2019 20:50:01 |
| 19002406 | 06/19/2019 05:59 | DAMAGE/VANDALISM     | 3755 AIRPORT WAY | DESK       | NRP   | 06/19/2019 14:25:28 |
| 19002273 | 06/18/2019 17:26 | TRESPASS/UNWANTE     | 3755 AIRPORT WAY | I44        | RPT   | 06/18/2019 21:00:53 |
|          | 06/17/2019 21:07 | TRESPASS/UNWANTE     | 3755 AIRPORT WAY | O32        | NRP   | 06/17/2019 22:02:28 |
| 19002262 | 06/17/2019 20:28 | DAMAGE/VANDALISM     | 3755 AIRPORT WAY | O32        | RPT   | 06/17/2019 21:59:00 |
|          | 06/16/2019 20:31 | TRESPASS/UNWANTE     | 3755 AIRPORT WAY | O13        | NRP   | 06/16/2019 21:43:35 |
|          | 06/14/2019 17:40 | 10-36                | 3755 AIRPORT WAY | O19        | NRP   | 06/14/2019 17:43:38 |
|          | 06/10/2019 09:38 | PAST HIT & RUN -     | 3755 AIRPORT WAY | DESK       | NRP   | 06/10/2019 09:46:09 |
|          | 06/08/2019 21:23 | TRESPASS/UNWANTE     | 3755 AIRPORT WAY | O29        | SUBL  | 06/08/2019 21:41:47 |
|          | 06/08/2019 17:59 | TRESPASS/UNWANTE     | 3755 AIRPORT WAY | O13        | NRP   | 06/08/2019 18:36:57 |
|          | 06/08/2019 02:52 | AOA - NON URGENT -   | 3755 AIRPORT WAY | O34        | NRP   | 06/08/2019 03:30:05 |
| 19002089 | 06/07/2019 19:08 | THEFT - DELTA        | 3755 AIRPORT WAY | S11        | RPT   | 06/07/2019 19:40:19 |
|          | 06/07/2019 18:45 | TRESPASS/UNWANTE     | 3755 AIRPORT WAY | O25        | NRP   | 06/07/2019 18:55:06 |
|          | 06/07/2019 18:32 | DISTURBANCE -        | 3755 AIRPORT WAY | O25        | NRP   | 06/07/2019 18:46:29 |
|          | 06/06/2019 22:41 | DISTURBANCE          | 3755 AIRPORT WAY | O34        | NRP   | 06/06/2019 23:33:30 |
| 19002075 | 06/06/2019 19:12 | PAST THEFT - BRAVO   | 3755 AIRPORT WAY | O29        | RPT   | 06/06/2019 22:15:32 |
|          | 06/05/2019 20:58 | MINOR TRAF           | 3755 AIRPORT WAY | O29        | SUBL  | 06/05/2019 21:18:46 |
|          | 06/03/2019 22:40 | REDDI                | 3755 AIRPORT WAY | DESK       | NRP   | 06/03/2019 23:11:23 |
| 19002017 | 06/03/2019 14:33 | PAST THEFT - BRAVO   | 3755 AIRPORT WAY | DESK       | RPT   | 06/03/2019 14:41:10 |
|          | 06/03/2019 13:42 | TRESPASS/UNWANTE     | 3755 AIRPORT WAY | S9         | NRP   | 06/03/2019 14:09:53 |
| 19002001 | 06/02/2019 14:48 | WANTED PERSON -      | 3755 AIRPORT WAY | O19        | RPT   | 06/02/2019 16:26:42 |
| 19001984 | 06/01/2019 09:58 | WANTED PERSON -      | 3755 AIRPORT WAY | O1         | RPT   | 06/01/2019 10:57:41 |
|          | 05/31/2019 20:56 | TRESPASS/UNWANTE     | 3755 AIRPORT WAY | O19        | NRP   | 05/31/2019 21:09:04 |
|          | 05/31/2019 16:52 | DISTURBANCE -        | 3755 AIRPORT WAY | O7         | NRP   | 05/31/2019 17:13:35 |
|          | 05/30/2019 20:21 | PAST HIT & RUN -     | 3755 AIRPORT WAY | O19        | NRP   | 05/31/2019 15:16:14 |
|          | 05/28/2019 21:50 | TRESPASS/UNWANTE     | 3755 AIRPORT WAY | O21        | SUBL  | 05/28/2019 21:55:40 |
| 19001932 | 05/28/2019 14:22 | DISTURBANCE -        | 3755 AIRPORT WAY | S9         | RPT   | 05/28/2019 16:47:04 |
| 19001933 | 05/28/2019 11:55 | FRAUD/FORGERY -      | 3755 AIRPORT WAY | O22        | RPT   | 05/28/2019 16:59:19 |
|          | 05/28/2019 11:39 | PAST HIT & RUN -     | 3755 AIRPORT WAY | O15        | NRP   | 05/28/2019 12:05:36 |
|          | 05/28/2019 09:09 | DUI - MOVING - DELTA | 3755 AIRPORT WAY | O3         | NRP   | 05/28/2019 09:35:35 |
|          | 05/26/2019 23:21 | WEAPONS INCIDENT -   | 3755 AIRPORT WAY | O34        | NRP   | 05/26/2019 23:35:07 |
| 19001905 | 05/26/2019 18:28 | PAST THEFT - BRAVO   | 3755 AIRPORT WAY | S11        | RPT   | 05/26/2019 19:24:26 |
| 19001952 | 05/25/2019 18:20 | DAMAGE/VANDALISM     | 3755 AIRPORT WAY | DESK       | NRP   | 05/25/2019 19:38:11 |
|          | 05/25/2019 18:02 | SUSP                 | 3755 AIRPORT WAY | O29        | NRP   | 05/25/2019 18:06:46 |
|          | 05/25/2019 17:37 | TRESPASS/UNWANTE     | 3755 AIRPORT WAY | O29        | NRP   | 05/25/2019 18:02:16 |
|          | 05/25/2019 16:18 | TRESPASS/UNWANTE     | 3755 AIRPORT WAY | O19        | NRP   | 05/25/2019 16:39:15 |
| 19001865 | 05/23/2019 18:51 | RETAIL THEFT         | 3755 AIRPORT WAY | DESK       | RPT   | 05/23/2019 18:53:29 |
|          | 05/21/2019 13:44 | SI - ADMIN           | 3755 AIRPORT WAY | O9         | NRP   | 05/21/2019 13:52:11 |
|          | 05/21/2019 08:45 | SI - ADMIN           | 3755 AIRPORT WAY | O9         | NRP   | 05/21/2019 09:02:35 |
|          | 05/20/2019 16:18 | TRESPASS/UNWANTE     | 3755 AIRPORT WAY | O13        | NRP   | 05/20/2019 16:31:39 |
|          | 05/20/2019 14:49 | TRESPASS/UNWANTE     | 3755 AIRPORT WAY | O13        | NRP   | 05/20/2019 15:58:50 |
|          | 05/19/2019 14:46 | TRESPASS/UNWANTE     | 3755 AIRPORT WAY | O9         | NRP   | 05/19/2019 15:24:45 |
| 19001774 | 05/17/2019 20:25 | THEFT - DELTA        | 3755 AIRPORT WAY | O29        | RPT   | 05/17/2019 21:04:33 |
|          | 05/17/2019 15:09 | TRESPASS/UNWANTE     | 3755 AIRPORT WAY | S11        | NRP   | 05/17/2019 15:44:24 |
|          | 05/16/2019 21:32 | SI - FIELD CONTACT   | 3755 AIRPORT WAY | O5         | NRP   | 05/16/2019 21:37:42 |

| Report # | Call Time        | Nature             | Location         | Prime Unit | Disp. | Close Time          |
|----------|------------------|--------------------|------------------|------------|-------|---------------------|
| 19001704 | 05/13/2019 22:28 | TRESPASS/UNWANTE   | 3755 AIRPORT WAY | O5         | RPT   | 05/13/2019 23:19:24 |
|          | 05/13/2019 10:26 | SI - FLAG DOWN     | 3755 AIRPORT WAY | O9         | NRP   | 05/13/2019 10:45:47 |
|          | 05/11/2019 08:35 | TRESPASS/UNWANTE   | 3755 AIRPORT WAY | O7         | NRP   | 05/11/2019 08:50:38 |
|          | 05/10/2019 19:23 | OFFICER ADVICE     | 3755 AIRPORT WAY | O29        | NRP   | 05/10/2019 20:29:14 |
| 19001621 | 05/08/2019 15:50 | TRESPASS/UNWANTE   | 3755 AIRPORT WAY | O9         | RPT   | 05/08/2019 17:45:31 |
| 19001593 | 05/07/2019 16:11 | SI - FOLLOW-UP     | 3755 AIRPORT WAY | O13        | RPT   | 05/07/2019 17:15:00 |
| 19001593 | 05/07/2019 15:02 | THEFT - DELTA      | 3755 AIRPORT WAY | O13        | RPT   | 05/07/2019 16:00:40 |
|          | 05/06/2019 19:18 | TRESPASS/UNWANTE   | 3755 AIRPORT WAY | O4         | NRP   | 05/06/2019 19:37:27 |
| 19001576 | 05/06/2019 16:24 | WANTED PERSON -    | 3755 AIRPORT WAY | O9         | RPT   | 05/06/2019 17:48:43 |
|          | 05/05/2019 21:12 | WANTED PERSON -    | 3755 AIRPORT WAY | O32        | NRP   | 05/05/2019 21:48:18 |
| 19001538 | 05/04/2019 16:13 | CRIMINAL           | 3755 AIRPORT WAY | O29        | RPT   | 05/04/2019 18:04:01 |
| 19001535 | 05/04/2019 13:32 | WANTED PERSON -    | 3755 AIRPORT WAY | O13        | RPT   | 05/04/2019 14:27:34 |
|          | 05/02/2019 13:30 | DISTURBANCE -      | 3755 AIRPORT WAY | O1         | NRP   | 05/02/2019 13:40:15 |
| 19001499 | 05/01/2019 18:40 | THEFT-SUSP DET. &  | 3755 AIRPORT WAY | S3         | RPT   | 05/01/2019 20:39:19 |
| 19001453 | 04/29/2019 10:57 | WANTED PERSON -    | 3755 AIRPORT WAY | O7         | RPT   | 04/29/2019 12:10:43 |
| 19001447 | 04/28/2019 17:16 | DAMAGE/VANDALISM   | 3755 AIRPORT WAY | O32        | RPT   | 04/28/2019 21:42:14 |
|          | 04/28/2019 16:11 | TRESPASS/UNWANTE   | 3755 AIRPORT WAY | O19        | NRP   | 04/28/2019 16:41:50 |
|          | 04/28/2019 12:39 | FOUND PERSON -     | 3755 AIRPORT WAY | O3         | NRP   | 04/28/2019 13:09:45 |
| 19001423 | 04/26/2019 19:40 | TRESPASS/UNWANTE   | 3755 AIRPORT WAY | O19        | RPT   | 04/26/2019 20:21:11 |
|          | 04/25/2019 06:44 | ADMINISTRATIVE     | 3755 AIRPORT WAY | O9         | NRP   | 04/25/2019 13:04:57 |
|          | 04/24/2019 12:07 | FRAUD -            | 3755 AIRPORT WAY | DESK       | NRP   | 04/24/2019 12:11:58 |
| 19001389 | 04/23/2019 21:15 | PAST VEHICLE THEFT | 3755 AIRPORT WAY | S9         | RPT   | 04/23/2019 22:47:31 |
|          | 04/20/2019 07:17 | DISTURBANCE -      | 3755 AIRPORT WAY | O7         | NRP   | 04/20/2019 07:32:44 |
|          | 04/20/2019 03:28 | SUSP               | 3755 AIRPORT WAY | O5         | NRP   | 04/20/2019 04:18:54 |
|          | 04/19/2019 18:10 | HITRUN - NO/MINOR  | 3755 AIRPORT WAY | O21        | NRP   | 04/19/2019 19:08:41 |
| 19001308 | 04/18/2019 11:06 | PAST THEFT - BRAVO | 3755 AIRPORT WAY | O15        | RPT   | 04/18/2019 12:21:10 |
| 19001295 | 04/17/2019 12:45 | SI - FOLLOW-UP     | 3755 AIRPORT WAY | O9         | RPT   | 04/17/2019 13:26:59 |
| 19001295 | 04/17/2019 11:21 | PAST THEFT - BRAVO | 3755 AIRPORT WAY | O9         | RPT   | 04/17/2019 12:17:00 |
|          | 04/16/2019 14:43 | HIT & RUN          | 3755 AIRPORT WAY | O15        | NRP   | 04/16/2019 14:45:18 |
|          | 04/13/2019 22:03 | TRESPASS/UNWANTE   | 3755 AIRPORT WAY | O13        | NRP   | 04/13/2019 22:24:05 |
|          | 04/12/2019 14:15 | PAST HIT & RUN -   | 3755 AIRPORT WAY | O3         | NRP   | 04/12/2019 14:48:08 |
|          | 04/11/2019 18:02 | SUSPICIOUS         | 3755 AIRPORT WAY | L7         | NRP   | 04/11/2019 19:19:05 |
| 19001212 | 04/10/2019 11:11 | THEFT - OVERRIDE - | 3755 AIRPORT WAY | O9         | RPT   | 04/10/2019 11:47:13 |
|          | 04/09/2019 16:25 | TRESPASS/UNWANTE   | 3755 AIRPORT WAY | O7         | NRP   | 04/09/2019 16:49:44 |
| 19001159 | 04/05/2019 09:51 | PAST THEFT - BRAVO | 3755 AIRPORT WAY | DESK       | RPT   | 04/05/2019 10:21:37 |
| 19001155 | 04/04/2019 21:30 | REDDI              | 3755 AIRPORT WAY | O41        | RPT   | 04/04/2019 22:49:36 |
|          | 04/03/2019 21:00 | SUSP               | 3755 AIRPORT WAY | O5         | NRP   | 04/03/2019 21:17:34 |
| 19001145 | 04/03/2019 18:45 | FOUND PROPERTY -   | 3755 AIRPORT WAY | O4         | RPT   | 04/03/2019 21:12:24 |
|          | 04/02/2019 15:38 | TRESPASS/UNWANTE   | 3755 AIRPORT WAY | O1         | NRP   | 04/02/2019 16:00:51 |
|          | 04/02/2019 15:29 | DISTURBANCE -      | 3755 AIRPORT WAY | O1         | NRP   | 04/02/2019 16:01:13 |
|          | 04/02/2019 14:58 | PAST HIT & RUN -   | 3755 AIRPORT WAY | DESK       | NRP   | 04/02/2019 15:20:23 |
|          | 03/30/2019 11:21 | DISTURBANCE -      | 3755 AIRPORT WAY | O9         | NRP   | 03/30/2019 11:36:07 |
|          | 03/29/2019 20:09 | TRESPASS/UNWANTE   | 3755 AIRPORT WAY | O13        | NRP   | 03/29/2019 20:31:32 |
|          | 03/28/2019 15:29 | TRESPASS/UNWANTE   | 3755 AIRPORT WAY | O17        | NRP   | 03/28/2019 15:53:55 |
|          | 03/28/2019 13:27 | DISTURBANCE -      | 3755 AIRPORT WAY | O9         | NRP   | 03/28/2019 13:54:56 |



| Report # | Call Time        | Nature               | Location         | Prime Unit | Disp. | Close Time          |
|----------|------------------|----------------------|------------------|------------|-------|---------------------|
| 19001055 | 03/27/2019 18:37 | PAST HIT & RUN -     | 3755 AIRPORT WAY | O17        | RPT   | 03/27/2019 20:29:11 |
|          | 03/27/2019 18:00 | DISTURBANCE -        | 3755 AIRPORT WAY | O41        | NRP   | 03/27/2019 23:56:18 |
| 19001031 | 03/25/2019 19:12 | DUI - MOVING - DELTA | 3755 AIRPORT WAY | O19        | RPT   | 03/25/2019 20:40:37 |
|          | 03/24/2019 15:01 | URGENT WELFARE       | 3755 AIRPORT WAY | O3         | NRP   | 03/24/2019 15:22:32 |
| 19001004 | 03/23/2019 18:19 | SUSP                 | 3755 AIRPORT WAY | O41        | RPT   | 03/23/2019 20:04:32 |
|          | 03/22/2019 13:58 | FRAUD/FORGERY -      | 3755 AIRPORT WAY | O15        | NRP   | 03/22/2019 14:37:37 |
|          | 03/21/2019 07:15 | ADMINISTRATIVE       | 3755 AIRPORT WAY | O15        | NRP   | 03/22/2019 07:32:32 |
|          | 03/19/2019 21:20 | DISTURBANCE -        | 3755 AIRPORT WAY | O34        | NRP   | 03/19/2019 21:41:15 |
|          | 03/19/2019 17:19 | DISTURBANCE -        | 3755 AIRPORT WAY | S11        | NRP   | 03/19/2019 18:00:03 |
|          | 03/19/2019 13:40 | HIT & RUN            | 3755 AIRPORT WAY | O15        | NRP   | 03/19/2019 13:55:30 |

Total Number of Events Listed: **366**

**CITY OF FAIRBANKS PUBLIC SAFETY**

**Raven Landing Center 949 McGown Street**

03/19/2019 - 03/17/2020

| <b>Report #</b> | <b>Call Time</b> | <b>Nature</b>   | <b>Location</b> | <b>Prime Unit</b> | <b>Disp.</b> | <b>Close Time</b>   |
|-----------------|------------------|-----------------|-----------------|-------------------|--------------|---------------------|
|                 | 09/15/2019 17:39 | URGENT WELFARE  | 949 MCGOWN ST   | O1                | NRP          | 09/15/2019 17:52:26 |
| 19003330        | 08/29/2019 11:59 | PAST BURGLARY - | 949 MCGOWN ST   | O2                | RPT          | 08/29/2019 13:12:21 |

Total Number of Events Listed: **2**

**CITY OF FAIRBANKS PUBLIC SAFETY**

**American Legion Post 11 129 First Avenue**

03/19/2019 - 03/17/2020

| Report # | Call Time        | Nature             | Location      | Prime Unit | Disp. | Close Time          |
|----------|------------------|--------------------|---------------|------------|-------|---------------------|
| 20000163 | 01/15/2020 20:39 | PAST THEFT - BRAVO | 129 FIRST AVE | DESK       | RPT   | 01/15/2020 20:53:13 |
| 19004132 | 10/26/2019 17:47 | ASSAULT - BRAVO    | 129 FIRST AVE | O13        | RPT   | 10/26/2019 18:46:06 |
|          | 10/19/2019 12:27 | CIVIL PROBLEM      | 129 FIRST AVE | O7         | NRP   | 10/19/2019 13:36:23 |
|          | 05/04/2019 12:18 | DISTURBANCE -      | 129 FIRST AVE | O41        | NRP   | 05/04/2019 12:33:54 |

Total Number of Events Listed: 4

**CITY OF FAIRBANKS PUBLIC SAFETY**

**Hoarfrost Distilling 3501 Lathrop Street**

03/19/2019 - 03/17/2020

| <b>Report #</b> | <b>Call Time</b> | <b>Nature</b>       | <b>Location</b> | <b>Prime Unit</b> | <b>Disp.</b> | <b>Close Time</b>   |
|-----------------|------------------|---------------------|-----------------|-------------------|--------------|---------------------|
|                 | 11/06/2019 20:02 | SI - SECURITY CHECK | 3501 LATHROP ST | O19               | NRP          | 11/06/2019 20:09:33 |
|                 | 11/01/2019 14:56 | PRIVATE IMPOUND     | 3501 LATHROP ST | O19               | NRP          | 11/01/2019 17:08:05 |

Total Number of Events Listed: **2**

Incident / Event (Search) ✕

Link Event ID  Call recv 03/19/2019 00:00:00 AVL  Report

Print

Event Info | Notes | Times | R/E Log | Other | Log Entry | Ani/Ali | Patients | Employee | Names | Vehicles

---

Rpt#  Source  PU  EMS Fire Law Resc Othr

Loc 3101 PEGER RD FAIR

X-ST Jur  Service  Agency FPD

Stat/Beat  District  RA

Busi ODOM COMPANY Ph# ( ) - Call group

---

Nature  QA

Caller  Hist Alarm

Address  SOS

Veh#  To RMS Send Export

---

Include delayed events  Include cancelled events View Text Re-Open

---

← Prev → Next + Add 📄 Duplicate 🗑 Delete 🔍 Search 📄 View ✕ Exit Srch

ONESolution CAD ✕

No match found.

Ok

# CITY OF FAIRBANKS PUBLIC SAFETY

Irashai Japanese Restaurant 419 Merhar Avenue

03/19/2019 - 03/17/2020

| Report # | Call Time        | Nature             | Location       | Prime Unit | Disp. | Close Time          |
|----------|------------------|--------------------|----------------|------------|-------|---------------------|
|          | 12/23/2019 17:10 | AOA - NON URGENT - | 419 MERHAR AVE | O9         | NRP   | 12/23/2019 17:31:59 |
| 19004707 | 12/15/2019 19:26 | SUPP-              | 419 MERHAR AVE | O53        | RPT   | 12/15/2019 21:33:09 |
| 19004707 | 12/15/2019 17:34 | PAST THEFT - BRAVO | 419 MERHAR AVE | O53        | RPT   | 12/15/2019 18:14:32 |
|          | 11/01/2019 19:30 | REDDI              | 419 MERHAR AVE | S9         | NRP   | 11/01/2019 19:42:51 |
| 19003164 | 10/11/2019 10:54 | SI - FOLLOW-UP     | 419 MERHAR AVE | O7         | NRP   | 10/11/2019 11:07:03 |

Total Number of Events Listed: 5

# CITY OF FAIRBANKS PUBLIC SAFETY

**Holiday #622 2300 S. Cushman Street**

03/19/2019 - 03/17/2020

| Report # | Call Time        | Nature              | Location          | Prime Unit | Disp. | Close Time          |
|----------|------------------|---------------------|-------------------|------------|-------|---------------------|
|          | 03/08/2020 12:30 | MVC - NO INJURIES - | 2300 S CUSHMAN ST | DESK       | NRP   | 03/08/2020 12:41:06 |
| 20000788 | 03/08/2020 04:02 | DISTURBANCE         | 2300 S CUSHMAN ST | O2         | RPT   | 03/08/2020 06:35:20 |
|          | 03/08/2020 00:03 | TRESPASS/UNWANTE    | 2300 S CUSHMAN ST | O52        | NRP   | 03/08/2020 00:22:59 |
| 20000780 | 03/07/2020 13:22 | THEFT - DELTA       | 2300 S CUSHMAN ST | O7         | RPT   | 03/07/2020 17:11:57 |
|          | 03/02/2020 01:55 | SI - SECURITY CHECK | 2300 S CUSHMAN ST | O2         | NRP   | 03/02/2020 01:59:18 |
|          | 03/01/2020 16:02 | SUSPICIOUS PERSON   | 2300 S CUSHMAN ST | O7         | NRP   | 03/01/2020 16:39:18 |
|          | 02/29/2020 18:53 | TRESPASS/UNWANTE    | 2300 S CUSHMAN ST | O54        | NRP   | 02/29/2020 19:50:59 |
|          | 02/25/2020 14:59 | REDDI               | 2300 S CUSHMAN ST | DESK       | NRP   | 02/25/2020 15:41:47 |
|          | 02/24/2020 12:13 | MENTAL DISORDER -   | 2300 S CUSHMAN ST | S3         | NRP   | 02/24/2020 12:40:44 |
|          | 02/23/2020 01:16 | SI - FIELD CONTACT  | 2300 S CUSHMAN ST | O41        | NRP   | 02/23/2020 01:37:36 |
| 20000602 | 02/21/2020 10:15 | DAMAGE/VANDALISM    | 2300 S CUSHMAN ST | O9         | RPT   | 02/21/2020 13:31:55 |
| 20000493 | 02/16/2020 00:06 | SI - FOLLOW-UP      | 2300 S CUSHMAN ST | O17        | NRP   | 02/16/2020 00:37:48 |
| 20000520 | 02/15/2020 04:55 | SI - FOLLOW-UP      | 2300 S CUSHMAN ST | O9         | RPT   | 02/15/2020 10:57:00 |
| 20000520 | 02/15/2020 01:42 | THEFT - DELTA       | 2300 S CUSHMAN ST | O41        | RPT   | 02/15/2020 02:56:02 |
| 20000493 | 02/12/2020 18:02 | TRESPASS/UNWANTE    | 2300 S CUSHMAN ST | O17        | RPT   | 02/12/2020 20:58:49 |
|          | 02/12/2020 17:34 | SEND PROTOCOL       | 2300 S CUSHMAN ST | S9         | NRP   | 02/12/2020 17:58:16 |
|          | 02/10/2020 22:51 | SUSPICIOUS          | 2300 S CUSHMAN ST | O34        | SUBL  | 02/10/2020 23:34:13 |
|          | 02/08/2020 22:43 | SI - FIELD CONTACT  | 2300 S CUSHMAN ST | O41        | NRP   | 02/08/2020 23:13:00 |
|          | 02/07/2020 15:58 | MVC - NO INJURIES - | 2300 S CUSHMAN ST | DESK       | NRP   | 02/07/2020 16:16:58 |
|          | 02/05/2020 20:18 | SI - SECURITY CHECK | 2300 S CUSHMAN ST | O17        | NRP   | 02/05/2020 20:25:56 |
|          | 02/05/2020 16:44 | TRESPASS/UNWANTE    | 2300 S CUSHMAN ST | L5         | NRP   | 02/05/2020 18:26:48 |
|          | 01/25/2020 17:33 | SUSP                | 2300 S CUSHMAN ST | O52        | NRP   | 01/25/2020 18:13:57 |
|          | 01/24/2020 20:36 | SI - SECURITY CHECK | 2300 S CUSHMAN ST | L3         | NRP   | 01/24/2020 20:43:13 |
|          | 01/22/2020 15:05 | PAST MVC - ALPHA    | 2300 S CUSHMAN ST | O53        | NRP   | 01/22/2020 16:38:50 |
|          | 01/19/2020 16:54 | LOST PROPERTY -     | 2300 S CUSHMAN ST | O29        | NRP   | 01/20/2020 01:16:40 |
|          | 01/16/2020 04:08 | 10-36               | 2300 S CUSHMAN ST | O53        | UTC   | 01/16/2020 05:14:46 |
| 20000165 | 01/15/2020 23:43 | SI - FIELD CONTACT  | 2300 S CUSHMAN ST | O54        | RPT   | 01/16/2020 02:26:24 |
|          | 01/11/2020 03:13 | WELFARE CHECK -     | 2300 S CUSHMAN ST | O16        | NRP   | 01/11/2020 03:32:50 |
|          | 01/08/2020 02:49 | ALARM BURGLARY -    | 2300 S CUSHMAN ST | O2         | FAB   | 01/08/2020 02:54:51 |
| 20000060 | 01/07/2020 02:45 | TRESPASS/UNWANTE    | 2300 S CUSHMAN ST | O26        | RPT   | 01/07/2020 03:42:01 |
|          | 01/06/2020 04:34 | SI - SECURITY CHECK | 2300 S CUSHMAN ST | O2         | SUBL  | 01/06/2020 04:40:02 |
|          | 01/03/2020 00:04 | ALARM               | 2300 S CUSHMAN ST | O19        | FAB   | 01/03/2020 00:15:25 |
|          | 12/28/2019 01:57 | SUPPLEMENTAL-       | 2300 S CUSHMAN ST | S11        | NRP   | 12/28/2019 02:18:33 |
| 19004800 | 12/22/2019 19:10 | TRESPASS/UNWANTE    | 2300 S CUSHMAN ST | O53        | RPT   | 12/22/2019 20:09:06 |
| 19004726 | 12/17/2019 16:24 | PAST HIT & RUN -    | 2300 S CUSHMAN ST | O52        | RPT   | 12/17/2019 18:00:16 |
|          | 12/15/2019 04:24 | TRESPASS/UNWANTE    | 2300 S CUSHMAN ST | O5         | NRP   | 12/15/2019 04:35:11 |
| 19004620 | 12/07/2019 05:06 | SUSP                | 2300 S CUSHMAN ST | O2         | RPT   | 12/07/2019 07:29:42 |
| 19004590 | 12/05/2019 02:33 | ROB PERSONAL -      | 2300 S CUSHMAN ST | O41        | RPT   | 12/05/2019 03:16:08 |
|          | 12/04/2019 20:57 | TRESPASS/UNWANTE    | 2300 S CUSHMAN ST | O26        | NRP   | 12/04/2019 21:33:19 |
|          | 11/28/2019 11:18 | SI - FIELD CONTACT  | 2300 S CUSHMAN ST | I42        | NRP   | 11/28/2019 11:26:55 |
|          | 11/25/2019 23:53 | SI - SECURITY CHECK | 2300 S CUSHMAN ST | S3         | NRP   | 11/25/2019 23:56:16 |

| Report # | Call Time        | Nature               | Location          | Prime Unit | Disp. | Close Time          |
|----------|------------------|----------------------|-------------------|------------|-------|---------------------|
|          | 11/25/2019 05:25 | ALARM                | 2300 S CUSHMAN ST | O34        | NRP   | 11/25/2019 05:40:39 |
|          | 11/25/2019 01:56 | INCAPACITATED        | 2300 S CUSHMAN ST | O41        | NRP   | 11/25/2019 02:42:59 |
| 19004411 | 11/21/2019 03:05 | DISTURBANCE          | 2300 S CUSHMAN ST | O32        | RPT   | 11/21/2019 03:32:08 |
| 19004404 | 11/19/2019 14:07 | PAST THEFT - BRAVO   | 2300 S CUSHMAN ST | O4         | RPT   | 11/20/2019 08:47:42 |
| 19004389 | 11/19/2019 00:40 | TRESPASS/UNWANTE     | 2300 S CUSHMAN ST | O34        | RPT   | 11/19/2019 03:03:40 |
|          | 11/19/2019 00:00 | 10-36                | 2300 S CUSHMAN ST | O54        | WAR   | 11/19/2019 00:04:38 |
|          | 11/18/2019 23:19 | TRESPASS/UNWANTE     | 2300 S CUSHMAN ST | O54        | NRP   | 11/18/2019 23:50:09 |
|          | 11/17/2019 18:19 | MVC - UNK INJURIES - | 2300 S CUSHMAN ST | O29        | NRP   | 11/17/2019 18:55:24 |
|          | 11/15/2019 23:13 | 10-36                | 2300 S CUSHMAN ST | O5         | NRP   | 11/15/2019 23:14:55 |
|          | 11/14/2019 17:30 | TRESPASS/UNWANTE     | 2300 S CUSHMAN ST | S9         | NRP   | 11/14/2019 18:05:48 |
|          | 11/08/2019 20:05 | DUI - PARKED -       | 2300 S CUSHMAN ST | O54        | NRP   | 11/08/2019 20:21:22 |
|          | 11/06/2019 23:55 | ALARM OTHER -        | 2300 S CUSHMAN ST | O2         | NRP   | 11/07/2019 00:19:22 |
|          | 10/28/2019 17:39 | TRESPASS/UNWANTE     | 2300 S CUSHMAN ST | O13        | NRP   | 10/28/2019 17:56:42 |
|          | 10/25/2019 22:21 | 10-36                | 2300 S CUSHMAN ST | O26        | UTC   | 10/25/2019 23:03:15 |
|          | 10/24/2019 04:19 | 10-36                | 2300 S CUSHMAN ST | O16        | UTC   | 10/24/2019 04:44:50 |
|          | 10/24/2019 02:37 | DISTURBANCE          | 2300 S CUSHMAN ST | L1         | NRP   | 10/24/2019 02:43:49 |
| 19003985 | 10/15/2019 02:31 | 10-36                | 2300 S CUSHMAN ST | O12        | RPT   | 10/15/2019 07:46:11 |
|          | 10/12/2019 18:40 | INCAPACITATED        | 2300 S CUSHMAN ST | O32        | NRP   | 10/12/2019 19:13:25 |
|          | 10/08/2019 13:08 | WEAPONS INCIDENT     | 2300 S CUSHMAN ST | O22        | NRP   | 10/08/2019 13:18:16 |
|          | 10/08/2019 03:02 | SI - SECURITY CHECK  | 2300 S CUSHMAN ST | O26        | NRP   | 10/08/2019 03:07:33 |
|          | 10/06/2019 01:52 | SI - SECURITY CHECK  | 2300 S CUSHMAN ST | O26        | NRP   | 10/06/2019 01:59:27 |
|          | 10/04/2019 15:59 | TRESPASS/UNWANTE     | 2300 S CUSHMAN ST | S8         | NRP   | 10/04/2019 16:25:20 |
| 19003171 | 10/04/2019 15:03 | SUPP-                | 2300 S CUSHMAN ST | DESK       | RPT   | 10/04/2019 15:16:47 |
|          | 10/03/2019 10:37 | URGENT WELFARE       | 2300 S CUSHMAN ST | O3         | NRP   | 10/03/2019 10:54:44 |
| 19003809 | 10/03/2019 07:59 | SI - FOLLOW-UP       | 2300 S CUSHMAN ST | O3         | RPT   | 10/03/2019 12:40:12 |
| 19003813 | 10/01/2019 02:24 | DISTURBANCE          | 2300 S CUSHMAN ST | S3         | RPT   | 10/01/2019 04:30:23 |
|          | 09/30/2019 04:07 | SI - FIELD CONTACT   | 2300 S CUSHMAN ST | O26        | NRP   | 09/30/2019 04:23:42 |
|          | 09/27/2019 21:28 | DISTURBANCE          | 2300 S CUSHMAN ST | O21        | SUBL  | 09/27/2019 21:38:41 |
|          | 09/22/2019 17:54 | WELFARE CHECK -      | 2300 S CUSHMAN ST | O1         | NRP   | 09/22/2019 18:25:27 |
|          | 09/22/2019 14:04 | INDECEN/LEWDNESS     | 2300 S CUSHMAN ST | O9         | NRP   | 09/22/2019 14:14:48 |
| 19003682 | 09/22/2019 00:54 | 10-36                | 2300 S CUSHMAN ST | O5         | RPT   | 09/22/2019 02:19:22 |
|          | 09/19/2019 23:00 | 10-36                | 2300 S CUSHMAN ST | O12        | WAR   | 09/19/2019 23:14:24 |
|          | 09/19/2019 16:01 | REDDI                | 2300 S CUSHMAN ST | DESK       | NRP   | 09/19/2019 16:32:24 |
|          | 09/19/2019 02:04 | SUSP                 | 2300 S CUSHMAN ST | O34        | NRP   | 09/19/2019 02:29:03 |
|          | 09/17/2019 18:13 | SI -VID              | 2300 S CUSHMAN ST | O41        | NRP   | 09/17/2019 18:13:40 |
|          | 09/17/2019 04:10 | SI - FIELD CONTACT   | 2300 S CUSHMAN ST | O9         | NRP   | 09/17/2019 04:17:41 |
|          | 09/17/2019 03:48 | SUSP                 | 2300 S CUSHMAN ST | O5         | NRP   | 09/17/2019 04:11:05 |
|          | 09/17/2019 01:58 | 10-36                | 2300 S CUSHMAN ST | O5         | WAR   | 09/17/2019 02:08:43 |
|          | 09/16/2019 11:59 | WANTED PERSON -      | 2300 S CUSHMAN ST | O13        | NRP   | 09/16/2019 12:14:09 |
|          | 09/15/2019 21:23 | MINOR TRAF           | 2300 S CUSHMAN ST | O41        | NRP   | 09/15/2019 21:40:38 |
|          | 09/15/2019 03:28 | 10-36                | 2300 S CUSHMAN ST | O16        | WAR   | 09/15/2019 03:32:43 |
|          | 09/14/2019 21:47 | 10-36                | 2300 S CUSHMAN ST | O16        | WAR   | 09/14/2019 21:52:41 |
|          | 09/14/2019 18:12 | TRESPASS/UNWANTE     | 2300 S CUSHMAN ST | O29        | NRP   | 09/14/2019 18:32:23 |
|          | 09/14/2019 03:32 | SI - AOA             | 2300 S CUSHMAN ST | O41        | NRP   | 09/14/2019 03:47:00 |
|          | 09/11/2019 23:57 | SI - SECURITY CHECK  | 2300 S CUSHMAN ST | O21        | NRP   | 09/12/2019 00:04:45 |



| Report # | Call Time        | Nature               | Location          | Prime Unit | Disp. | Close Time          |
|----------|------------------|----------------------|-------------------|------------|-------|---------------------|
| 19003529 | 09/11/2019 18:24 | PAST THEFT - BRAVO   | 2300 S CUSHMAN ST | L4         | RPT   | 09/11/2019 19:58:39 |
|          | 09/10/2019 20:10 | DISTURBANCE          | 2300 S CUSHMAN ST | L4         | NRP   | 09/10/2019 20:33:02 |
| 19003497 | 09/08/2019 20:56 | DISTURBANCE          | 2300 S CUSHMAN ST | O29        | RPT   | 09/08/2019 21:33:02 |
| 19003484 | 09/08/2019 05:39 | DISTURBANCE          | 2300 S CUSHMAN ST | O2         | RPT   | 09/08/2019 06:19:20 |
| 19003479 | 09/07/2019 21:09 | DISTURBANCE          | 2300 S CUSHMAN ST | O41        | RPT   | 09/07/2019 21:49:00 |
|          | 09/05/2019 15:21 | TRESPASS/UNWANTE     | 2300 S CUSHMAN ST | O3         | NRP   | 09/05/2019 15:39:30 |
|          | 09/03/2019 20:26 | SI - FLAG DOWN       | 2300 S CUSHMAN ST | O12        | NRP   | 09/03/2019 20:43:28 |
|          | 09/01/2019 23:46 | SI - SECURITY CHECK  | 2300 S CUSHMAN ST | O41        | NRP   | 09/01/2019 23:48:11 |
|          | 09/01/2019 23:20 | OFFICER ADVICE       | 2300 S CUSHMAN ST | O32        | NRP   | 09/02/2019 00:21:36 |
| 19003367 | 09/01/2019 00:40 | PAST THEFT - BRAVO   | 2300 S CUSHMAN ST | O5         | RPT   | 09/01/2019 01:12:36 |
| 19003292 | 08/26/2019 12:52 | ASSAULT - BRAVO      | 2300 S CUSHMAN ST | O4         | RPT   | 08/26/2019 15:40:11 |
|          | 08/21/2019 08:54 | SUSP                 | 2300 S CUSHMAN ST | O9         | NRP   | 08/21/2019 09:19:17 |
|          | 08/20/2019 12:45 | PAST DISTURBANCE -   | 2300 S CUSHMAN ST | O3         | NRP   | 08/20/2019 13:38:45 |
|          | 08/19/2019 14:27 | DISTURBANCE          | 2300 S CUSHMAN ST | O9         | NRP   | 08/19/2019 14:50:43 |
|          | 08/17/2019 15:24 | SI - FIELD CONTACT   | 2300 S CUSHMAN ST | O2         | NRP   | 08/17/2019 15:26:19 |
|          | 08/16/2019 15:25 | DISTURBANCE          | 2300 S CUSHMAN ST | O26        | NRP   | 08/16/2019 16:02:56 |
|          | 08/15/2019 08:15 | SUSPICIOUS PERSON    | 2300 S CUSHMAN ST | O1         | NRP   | 08/15/2019 09:16:40 |
| 19003101 | 08/14/2019 07:36 | DISTURBANCE          | 2300 S CUSHMAN ST | O2         | RPT   | 08/14/2019 14:04:12 |
|          | 08/11/2019 11:28 | SI - FLAG DOWN       | 2300 S CUSHMAN ST | O2         | WAR   | 08/11/2019 11:32:23 |
|          | 08/10/2019 21:39 | VIOLATION OF CRT     | 2300 S CUSHMAN ST | O17        | NRP   | 08/10/2019 23:07:27 |
| 19003063 | 08/10/2019 18:48 | FRAUD/FORGERY -      | 2300 S CUSHMAN ST | O19        | RPT   | 08/11/2019 17:06:27 |
|          | 08/10/2019 02:51 | SI - SECURITY CHECK  | 2300 S CUSHMAN ST | O21        | NRP   | 08/10/2019 02:55:01 |
|          | 08/09/2019 16:10 | REDDI                | 2300 S CUSHMAN ST | DESK       | NRP   | 08/09/2019 16:38:15 |
|          | 08/09/2019 15:10 | LOST PROPERTY -      | 2300 S CUSHMAN ST | DESK       | NRP   | 08/09/2019 15:30:29 |
|          | 08/09/2019 04:52 | TRESPASS/UNWANTE     | 2300 S CUSHMAN ST | O34        | NRP   | 08/09/2019 05:30:27 |
| 19003027 | 08/09/2019 00:36 | TRESPASS/UNWANTE     | 2300 S CUSHMAN ST | O21        | RPT   | 08/09/2019 01:12:40 |
|          | 08/08/2019 21:56 | TRESPASS/UNWANTE     | 2300 S CUSHMAN ST | S8         | NRP   | 08/08/2019 22:24:59 |
|          | 08/06/2019 10:13 | SI - FIELD CONTACT   | 2300 S CUSHMAN ST | O9         | NRP   | 08/06/2019 10:21:44 |
|          | 08/06/2019 05:36 | AOA - NON URGENT -   | 2300 S CUSHMAN ST | O5         | NRP   | 08/06/2019 05:43:43 |
|          | 08/01/2019 04:57 | TRESPASS/UNWANTE     | 2300 S CUSHMAN ST | O1         | NRP   | 08/01/2019 05:10:13 |
|          | 07/31/2019 19:37 | DISTURBANCE          | 2300 S CUSHMAN ST | S3         | NRP   | 07/31/2019 22:47:47 |
|          | 07/30/2019 15:09 | 10-36                | 2300 S CUSHMAN ST | O41        | WAR   | 07/30/2019 15:15:20 |
|          | 07/30/2019 02:55 | SUSPICIOUS           | 2300 S CUSHMAN ST | O5         | NRP   | 07/30/2019 03:55:19 |
|          | 07/30/2019 01:25 | 10-36                | 2300 S CUSHMAN ST | O32        | WAR   | 07/30/2019 01:29:46 |
|          | 07/28/2019 06:15 | SUSPICIOUS PERSON    | 2300 S CUSHMAN ST | S8         | NRP   | 07/28/2019 06:30:45 |
| 19002847 | 07/28/2019 03:57 | VEHICLE THEFT -      | 2300 S CUSHMAN ST | O2         | RPT   | 07/28/2019 04:53:34 |
|          | 07/26/2019 16:48 | TRESPASS/UNWANTE     | 2300 S CUSHMAN ST | O1         | NRP   | 07/26/2019 17:01:06 |
|          | 07/24/2019 06:13 | TRESPASS/UNWANTE     | 2300 S CUSHMAN ST | O5         | NRP   | 07/24/2019 06:27:31 |
|          | 07/24/2019 05:09 | TRESPASS/UNWANTE     | 2300 S CUSHMAN ST | O5         | NRP   | 07/24/2019 05:21:53 |
| 19002721 | 07/18/2019 21:36 | AOA - NON URGENT -   | 2300 S CUSHMAN ST | O29        | RPT   | 07/18/2019 22:07:53 |
| 19002705 | 07/18/2019 02:35 | MENTAL DISORDER -    | 2300 S CUSHMAN ST | O29        | RPT   | 07/18/2019 03:28:28 |
|          | 07/16/2019 21:58 | SI - FIELD INTERVIEW | 2300 S CUSHMAN ST | O32        | NRP   | 07/16/2019 22:25:32 |
|          | 07/16/2019 20:37 | SUSP                 | 2300 S CUSHMAN ST | O13        | NRP   | 07/16/2019 20:56:29 |
|          | 07/16/2019 01:01 | URGENT WELFARE       | 2300 S CUSHMAN ST | S8         | NRP   | 07/16/2019 01:20:20 |
| 19002672 | 07/14/2019 18:15 | FRAUD/FORGERY -      | 2300 S CUSHMAN ST | O22        | RPT   | 07/15/2019 12:13:17 |

| Report # | Call Time        | Nature              | Location          | Prime Unit | Disp. | Close Time          |
|----------|------------------|---------------------|-------------------|------------|-------|---------------------|
|          | 07/14/2019 15:50 | PAST HIT & RUN -    | 2300 S CUSHMAN ST | DESK       | NRP   | 07/14/2019 16:39:19 |
|          | 07/12/2019 13:50 | SUSP                | 2300 S CUSHMAN ST | O1         | NRP   | 07/13/2019 16:26:40 |
|          | 07/12/2019 02:45 | 911 HANG-UP -       | 2300 S CUSHMAN ST | O34        | NRP   | 07/12/2019 02:59:15 |
|          | 07/12/2019 00:19 | PROSTITUTION -      | 2300 S CUSHMAN ST | O19        | NRP   | 07/12/2019 00:34:35 |
|          | 07/11/2019 19:01 | SUSP                | 2300 S CUSHMAN ST | S3         | NRP   | 07/11/2019 19:44:23 |
|          | 07/11/2019 14:35 | SUSPICIOUS VEHICLE  | 2300 S CUSHMAN ST | I44        | NRP   | 07/11/2019 15:21:42 |
|          | 07/08/2019 19:21 | MENTAL DISORDER -   | 2300 S CUSHMAN ST | O13        | NRP   | 07/08/2019 19:50:48 |
|          | 07/07/2019 22:00 | DISTURBANCE         | 2300 S CUSHMAN ST | O19        | NRP   | 07/07/2019 22:07:37 |
|          | 07/05/2019 22:44 | REDDI               | 2300 S CUSHMAN ST | O17        | NRP   | 07/05/2019 23:00:53 |
|          | 07/04/2019 12:42 | UNKNOWN             | 2300 S CUSHMAN ST | O22        | NRP   | 07/04/2019 13:46:04 |
| 19002479 | 07/02/2019 12:50 | SI - FOLLOW-UP      | 2300 S CUSHMAN ST | I41        | RPT   | 07/02/2019 13:31:40 |
|          | 07/02/2019 04:04 | SUPP-               | 2300 S CUSHMAN ST | S8         | NRP   | 07/02/2019 04:39:29 |
|          | 06/29/2019 20:08 | DISTURBANCE         | 2300 S CUSHMAN ST | O19        | NRP   | 06/29/2019 20:20:46 |
|          | 06/20/2019 20:18 | TRESPASS/UNWANTE    | 2300 S CUSHMAN ST | S3         | NRP   | 06/20/2019 20:55:44 |
| 19002240 | 06/15/2019 21:58 | PAST THEFT - BRAVO  | 2300 S CUSHMAN ST | O32        | RPT   | 06/15/2019 23:35:33 |
|          | 06/15/2019 03:39 | INCAPACITATED       | 2300 S CUSHMAN ST | S8         | NRP   | 06/15/2019 04:07:41 |
|          | 06/14/2019 22:34 | DAMAGE/VANDALISM    | 2300 S CUSHMAN ST | O17        | NRP   | 06/14/2019 23:01:07 |
|          | 06/13/2019 05:46 | TRESPASS/UNWANTE    | 2300 S CUSHMAN ST | O17        | NRP   | 06/13/2019 06:00:09 |
|          | 06/10/2019 00:10 | TRESPASS/UNWANTE    | 2300 S CUSHMAN ST | O34        | NRP   | 06/10/2019 00:24:39 |
|          | 06/06/2019 11:55 | DUI - MOVING -      | 2300 S CUSHMAN ST | DESK       | NRP   | 06/06/2019 12:40:41 |
|          | 06/02/2019 23:12 | SI - FIELD CONTACT  | 2300 S CUSHMAN ST | O34        | NRP   | 06/02/2019 23:31:11 |
| 19001977 | 05/31/2019 23:54 | TRESPASS/UNWANTE    | 2300 S CUSHMAN ST | O34        | RPT   | 06/01/2019 01:32:07 |
|          | 05/30/2019 19:03 | REDDI               | 2300 S CUSHMAN ST | O25        | NRP   | 05/30/2019 19:17:20 |
|          | 05/28/2019 15:29 | REDDI               | 2300 S CUSHMAN ST | DESK       | NRP   | 05/28/2019 16:48:20 |
|          | 05/26/2019 16:09 | DISTURBANCE -       | 2300 S CUSHMAN ST | O13        | NRP   | 05/26/2019 16:28:34 |
|          | 05/25/2019 18:01 | OFFICER ADVICE      | 2300 S CUSHMAN ST | O17        | NRP   | 05/25/2019 21:43:43 |
|          | 05/25/2019 14:26 | DUI - MOVING -      | 2300 S CUSHMAN ST | O7         | NRP   | 05/25/2019 14:46:38 |
|          | 05/20/2019 23:31 | TRESPASS/UNWANTE    | 2300 S CUSHMAN ST | S8         | NRP   | 05/20/2019 23:38:21 |
|          | 05/19/2019 22:30 | TRESPASS/UNWANTE    | 2300 S CUSHMAN ST | O5         | NRP   | 05/19/2019 22:40:17 |
| 19001487 | 05/16/2019 15:13 | SI - FOLLOW-UP      | 2300 S CUSHMAN ST | O2         | RPT   | 05/17/2019 13:24:55 |
|          | 05/14/2019 20:38 | AOA - NON URGENT -  | 2300 S CUSHMAN ST | O41        | NRP   | 05/14/2019 20:57:11 |
|          | 05/11/2019 19:21 | SUSPICIOUS VEHICLE  | 2300 S CUSHMAN ST | O19        | NRP   | 05/11/2019 19:50:18 |
| 19001655 | 05/10/2019 21:21 | MVC - NO INJURIES - | 2300 S CUSHMAN ST | O17        | RPT   | 05/11/2019 00:25:51 |
|          | 05/08/2019 20:52 | DISTURBANCE -       | 2300 S CUSHMAN ST | O4         | NRP   | 05/08/2019 22:53:53 |
| 19001615 | 05/08/2019 13:27 | ASSAULT CHARLIE -   | 2300 S CUSHMAN ST | O9         | RPT   | 05/08/2019 14:27:34 |
| 19001525 | 05/03/2019 19:16 | WEAPONS INCIDENT    | 2300 S CUSHMAN ST | O25        | RPT   | 05/03/2019 22:07:25 |
| 19001525 | 05/03/2019 18:14 | ASSAULT - DELTA     | 2300 S CUSHMAN ST | O19        | RPT   | 05/03/2019 21:36:06 |
| 19001501 | 05/03/2019 00:56 | SI - FIELD CONTACT  | 2300 S CUSHMAN ST | O21        | RPT   | 05/03/2019 02:42:47 |
|          | 04/30/2019 01:15 | DISTURBANCE -       | 2300 S CUSHMAN ST | O25        | NRP   | 04/30/2019 01:33:12 |
|          | 04/28/2019 00:29 | SI - SECURITY CHECK | 2300 S CUSHMAN ST | S5         | NRP   | 04/28/2019 00:32:37 |
|          | 04/26/2019 22:06 | SI - FIELD CONTACT  | 2300 S CUSHMAN ST | O13        | NRP   | 04/26/2019 22:35:02 |
|          | 04/18/2019 03:59 | DISTURBANCE -       | 2300 S CUSHMAN ST | O5         | NRP   | 04/18/2019 04:40:32 |
|          | 04/14/2019 01:37 | SI - SECURITY CHECK | 2300 S CUSHMAN ST | S5         | NRP   | 04/14/2019 01:48:25 |
|          | 04/11/2019 05:56 | TRESPASS/UNWANTE    | 2300 S CUSHMAN ST | O1         | NRP   | 04/11/2019 06:17:03 |
|          | 04/07/2019 07:08 | TRESPASS/UNWANTE    | 2300 S CUSHMAN ST | O3         | NRP   | 04/07/2019 07:40:54 |

| Report # | Call Time        | Nature           | Location          | Prime Unit | Disp. | Close Time          |
|----------|------------------|------------------|-------------------|------------|-------|---------------------|
|          | 04/02/2019 15:33 | ALARM            | 2300 S CUSHMAN ST | O1         | FAB   | 04/02/2019 15:44:57 |
|          | 03/26/2019 05:45 | DISTURBANCE -    | 2300 S CUSHMAN ST | O25        | NRP   | 03/26/2019 05:59:15 |
| 19000999 | 03/22/2019 23:59 | SI - FOLLOW-UP   | 2300 S CUSHMAN ST | O13        | RPT   | 03/23/2019 00:56:44 |
|          | 03/20/2019 00:55 | TRESPASS/UNWANTE | 2300 S CUSHMAN ST | O25        | NRP   | 03/20/2019 01:09:22 |

Total Number of Events Listed: **180**

# CITY OF FAIRBANKS PUBLIC SAFETY

## Event Report

Event ID: **2019-064478**

Call Ref #: 420

Date/Time Received: 06/23/19 00:21:38

Rpt #:

Prime S8

Services Involved

Call Source: PHONE

Unit: WERNER, NATHAN

|            |  |  |  |
|------------|--|--|--|
| <b>LAW</b> |  |  |  |
|------------|--|--|--|

Location: **2300 AIRPORT WAY**

(S) (N)TOWN

X-ST: *WILBUR ST*  
*PEGGER RD*

Jur: FB    Service: LAW    Agency: FPD  
St/Beat: BETW    District:    RA: RATW

Business: AK SALMON BAKE BUFFET

Phone:    GP: GP94

Nature: **FOUND PERSON - BRAVO**

Alarm Lvl: 1    Priority: 2

Medical Priority:

Reclassified Nature:

Caller: WINSOR, LAURA  
Addr:

Phone: (907)

Alarm:  
Alarm Type:

Vehicle #:    St:    Report Only: No    Race:    Sex:    Age:

Call Taker: 1199    Console: HAPY

Geo-Verified Addr.: Yes    Nature Summary Code: 123    Disposition: NRP    Close Comments:

Notes: UDTs: {S8} NO FURTHER 10-60`S [06/23/19 00:42:07 1249]  
{S8} FAMILY REUNITED [06/23/19 00:37:30 1249]  
C FOUND A 8YR BOY NAMED ... SHE IS AT THE SALMON BAKE WITH THE CHILD ATTEMPTING TO LOOK FOR  
MOM. [06/23/19 00:24:54 1199]  
Call Aborted:  
SEND [EPD] [06/23/19 00:24:19 1199]  
MOM DRIVES GRAY JEEP... CALLER IN PURPLE SHIRT AND BLK PANTS [06/23/19 00:23:46 1199]  
BLK SHIRT BLU SHORTS SANDLES AND LONG BOARD/ HELMET [06/23/19 00:23:11 1199]  
MOTHER... CALLER FOUND 9YR OLD NAME ... CALLER IS DISPATCHER WITH AIRPORT  
PD.... F [06/23/19 00:22:39 1199]  
I [06/23/19 00:22:03 1199]

### Times

|                                       | <u>Time From Call Received</u> |  |
|---------------------------------------|--------------------------------|--|
| Call Received: 06/23/19 00:21:38      |                                |  |
| Call Routed: 06/23/19 00:22:46        | 000:01:08                      | Unit Reaction: (1st Dispatch to 1st Arrive)    |
| Call Take Finished: 06/23/19 00:22:46 | 000:01:08                      | En-Route: (1st Dispatch to 1st En-Route)       |
| 1st Dispatch: 06/23/19 00:25:47       | 000:04:09 (Time Held)          | On-Scene: 000:18:39 (1st Arrive to Last Clear) |
| 1st En-Route: 06/23/19 00:25:47       | 000:04:09                      |  |
| 1st Arrive: 06/23/19 00:25:47         | 000:04:09 (Reaction Time)      |  |
| Last Clear: 06/23/19 00:44:26         | 000:22:48                      |  |

### Radio Log

| Unit | Empl ID | Type | Description | Time Stamp        | Comments              | Close Code | User |
|------|---------|------|-------------|-------------------|-----------------------|------------|------|
| S8   | 1155    | DXY  | DispatchXY  | 06/23/19 00:25:47 | 1361701.48,3965809.63 |            | 1249 |
| S8   | 1155    | D    | Dispatched  | 06/23/19 00:25:47 | Stat/Beat: COF        |            | 1249 |
| S8   | 1155    | E    | En-Route    | 06/23/19 00:25:47 | Stat/Beat: COF        |            | 1249 |
| S8   | 1155    | A    | Arrived     | 06/23/19 00:25:47 | Stat/Beat: COF        |            | 1249 |

|    |      |     |                       |                   |   |          |
|----|------|-----|-----------------------|-------------------|---|----------|
| S8 | 1155 | T   | Transport             | 06/23/19 00:27:55 | To: SALMON BAKE                           | 1249     |
| S8 | 1155 | A   | Arrived               | 06/23/19 00:35:26 |   | 1249     |
| S8 | 1155 | AAT | Auto Arrive Timestamp | 06/23/19 00:35:29 | Current status is:A. Offset of 0 seconds. | 1155     |
| S8 | 1155 | NO  | {S8} NO FURTHER 10-6  | 06/23/19 00:42:07 |   | 1249     |
| S8 | 1155 | C   | Cleared               | 06/23/19 00:44:26 |   | NRP 1155 |

|                  |
|------------------|
| <b>Event Log</b> |
|------------------|

| Unit | Empl ID | Type | Description          | Time Stamp        | Comments                             | Close Code | User |
|------|---------|------|----------------------|-------------------|--------------------------------------|------------|------|
|      |         | TR   | Time Received        | 06/23/19 00:21:38 | By: PHONE                            |            | 1199 |
|      |         | DLS  | Duplicate List       | 06/23/19 00:21:45 | Potential Duplicate Events Listed (2 |            | 1199 |
|      |         | ENT  | Entered Street       | 06/23/19 00:21:48 | 2300 AIRPORT WAY                     |            | 1199 |
|      |         | ENT  | Entered AddSt        | 06/23/19 00:21:48 | (S) (N)TOWN                          |            | 1199 |
|      |         | ENT  | Entered Remarks      | 06/23/19 00:22:03 |                                      |            | 1199 |
|      |         | ARM  | Added Remarks        | 06/23/19 00:22:39 |                                      |            | 1199 |
|      |         | ENT  | Entered Nature       | 06/23/19 00:22:45 | FOUND PERSON - BRAVO                 |            | 1199 |
|      |         | LPS  | Law Pri. Started     | 06/23/19 00:22:45 | Case Started                         |            | 1199 |
|      |         | FIN  | Finished Call Taking | 06/23/19 00:22:46 |                                      |            | 1199 |
|      |         | ARM  | Added Remarks        | 06/23/19 00:23:11 |                                      |            | 1199 |
|      |         | ARM  | Added Remarks        | 06/23/19 00:23:46 |                                      |            | 1199 |
|      |         | ENT  | Entered CallerName_C | 06/23/19 00:23:57 | WINSOR,LAURA                         |            | 1199 |
|      |         | ENT  | Entered CallerPhone  | 06/23/19 00:24:14 | 907                                  |            | 1199 |
|      |         | ARM  | Added Remarks        | 06/23/19 00:24:19 |                                      |            | 1199 |
|      |         | LPA  | Law Pri. Aborted     | 06/23/19 00:24:19 | Case Aborted                         |            | 1199 |
|      |         | ARM  | Added Remarks        | 06/23/19 00:24:54 |                                      |            | 1199 |
|      |         | ARM  | Added Remarks        | 06/23/19 00:37:30 |                                      |            | 1249 |
|      |         | ARM  | Added Remarks        | 06/23/19 00:42:07 |                                      |            | 1249 |
|      |         | RS   | Reset Watchdog Timer | 06/23/19 00:42:07 | Units: S8 >>> 30Min.                 |            | 1249 |

|                      |
|----------------------|
| <b>Related Names</b> |
|----------------------|

| Last, First, MI Suffix | Type | Race | Sex     | HT | WT | Eyes | DOB | Age | Home / Mobile Ph | Work Ph |
|------------------------|------|------|---------|----|----|------|-----|-----|------------------|---------|
| Winther, Laura         | CALL |      |         |    | 0  |      |     |     | (907)            |         |
| Address:               |      |      |         |    |    |      |     |     |                  |         |
| Oln:                   |      |      | Oln St: |    |    |      |     |     |                  |         |
| Notes:                 |      |      |         |    |    |      |     |     |                  |         |

**CITY OF FAIRBANKS PUBLIC SAFETY**

**Gallantino`s Italian Restaurant 1446 S. Cushman Street**

03/19/2019 - 03/17/2020

| <b>Report #</b> | <b>Call Time</b> | <b>Nature</b> | <b>Location</b>   | <b>Prime Unit</b> | <b>Disp.</b> | <b>Close Time</b>   |
|-----------------|------------------|---------------|-------------------|-------------------|--------------|---------------------|
|                 | 05/14/2019 07:05 | INCAPACITATED | 1452 S CUSHMAN ST | O9                | NRP          | 05/14/2019 08:18:13 |
|                 | 05/06/2019 14:45 | SI - ADMIN    | 1452 S CUSHMAN ST | S5                | NRP          | 05/06/2019 14:48:15 |

Total Number of Events Listed: **2**

# CITY OF FAIRBANKS PUBLIC SAFETY

Big Daddy's Bar-B-Q & Banquet Hall 107 Wickersham Street

03/19/2019 - 03/17/2020

| Report # | Call Time        | Nature             | Location          | Prime Unit | Disp. | Close Time          |
|----------|------------------|--------------------|-------------------|------------|-------|---------------------|
| 20000509 | 02/14/2020 13:46 | LOST PROPERTY -    | 107 WICKERSHAM ST | O15        | RPT   | 02/14/2020 14:01:43 |
|          | 02/09/2020 00:21 | ALARM BURGLARY -   | 107 WICKERSHAM ST | O34        | FAB   | 02/09/2020 00:39:20 |
|          | 11/28/2019 08:53 | ALARM BURGLARY -   | 107 WICKERSHAM ST | O7         | FAB   | 11/28/2019 09:01:41 |
|          | 10/18/2019 21:40 | DISTURBANCE        | 107 WICKERSHAM ST | O19        | NRP   | 10/18/2019 22:07:11 |
|          | 09/05/2019 14:07 | 10-36              | 107 WICKERSHAM ST | O19        | WAR   | 09/05/2019 14:19:55 |
|          | 08/15/2019 10:54 | DISTURBANCE        | 107 WICKERSHAM ST | O1         | NRP   | 08/15/2019 11:11:30 |
| 19002848 | 07/28/2019 07:01 | SI - FOLLOW-UP     | 107 WICKERSHAM ST | O1         | RPT   | 07/28/2019 10:31:31 |
| 19002848 | 07/28/2019 04:04 | PAST VEHICLE THEFT | 107 WICKERSHAM ST | O17        | RPT   | 07/28/2019 05:19:40 |

Total Number of Events Listed: 8

Incident / Event (Search) ✖

Include delayed

ONESolution CAD ✖

No match found.





# City of Fairbanks

Office of the City Clerk

800 Cushman Street

Fairbanks, AK 99701

(907)459-6715  
Fax (907)459-6710

## LIQUOR LICENSE RESPONSE FORM

TO:  FINANCE DEPARTMENT  
 FIRE DEPARTMENT  
 POLICE DEPARTMENT

DATE: March 13, 2020

FROM: CITY CLERK'S OFFICE

RE: LIQUOR LICENSE ACTION – RENEWALS

NOTICE RECEIVED AT CLERKS OFFICE: 03/06/20 – 03/13/20 (60 DAY DUE DATE 05/05/20)

DATE RESPONSE DUE: 04/07/2020 for City Council Meeting of 04/13/2020

| Lic. # | DBA                                | License Type                       | Licensee                                     | Phone        | Address                     |
|--------|------------------------------------|------------------------------------|--|--------------|-----------------------------|
| 4816   | Mayan Palace                       | Beverage Dispensary                | Taco Azteca, Inc.                            | 907-350-6047 | 3401 Airport Way            |
| 3151   | Fred Meyer 485                     | Package Store                      | Fred Meyer Stores, Inc.                      | 615-232-9776 | 3755 Airport Way            |
| 1059   | Raven Landing Center               | Beverage Dispensary                | Retirement Community of Fairbanks            | 907-378-3750 | 949 McGown Street           |
| 54     | American Legion Post 11            | Club                               | The American Legion, Dorman H Baker Post #11 | 907-322-6834 | 129 1st Avenue              |
| 5436   | Hoarfrost Distilling               | Distillery                         | Hoarfrost Distilling, LLC                    | 907-460-7918 | 3501 Lathrop Street, Unit F |
| 3170   | The Odom Corporation               | Wholesale – General                | The Odom Corporation                         | 425-456-3545 | 3401 Peger Road, Bay 1      |
| 4831   | Irashai Japanese Restaurant        | Restaurant/Eating Place            | 2GIRO, Inc.                                  | 213-200-3379 | 419 Merhar Avenue, Suite B  |
| 4156   | Holiday #622                       | Package Store                      | Holiday Alaska, LLC                          | 952-830-8700 | 2300 S. Cushman Street      |
| 1639   | Alaska Salmon Bake                 | Restaurant/Eating Place – Seasonal | Malemute, Inc.                               | 907-452-7274 | 2300 Airport Way            |
| 4720   | Gallantino's Italian Restaurant    | Beverage Dispensary                | Gallantino's, Inc.                           | 907-350-6047 | 1446 S. Cushman Street      |
| 4174   | Big Daddy's Bar-B-Q & Banquet Hall | Beverage Dispensary                | RTG, LLC                                     | 907-799-5598 | 107 Wickersham Street       |
| 5500   | K & L Distributors Alaska          | Wholesale – Malt Beverage & Wine   | White Mountain Beverage, LLC                 | 606-436-0736 | 945 Elizabeth Street        |

NO PROTEST:       PROTEST

REASONS OR COMMENTS: Protesting - Big Daddy's does not have a 2020 Business License.

DEPARTMENT  
SIGNEE:

Margarita Sue      04-06-2020  
SIGNATURE      DATE

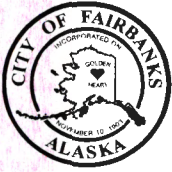

# City of Fairbanks

Office of the City Clerk

800 Cushman Street

Fairbanks, AK 99701

(907)459-6715  
Fax (907)459-6710

## LIQUOR LICENSE RESPONSE FORM

TO:  FINANCE DEPARTMENT  
 FIRE DEPARTMENT  
 POLICE DEPARTMENT

DATE: March 13, 2020

FROM: CITY CLERK'S OFFICE

RE: LIQUOR LICENSE ACTION – RENEWALS

NOTICE RECEIVED AT CLERKS OFFICE: 03/06/20 – 03/13/20 (60 DAY DUE DATE 05/05/20)

DATE RESPONSE DUE: **04/07/2020** for City Council Meeting of 04/13/2020

| Lic. # | DBA                                | License Type                       | Licensee                                     | Phone        | Address                     |
|--------|------------------------------------|------------------------------------|--|--------------|-----------------------------|
| 4816   | Mayan Palace                       | Beverage Dispensary                | Taco Azteca, Inc.                            | 907-350-6047 | 3401 Airport Way            |
| 3151   | Fred Meyer 485                     | Package Store                      | Fred Meyer Stores, Inc.                      | 615-232-9776 | 3755 Airport Way            |
| 1059   | Raven Landing Center               | Beverage Dispensary                | Retirement Community of Fairbanks            | 907-378-3750 | 949 McGown Street           |
| 54     | American Legion Post 11            | Club                               | The American Legion, Dorman H Baker Post #11 | 907-322-6834 | 129 1st Avenue              |
| 5436   | Hoarfrost Distilling               | Distillery                         | Hoarfrost Distilling, LLC                    | 907-460-7918 | 3501 Lathrop Street, Unit F |
| 3170   | The Odom Corporation               | Wholesale – General                | The Odom Corporation                         | 425-456-3545 | 3401 Peger Road, Bay 1      |
| 4831   | Irashai Japanese Restaurant        | Restaurant/Eating Place            | 2GIRO, Inc.                                  | 213-200-3379 | 419 Merhar Avenue, Suite B  |
| 4156   | Holiday #622                       | Package Store                      | Holiday Alaska, LLC                          | 952-830-8700 | 2300 S. Cushman Street      |
| 1639   | Alaska Salmon Bake                 | Restaurant/Eating Place – Seasonal | Malemute, Inc.                               | 907-452-7274 | 2300 Airport Way            |
| 4720   | Gallantino's Italian Restaurant    | Beverage Dispensary                | Gallantino's, Inc.                           | 907-350-6047 | 1446 S. Cushman Street      |
| 4174   | Big Daddy's Bar-B-Q & Banquet Hall | Beverage Dispensary                | RTG, LLC                                     | 907-799-5598 | 107 Wickersham Street       |
| 5500   | K & L Distributors Alaska          | Wholesale – Malt Beverage & Wine   | White Mountain Beverage, LLC                 | 606-436-0736 | 945 Elizabeth Street        |

NO PROTEST:       PROTEST

REASONS OR COMMENTS: Protest: American Legion Post 11 and Big Daddy's for incomplete inspection. All other: no protest

DEPARTMENT

SIGNEE:

*James N. Styers*

*James N. Styers*

# MEMORANDUM

City of Fairbanks Clerk's Office

D. Danyielle Snider, City Clerk

TO: Mayor Jim Matherly and City Council Members  
FROM: D. Danyielle Snider, CMC, City Clerk   
SUBJECT: Application for Liquor License Transfer – Controlling Interest  
DATE: April 7, 2020

An application has been received by the State Alcohol and Marijuana Control Office (AMCO) for transfer of controlling interest for the following liquor license applicant:

License Type: Beverage Dispensary, License #145  
DBA: **Boatel Bar**  
Licensee/Applicant: Abie Neubauer, Inc.  
Physical Location: 3368 Riverside Drive, Fairbanks AK

| Corp/LLC Agent:                       | Address                             | Phone        | Date/State of Incorporation | Good standing? |
|---------------------------------------|-------------------------------------|--------------|-----------------------------|----------------|
| Abie Neubauer, Inc.<br>Annie Neubauer | PO Box 80626<br>Fairbanks, AK 99708 | 907-452-5506 | 01/04/1982 – AK             | Yes            |

*Please note: the Members/Officers/Directors/Shareholders (principals) listed below are the principal members. There may be additional members that we are not aware of because they are not primary members. We have listed all principal members and those who hold at least 10% shares.*

| Entity Ownership:  | Address  | Phone        | Title/Shares (%)          |
|--------------------|--|--------------|---------------------------|
| Christine Neubauer | 1025 Southwood Lane<br>Fairbanks, AK 99712       | 907-378-5972 | Secretary/Treasurer – 45% |
| Natalie Neubauer   | 506 Wickersham Street, #B<br>Fairbanks, AK 99701 | 907-388-9256 | Vice President – 45%      |
| Annie Neubauer     | PO Box 80626<br>Fairbanks, AK 99708              | 907-452-5506 | President – 10%           |

This is a transfer of controlling interest only; currently Annie Neubauer is 100% shareholder.

Pursuant to FCG Sec. 14-178, the Council must determine whether to protest the liquor license action after holding a public hearing.

The Fairbanks Police Department (FPD) has submitted a call report for this location (see attached), but Chief Reeder is not recommending protest.

There are **no departmental objections** to the transfer of controlling interest for this license.



# CITY OF FAIRBANKS PUBLIC SAFETY

## The Boatel

04/04/2019 - 04/02/2020

| Report # | Call Time        | Nature             | Location          | Prime Unit | Disp. | Close Time          |
|----------|------------------|--------------------|-------------------|------------|-------|---------------------|
|          | 02/23/2020 01:56 | SI - BAR CHECK     | 3368 RIVERSIDE DR | O17        | NRP   | 02/23/2020 01:58:09 |
|          | 10/18/2019 02:34 | DISTURBANCE        | 3368 RIVERSIDE DR | O41        | NRP   | 10/18/2019 03:03:22 |
|          | 10/06/2019 13:19 | FOUND PROPERTY -   | 3368 RIVERSIDE DR | O22        | NRP   | 10/06/2019 13:46:55 |
|          | 10/06/2019 02:25 | 911 HANG-UP -      | 3368 RIVERSIDE DR | O5         | NRP   | 10/06/2019 02:30:36 |
|          | 08/31/2019 01:30 | SI - AOA           | 3368 RIVERSIDE DR | O16        | NRP   | 08/31/2019 01:39:55 |
| 19003255 | 08/24/2019 12:10 | SI - FOLLOW-UP     | 3368 RIVERSIDE DR | O2         | RPT   | 08/24/2019 14:20:56 |
|          | 08/17/2019 14:19 | AOA - NON URGENT - | 3368 RIVERSIDE DR | S11        | NRP   | 08/17/2019 14:48:37 |
|          | 08/17/2019 14:14 | AOA - NON URGENT - | 3368 RIVERSIDE DR | O2         | NRP   | 08/17/2019 14:35:06 |
|          | 08/11/2019 03:26 | DISTURBANCE        | 3368 RIVERSIDE DR | O17        | NRP   | 08/11/2019 03:46:44 |
|          | 08/04/2019 16:22 | SI - BAR CHECK     | 3368 RIVERSIDE DR | O9         | NRP   | 08/04/2019 16:29:07 |
|          | 08/04/2019 16:14 | SI - FIELD CONTACT | 3368 RIVERSIDE DR | L4         | NRP   | 08/04/2019 16:25:59 |
|          | 07/27/2019 00:31 | REDDI              | 3368 RIVERSIDE DR | DESK       | NRP   | 07/27/2019 02:13:31 |
|          | 07/04/2019 00:50 | DISTURBANCE        | 3368 RIVERSIDE DR | S9         | NRP   | 07/04/2019 01:16:39 |
|          | 06/24/2019 22:44 | DISTURBANCE -      | 3368 RIVERSIDE DR | O32        | NRP   | 06/24/2019 22:54:03 |
|          | 06/19/2019 15:16 | PAST HIT & RUN -   | 3368 RIVERSIDE DR | DESK       | NRP   | 06/19/2019 15:28:37 |
|          | 06/16/2019 00:13 | NUISANCE - BRAVO   | 3368 RIVERSIDE DR | S8         | NRP   | 06/16/2019 00:31:23 |
|          | 06/15/2019 23:13 | PAST DISTURBANCE - | 3368 RIVERSIDE DR | O5         | NRP   | 06/15/2019 23:56:42 |
|          | 05/18/2019 14:35 | AOA - NON URGENT - | 3368 RIVERSIDE DR | O1         | NRP   | 05/18/2019 14:38:11 |
| 19001777 | 05/18/2019 02:26 | DISTURBANCE -      | 3368 RIVERSIDE DR | O34        | RPT   | 05/18/2019 03:57:48 |

Total Number of Events Listed: **19**



# MEMORANDUM

City of Fairbanks Clerk's Office

D. Danyielle Snider, City Clerk

---

TO: Mayor Jim Matherly and City Council Members  
FROM: D. Danyielle Snider, CMC, City Clerk   
SUBJECT: Application for New Retail Marijuana Store License  
DATE: April 7, 2020

---

Attached you will find a notification from the Alcohol and Marijuana Control Office (AMCO) of an application for a new Retail Marijuana Store License and additional information for the following applicant:

License #: **22809**  
License Type: **Retail Marijuana Store**  
D.B.A.: Airport Way Best Bud  
Licensee/Applicant: Airport Way Trade Center, LLC  
Physical Location: 3598 Airport Way, Fairbanks, Alaska

Pursuant to FGC Sec. 14-214 and 3 AAC 306.060, the Council must determine whether to protest the marijuana license application after holding a public hearing.

A notice of the date, time, and place of the public hearing has been mailed to all property owners within 1,000 feet of the proposed retail marijuana store, and notice of the public hearing will be advertised in the Fairbanks Daily News Miner on Friday, April 10, 2020.

The the Police Department has included a one-year call report for the location, but Chief Reeder is not recommending protest. There are **no departmental objections** to the issuance of the license.

**CITY OF FAIRBANKS PUBLIC SAFETY**

**Airport Way Best Bud 3598 Airport Way**

04/04/2019 - 04/02/2020

| <b>Report #</b> | <b>Call Time</b> | <b>Nature</b> | <b>Location</b>  | <b>Prime Unit</b> | <b>Disp.</b> | <b>Close Time</b>   |
|-----------------|------------------|---------------|------------------|-------------------|--------------|---------------------|
|                 | 11/02/2019 03:38 | DISTURBANCE   | 3598 AIRPORT WAY | S3                | NRP          | 11/02/2019 03:45:31 |
| 19004203        | 11/02/2019 00:32 | DISTURBANCE   | 3598 AIRPORT WAY | O2                | RPT          | 11/02/2019 01:17:39 |
|                 | 05/08/2019 15:27 | DISTURBANCE - | 3598 AIRPORT WAY | O9                | NRP          | 05/08/2019 15:39:18 |

Total Number of Events Listed: **3**

# Alcohol & Marijuana Control Office

**License Number:** 22809

**License Status:** New

**License Type:** Retail Marijuana Store

**Doing Business As:** Airport Way Best Bud

**Business License Number:** 2091749

**Designated Licensee:** Richard Barnes

**Email Address:** richbarnes21@gmail.com

**Local Government:** Fairbanks (City of)

**Community Council:**

**Latitude, Longitude:** 64.837573, -147.811379

**Physical Address:** 3598 Airport Way  
Fairbanks, AK 99709  
UNITED STATES

## Licensee #1

**Type:** Entity

**Alaska Entity Number:** 10111581

**Alaska Entity Name:** Airport Way Trade Center LLC

**Phone Number:** 907-888-3366

**Email Address:** richbarnes21@gmail.com

**Mailing Address:** PO Box 71640  
Fairbanks, AK 99707-1640  
UNITED STATES

## Entity Official #1

**Type:** Individual

**Name:** Richard Barnes

**SSN:** [REDACTED]

**Date of Birth:** [REDACTED]

**Phone Number:** 907-888-3366

**Email Address:** richbarnes21@gmail.com

**Mailing Address:** PO Box 71640  
Fairbanks, AK 99707-1640  
UNITED STATES

**Note:** No affiliates entered for this license.



## Alaska Marijuana Control Board Operating Plan Supplemental Form MJ-03: Retail Marijuana Store

### What is this form?

This operating plan supplemental form is required for all applicants seeking a retail marijuana store license and must accompany **Form MJ-01: Marijuana Establishment Operating Plan**, per 3 AAC 306.020(b)(11). Applicants should review **Chapter 306: Article 3** of the **Alaska Administrative Code**. This form will be used to document how an applicant intends to meet the requirements of the statutes and regulations.

If your business has a formal operating plan, you may include a copy of that operating plan with your application, but all fields of this form must still be completed per 3 AAC 306.020 and 3 AAC 306.315(2).

### What additional information is required for retail stores?

Applicants must identify how the proposed establishment will comply with applicable regulations regarding the following:

- Prohibitions
- Signage and advertising
- Displays and sales
- Exit packaging and labeling
- Security
- Waste disposal

**This form must be completed and submitted to AMCO's main office before any new or transfer application for a retail marijuana store license will be considered complete.**

### Section 1 – Establishment Information

Enter information for the business seeking to be licensed, as identified on the license application.

|                    |                              |               |        |      |       |
|--------------------|------------------------------|---------------|--------|------|-------|
| Licensee:          | Airport Way Trade Center LLC | MJ License #: | 22809  |      |       |
| License Type:      | Retail Marijuana Store       |               |        |      |       |
| Doing Business As: | Airport Way Best Bud         |               |        |      |       |
| Premises Address:  | 3598 Airport Way             |               |        |      |       |
| City:              | Fairbanks                    | State:        | Alaska | ZIP: | 99709 |

AMCO

JAN 10 2020





# Form MJ-03: Retail Marijuana Store Operating Plan Supplemental

## Section 2 – Overview of Operations

2.1. Provide an overview of your proposed facility's operations. Include information regarding the intake and flow of marijuana and marijuana product at your premises, and a description of what a standard customer visit to your establishment would entail:

When an incoming transfer of marijuana or marijuana product arrives at our facility, the transfer agent will be greeted and have their marijuana handler permit (MHP) checked by staff before being granted access to the facility. All transfers and verifications shall occur in the secure portion of our facility. All visitors, including other licensees and transfer agents, will be logged in our visitor log and will be issued a visitors badge to wear prior to being granted access to enter the secure portion of the facility. Every incoming transfer will be verified against the manifest; ensuring package tags are with product and match product, and that the quantities and weights manifested are accurate. Once weights, quantities, and package tags have been verified, the manifest will be signed and dated by the receiving manager on duty and the time of acceptance will be noted on the hard copy of the manifest and the transfer will be accepted in METRC. If any variance should exist between the manifested quantity and the actual quantity, every effort will be made to reach the licensee before accepting or rejecting any transfer. Incoming marijuana or marijuana products received in bulk will be repacked physically and within METRC and will accordingly be labeled before imported into our POS system and becoming available for sale. SEE CONT'D RESPONSE PG 6

## Section 3 – Prohibitions

Review the requirements under 3 AAC 306.310.

3.1. Describe how you will ensure that the retail marijuana store will not sell, give, distribute, or deliver marijuana or marijuana product to a person who is under the influence of an alcoholic beverage, inhalant, or controlled substance:

All staff at Airport Way Best Bud will be privately trained annually and prior to hire in preventing purchase by intoxicated persons under the influence of alcohol, inhalants, controlled substances as well as spice and or other designer/synthetic drugs. In addition, all employees will have completed the state required marijuana handlers course, and passed the written examination in order to receive their current handlers permit (MHP), renewals shall be required and verified. SEE CONT'D RESPONSE PG 6

3.2. I certify that the retail marijuana store will not:

Initials

- a. sell, give, distribute, deliver, or offer to sell, give, distribute, or deliver marijuana or marijuana product in a quantity exceeding the limit set out in 3 AAC 306.355;
- b. sell, give, distribute, deliver, or offer to sell, give, distribute, or deliver marijuana or marijuana product over the internet;
- c. offer or deliver to a consumer, as a marketing promotion or for any other reason, free marijuana or marijuana product, including a sample;
- d. offer or deliver to a consumer, as a marketing promotion or for any other reason, alcoholic beverages, free or for compensation; or
- e. allow a person to consume marijuana or a marijuana product on the licensed premises.

RB  
RB  
RB  
RB  
RB

AMCO  
JAN 10 2020

Answer "Yes" or "No" to the following question:

Yes No

3.3. Do you plan to request future approval of the Marijuana Control Board to permit consumption of marijuana or marijuana product in a designated area on the proposed premises?





# Form MJ-03: Retail Marijuana Store Operating Plan Supplemental

## Section 4 – Signage and Advertising

Review the requirements under 3 AAC 306.360 and 3 AAC 306.365. All licensed retail marijuana stores must meet minimum standards for signage and advertising.

You must be able to certify each statement below. Read the following and then sign your initials in the corresponding box: Initials

4.1. I understand and agree to follow the limitations regarding the number, placement, and size of signs on my proposed establishment, set forth in 3 AAC 306.360(a).

RB

4.2. The retail marijuana store will not use giveaway coupons as promotional materials, or conduct promotional activities such as games or competitions to encourage the sale of marijuana or marijuana products.

RB

4.3. All advertising for marijuana or marijuana product will contain the warnings required under 3 AAC 306.360(e).

RB

4.4. I understand and agree to post, in a conspicuous location visible to customers, the notification signs required under 3 AAC 306.365.

RB

4.5. I certify that no advertisement for marijuana or marijuana product will contain any statement or illustration that:

a. is false or misleading;

RB

b. promotes excessive consumption;

RB

c. represents that the use of marijuana has curative or therapeutic effects;

RB

d. depicts a person under the age of 21 consuming marijuana; or

RB

e. includes an object or character, including a toy, a cartoon character, or any other depiction designed to appeal to a child or other person under the age of 21, that promotes consumption of marijuana.

RB

4.6. I certify that no advertisement for marijuana or marijuana product will be placed:

a. within 1,000 feet of the perimeter of any child-centered facility, including a school, childcare facility, or other facility providing services to children, a playground or recreation center, a public park, a library, or a game arcade that is open to persons under the age of 21;

RB

b. on or in a public transit vehicle or public transit shelter;

RB

c. on or in a publicly owned or operated property;

RB

d. within 1,000 feet of a substance abuse or treatment facility; or

RB

e. on a campus for postsecondary education.

RB

AMCO

JAN 10 2020

## Section 5 – Displays and Sales

5.1. Describe how marijuana and marijuana products at the retail marijuana store will be displayed and sold:

Marijuana Products at our facility will be displayed; A) Hanging on slat wall behind counters in restricted access area, and or B) In secured glass cases which only authorized personnel can access. Customers will not have free access to such display cases. No product is to be touched by anyone other than staff prior to sale. Customers, after having had ID verified and being buzzed into retail area will consult our retail staff as to which products they intend on purchasing, no customers shall be left unattended in retail area of store. All purchases will be done at designated point of sale (POS) system. Once payment is recieved the customer will be provided with their packaged, labelled product(s) and may exit the building. All products in that purchase will have labelling provided by either the originating licensed cultivation company or Airport Way Best Bud. The label will include the logo, store name, license number, THC levels (provided by licensed testing facility) and all warning statements required under 3 AAC 306.345. MAX 5 CUSTOMERS PER EMPLOYEE

ON DUTY



**Section 6 – Exit Packaging and Labeling**

Review the requirements under 3 AAC 306.345.

6.1. Describe how the retail marijuana store will ensure that marijuana and marijuana products sold on its licensed premises will meet the packaging and labeling requirements set forth in 3 AAC 306.345(a):

Marijuana product will be packaged in opaque, resealable, child resistant packaging as described in 3 AAC 306.345(a). Any and all products to be sold will comply with; 3 AAC 306.470, 3 AAC 306.475, 3 AAC 306.570 and 3 AAC 306.345(b). Upon receipt of any marijuana from a licensed cultivation facility, staff will be required to inspect such packaging to verify the labeling requirements described in 3 AAC 306.475(a) and 3 AAC 306.570(c). Staff shall also verify labeling information to ensure packaging and potency conforms to regulations set forth in 3 AAC 306.560. Airport Way Best Bud will utilize registered weight measuring scales in compliance with 3 AAC 306.745 and AS 45.75.080 to verify weights of product. Packaging to be resold from a cultivation facility without additional handling from our facility will not be in excess of one ounce in weight and will contain our company logo and license number. Wholesale purchases will be verified to not be in excess of five pounds of product for repacking.

6.2. Provide a sample label that the retail marijuana store will use to meet the labeling requirements set forth in 3 AAC 306.345(b):

**Response to Question 6.2: Sample Label**

- (1) "Marijuana has intoxicating effects and may be habit forming and addictive.";
- (2) "Marijuana impairs concentration, coordination, and judgment.  
Do not operate a vehicle or machinery under its influence.";
- (3) "There are health risks associated with consumption of marijuana.";
- (4) "For use only by adults twenty-one and older. Keep out of the reach of children.";
- (5) "Marijuana should not be used by women who are pregnant or breast feeding."

(AWBB LOGO HERE)

**Retailer: Airport Way Best Bud**  
**Retailer License No. 22809**

**OG KUSH BUD 1.0 Grams**  
**Harvest Batch No. A123456**

**BARCODE: (PRINTED HERE)**  
**Cultivator: Some Alaska Grower LLC**  
**Cultivator License No. AK12345**

**Net Wt: 1.0gram (0.03527396 OZ.)**  
**Test: THCA:18.48%, THC 16.6%, CBD: .06%**  
**METRC ID#: 1A1234567890**





# Form MJ-03: Retail Marijuana Store Operating Plan Supplemental

## Section 7 – Security

Review the requirements under 3 AAC 306.350 and 3 AAC 306.720.

**7.1. Describe the retail marijuana store's procedures for ensuring a form of valid photographic identification has been produced before selling marijuana or marijuana product to a person, as required by 3 AAC 306.350(a):**

All Airport Way Best Bud (hereafter AWBB) employees will be trained in the recognition of valid and acceptable identification per SOA regulations governing acceptable forms of identification. See 3 AAC 306.350(a)&(b). Employees will take the following steps to ensure valid identification has been produced prior to any entry into retail store as follows: Make certain ID has not expired and person is over 21 years of age; request ID be removed from wallet or purse or anything with a cover over it; take physical control of the ID; check the date of birth; ensure ID has not been tampered with or altered; look for any material changes to ID. SEE CONT'D RESPONSE on pg. 6

You must be able to certify the statement below. Read the following and then sign your initials in the box to the right:

Initials

**7.2. The video surveillance and camera recording system for the licensed premises covers each point-of-sale area.**

RB

## Section 8 – Waste Disposal

Review the requirements under 3 AAC 306.740.

**8.1. Describe how you will store, manage, and dispose of any marijuana waste, including expired marijuana or marijuana products, in compliance with any applicable laws. Include details about the material(s) you will mix with ground marijuana waste and the processes that you will use to make the marijuana waste unusable for any purpose for which it was grown or produced:**

Prior to deeming marijuana as waste, we will notify AMCO 3 days in advance in writing. Once the MCB has been notified, product awaiting disposal will be separated and stored in our secure waste storage area. Our secure waste storage is secured and monitored in compliance with 3 AAC 306.715 and 3 AAC 306.720, utilizing commercial steel doors with key code locking mechanisms and high def surveillance cameras. Upon approval, any marijuana waste, including expired marijuana products will be ground and mixed with organic material consisting of household waste, paper, food, coffee grounds, leaves, grass clippings etc. to produce a final waste product that is no more than 50% marijuana product. Once marijuana product is reconciled to be unusable for any and all intended purposes, we will transfer the waste to our onsite secured dumpster to await final disposal. Upon final disposal, we will record the final destination of the waste, pursuant to 3 AAC 306.740(c) (2) and store these records in our secure office in compliance with 3 AAC 306.755

You must be able to certify the statement below. Read the following and then sign your initials in the box to the right:

Initials

**8.2. The retail marijuana store shall give the board at least three days written notice required under 3 AAC 306.740(c) before making marijuana waste unusable and disposing of it.**

RB

AMCO

JAN 10 2020

I declare under penalty of unsworn falsification that this form, including all accompanying schedules and statements, is true, correct, and complete.

Signature of licensee

RICHARD BARNES

Printed name of licensee

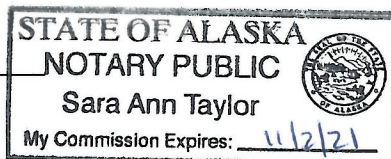

Notary Public in and for the State of Alaska  
My commission expires: 11/2/2021

Subscribed and sworn to before me this 1st day of JANUARY, 2020.





(Additional Space as Needed):

**2.1 RESPONSE CONT'D**

Each time a bulk package is opened or repackaged, weights will be taken at the beginning and end of the process. Internal logs will be kept and variance(s) due to moisture loss will be kept in the log; adjusted, noted, and accounted for in METRC. Any waste will be noted in waste logs as well, and reported to AMCO via email three days before destroying and disposing of the waste material. Unpackaged quantities of bulk marijuana or mj product will remain locked in secure storage, consistent with our plan and our published policy + procedure (s). METRC package tags will remain physically attached to the vessel containing bulk marijuana associated with each tag. Incoming marijuana or mj product which has been prepackaged prior to it's arrival at our facility will have the labeling double checked for compliance before being made available for retail sale. Product will then be added to inventory within the point of sale system, and may have additional, POS specific labeling/sku added. Upon entering the establishment, a customer will immediately be asked to produce ID. Once their ID has been verified the customer will be "buzzed" into the retail area and they will select product from our menu, be given an opportunity to view the product before purchasing (staff will remain in control of product until it is paid for thru POS system). Product(s) will be placed in AMCO compliant exit packaging before leaving the facility. All sales will be entered through our point of sale (POS) system, and will be reported through METRC daily.

Each drawer will be closed at the end of each shift and the proceeds from each shift and day will be verified against accountability reports generated by our POS system. At the end of each day, that day will be closed out within the POS system. Within 24 hours of closure of a business day, our sales data will be uploaded to METRC. Routine internal audits will be conducted by licensee or manager; verifying accuracy between METRC, our POS and product on hand. Inventory of prepackaged products will occur each night at the close of the shift and/or each morning before opening on internal forms (shift report/turnover). Retail operations are anticipated to begin at 8:00am until as late as 1:00am Monday thru Saturday. Sunday Open 11:00am thru closing at 9:00pm.

**3.1 RESPONSE CONT'D**

Employees will look for signs of Impairment to include but not limited to:

- watery eyes, - slurred speech, - blood shot or red eyes, - glassy eyes which may have trouble staying open, - their gait and - coordination (lack of). This list is not exhaustive. If any of the above signs or any others are identified the individual will be asked to leave the premisis and no sale will occur. This facility implements and enforces a zero tolerance policy for non-compliant behavior on our licensed premisis (including our parking area). Our policy requires that all personnel be trained on how to identify a person who is under the influence of an alcoholic beverage, inhalant, or controlled substance as set forth above. Any person(s) who are suspected of being in violation of 3 AAC 306.310(a)(2) will be asked (professionally) to vacate the premisis, they will be advised that non compliance will result in possible trespassing charges and if neccesary local law enforcement will be contactcted.

**7.1 RESPONSE CONT'D**

AWBB traing materials (reference at counter) shall include color sample photos of ALL STATE (s) ID's to include Canadian Provincial ID's should any questions arise surrounding it's authenticity. If questions surround ID authenticity, age verification or document validity the person will not be admitted into the premisis and shall be asked to leave or return with a valid verifiable form of ID.

AMCO

JAN 1 0 2020





## Alaska Marijuana Control Board Form MJ-02: Premises Diagram

### What is this form?

A detailed diagram of the proposed licensed premises is required for all marijuana establishment license applications, per 3 AAC 306.020(b)(8). **All areas designated as the licensed premises of a single license must be contiguous. All diagrams must have the licensed premises area labeled, and outlined or shaded as appropriate.**

### What must be submitted with this form?

Applicants must attach multiple diagrams to this form, including (as applicable):

- **Diagram 1:**  
a diagram showing only the licensed premises areas that will be ready to be **operational at the time of your preliminary inspection** and license issuance;
- **Diagram 2:**  
if different than Diagram 1, a diagram outlining **all areas for which the licensee has legal right of possession** (a valid lease or deed), and clearly showing those areas' relationship to the current proposed licensed premises (*details of any planned expansion areas do not need to be included; a complete copy of Form MJ-14: Licensed Premises Diagram Change must be submitted and approved before any planned expansion area may be added to the licensed premises*);
- **Diagram 3:**  
a **site plan or as-built of the entire lot**, showing all structures on the property and clearly indicating which area(s) will be part of the licensed premises;
- **Diagram 4:**  
an **aerial photo of the entire lot and surrounding lots**, showing a view of the entire property and surrounding properties, and clearly indicating which area(s) will be part of the licensed premises (*this can be obtained from sources like Google Earth*); and
- **Diagram 5:**  
a diagram of the **entire building in which the licensed premises is located**, clearly distinguishing the licensed premises from unlicensed areas and/or premises of other licenses within the building. If your proposed licensed premises is located within a building or building complex that contains multiple business and/or tenants, please provide the addresses and/or suite numbers of the other businesses and/or tenants (*a separate diagram is not required for an establishment that is designating the entire building as a single licensed premises*).

**This form, and all necessary diagrams that meet the requirements on Page 2 of this form, must be completed and submitted to AMCO's main office before any new or transfer license application will be considered complete.**

### Section 1 – Establishment Information

Enter information for the business seeking to be licensed, as identified on the license application.

|                    |                              |               |        |      |       |
|--------------------|------------------------------|---------------|--------|------|-------|
| Licensee:          | Airport Way Trade Center LLC | MJ License #: | 22809  |      |       |
| License Type:      | Retail Marijuana Store       |               |        |      |       |
| Doing Business As: | Airport Way Best Bud         |               |        |      |       |
| Premises Address:  | 3598 Airport Way             |               |        |      |       |
| City:              | Fairbanks                    | State:        | Alaska | ZIP: | 99709 |

AMCO





Alaska Marijuana Control Board  
**Form MJ-02: Premises Diagram**

**Section 2 – Required Information**

For your security, do not include locations of security cameras, motion detectors, panic buttons, and other security devices. Items marked with a double asterisks (\*\*) are only required for those retail marijuana establishments that are also applying for an onsite consumption endorsement.

The following details must be included in all diagrams:

- License number and DBA
- Legend or key
- Color coding
- Licensed Premises Area Labeled and Shaded, or Outlined as appropriate
- Dimensions
- Labels
- True north arrow

The following additional details must be included in Diagram 1:

- Surveillance room
- Restricted access areas
- Storage areas
- Entrances, exits, and windows
- Walls, partitions, and counters
- Any other areas that must be labeled for specific license or endorsement types
- \*\* Serving area(s)
- \*\*Employee monitoring area(s)
- \*\*Ventilation exhaust points, if applicable

The following additional details must be included in Diagram 2:

- Areas of ingress and egress
- Entrances and exits
- Walls and partitions

The following additional details must be included in Diagrams 3 and 4:

- Areas of ingress and egress
- Cross streets and points of reference

The following additional details must be included in Diagram 5:

- Areas of ingress and egress
- Entrances and exits
- Walls and partitions
- Cross streets and points of reference

AMCO  
 JAN 1 2020

I declare under penalty of unsworn falsification that I have attached all necessary diagrams that meet the above requirements, and that this form, including all accompanying schedules, statements, and depictions is true, correct, and complete.

Richard Barnes  
 Signature of licensee

RICHARD BARNES  
 Printed name of licensee

STATE OF ALASKA  
 NOTARY PUBLIC  
 Sara Ann Taylor  
 My Commission Expires: 11/2/21

Sara Ann Taylor  
 Notary Public in and for the State of Alaska

My commission expires: 11/2/21

Subscribed and sworn to before me this 9<sup>th</sup> day of December 2, 2019.



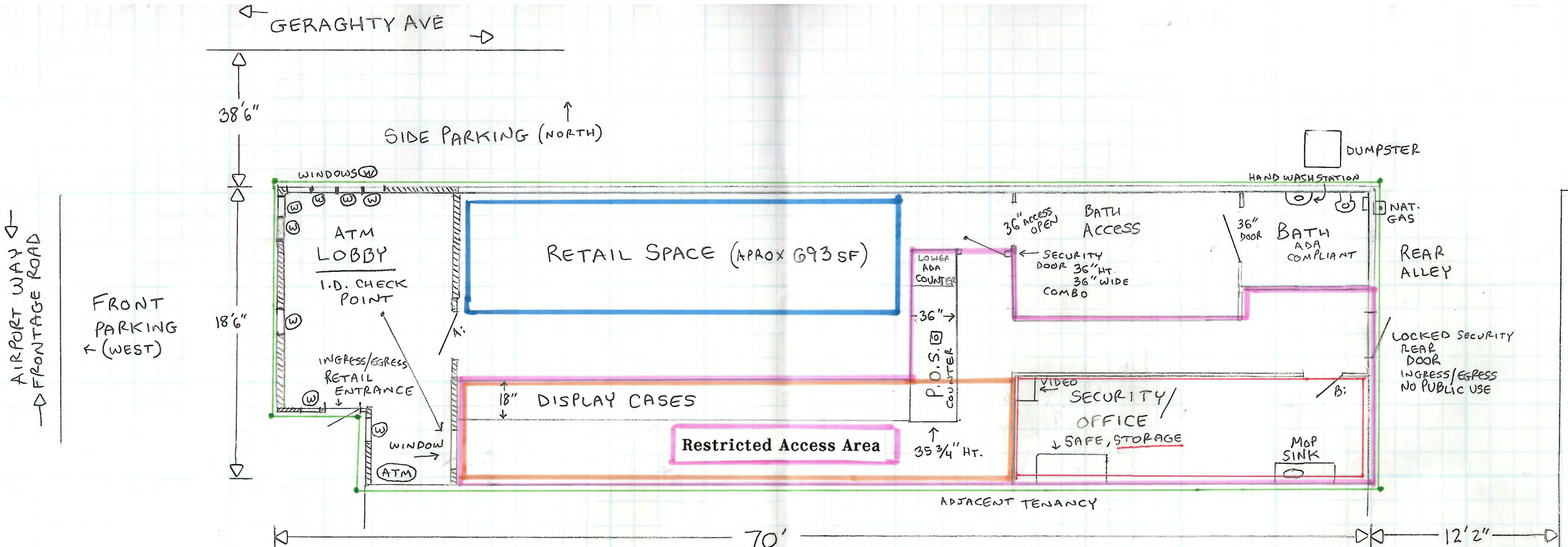

A: 36" STEEL SECURITY DOOR  
ELECTRONIC CONTROL  
⊗ CONTROLS LOCKED

B: 36" STEEL SECURITY DOOR LOCKED

**AMCO KEY**

- LICENSED LAWFUL RIGHT TO POSSESSION + PROPOSED LICENSED PREMISES
- RESTRICTED ACCESS AREA
- SHELVING DISPLAY WITH MARIJUANA
- SHELVING DISPLAY NO MARIJUANA
- MARIJUANA STORAGE

DIAGRAM 1/2

AMCO  
JAN 1 0 2020

|   |   |
|---|---|
| <p><b>Airport Way Best Bud – Retail Marijuana Store AMCO #22809</b></p> <p><b>Latitude/Longitude: 64.837573 -147.811379</b></p> | <p>AIRPORT WAY TRADE CENTER LLC<br/>AK ENTITY: 10111581</p> <p>DRAWN BY: R. BARNES<br/>DATE : 17 OCT 19</p> |
|---|---|

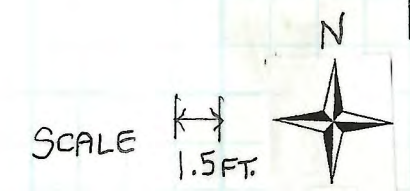



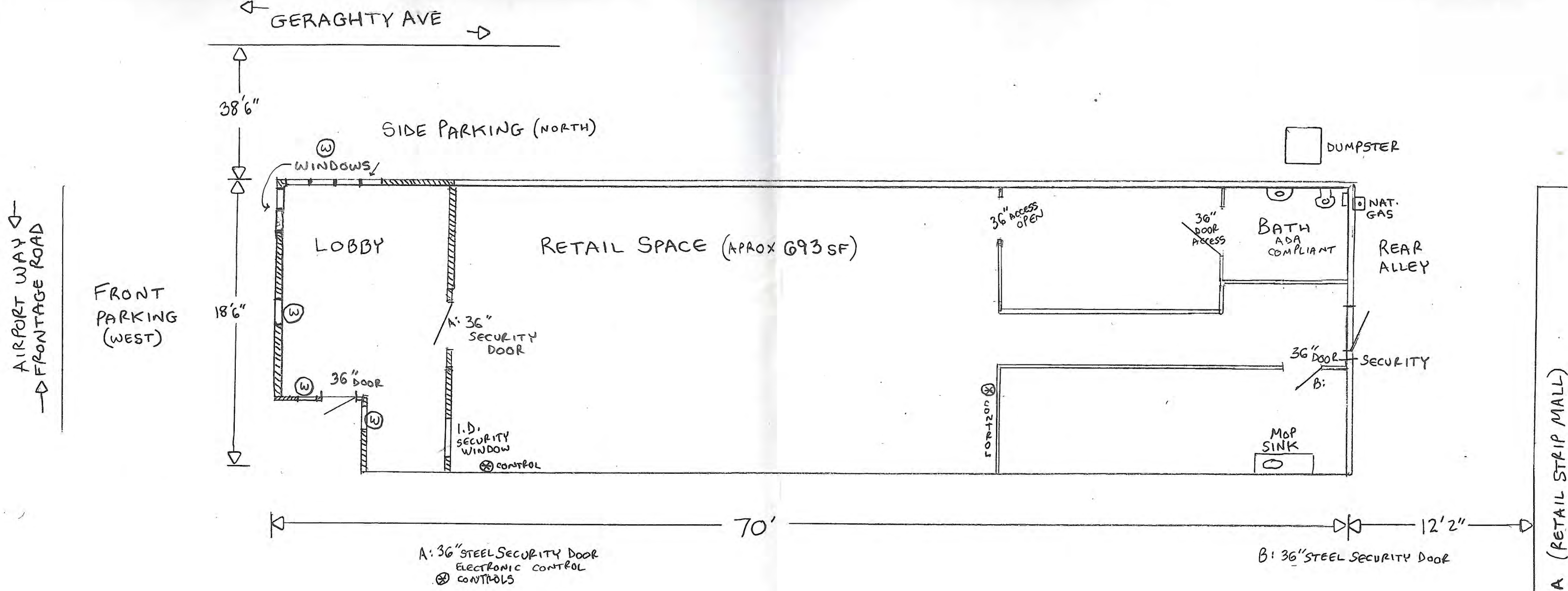
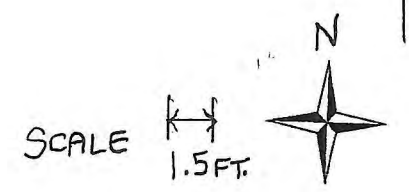

DIAGRAM 1B

WALLS + ENTRANCES + WINDOWS  
(BEFORE COLOR CODING)

AMCO  
JAN 10 2020

|   |   |
|---|---|
| <p>Airport Way Best Bud - Retail Marijuana Store AMCO #22809</p> <p>Latitude/Longitude: 64.837573 -147.811379</p> | <p>AIRPORT WAY TRADE CENTER LLC<br/>AK ENTITY: 10111581</p> <p>DRAWN BY: R. BARNES<br/>DATE : 17 OCT 19</p> |
|---|---|





# Fairbanks North Star Borough

PAN# 0525227

All Data Report LOT 1: PARKING, NO STRUCTURE

Printed on: 09/13/2019

LOT 2: SINGLE STRUCTURE, STRIP MALL (6 UNIT)

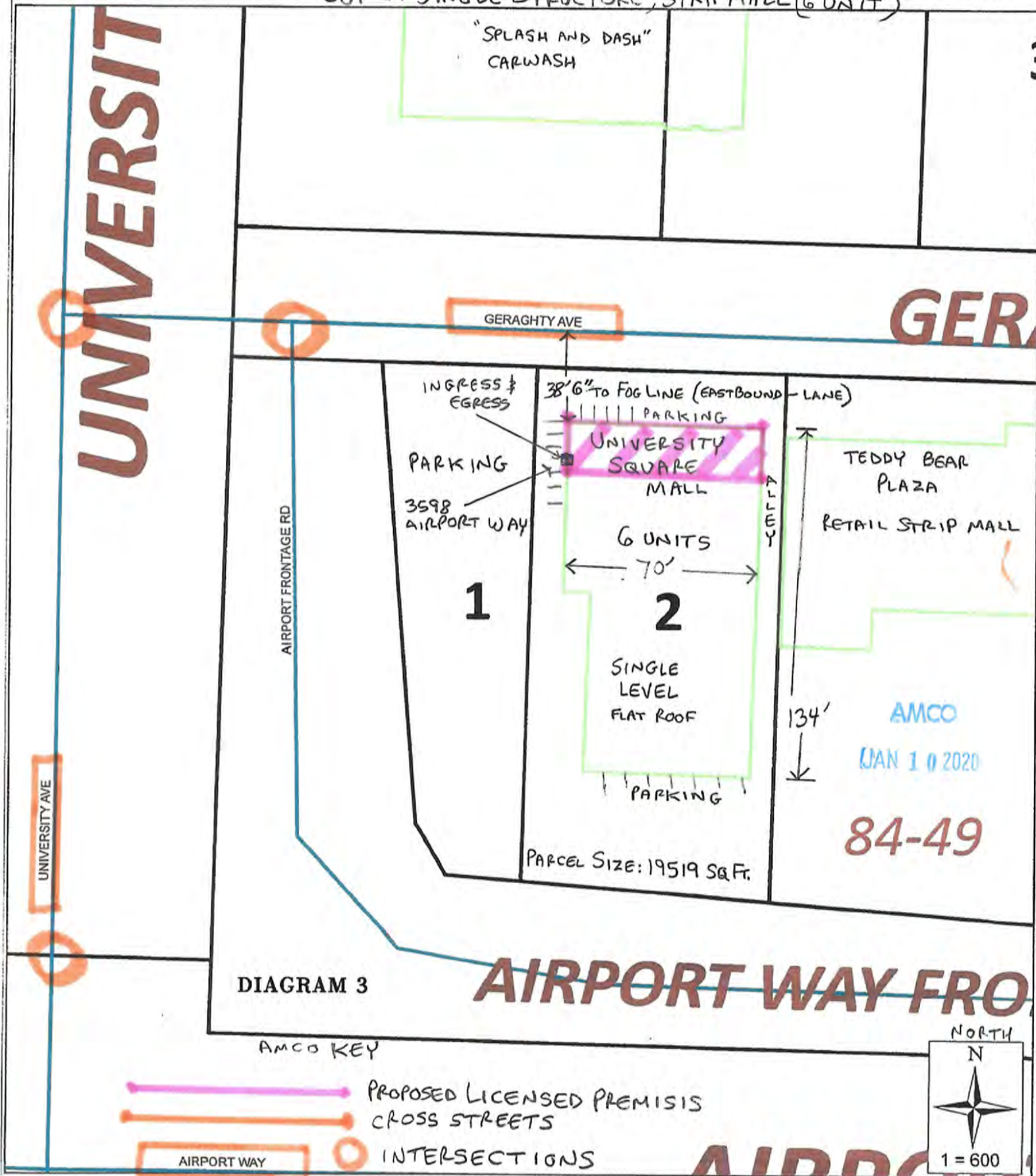
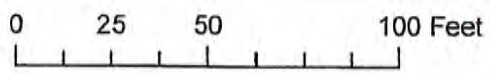

DIAGRAM 3

AMCO KEY

- PROPOSED LICENSED PREMISIS
- CROSS STREETS
- INTERSECTIONS



The Fairbanks North Star Borough does not warrant the accuracy of maps or data provided, nor their suitability for any particular application. There may be errors in the data.





# Fairbanks North Star Borough

All Data Report

PAN# 0525227

Printed on: 09/13/2019



Image courtesy of: Dicometry

**Property Information for PAN#: 0525227**

STATUS: ACTIVE - ROLL TYPE 1  
 PROPERTY DESCRIPTION: FAIRWEST NORTH, BLOCK: 05, LOT: 02  
 OWNER: Maynard Edward A [ownership]  
 BILLING ADDRESS: PO BOX 82527 Fairbanks, AK 99708 2527  
 SITUS ADDRESS: 3596 Airport Way, 3598 Airport Way, 3588 Airport Way, 3590 Airport Way, 3594 Airport Way, 3592 Airport Way  
 PARCEL SIZE: 19519 SF  
 NEIGHBORHOOD: Taku-Westgate (0145)  
 LAND CLASS: Assembled/See Umbrella  
 PRIMARY USE: Commercial  
 FLOOD ZONE: X: PROTECTED BY LEVEE (100%)  
 SPECIAL REG. AREAS: None  
 ZONING: GC (100%)  
 COMP PLAN: Urban Preferred Commercial Area (100%), Urban Boundary (100%)  
 PLANNING DISTRICT: Fairbanks (100%)  
 ROAD DISTRICT: N/A  
 URBAN BOUNDARY (2003): YES  
 ROAD SERVICE AREA: City of Fairbanks (100%)  
 FIRE SERVICE AREA: City of Fairbanks (100%)  
 FIRE SERVICE (Property DB): City of Fairbanks  
 STRUCTURES: N/A  
 BUSINESS ON SITE: N/A  
 MILL GROUP: Fairwest (0040) (Est. Mill Rate: 17.113)  
 PLAT NUMBER: FAIRWEST NORTH (FRD1962\_8600\_001)  
 DESCRIPTION (VAULT): 2003T/R ASSEMBLAGE NKA UMB01 BLOCK 5 FAIRWEST NORTH LOT 02 BLOCK 05 FAIRWEST NORTH  
 COMMUNITY PLANNING PERMITS:  
 Zoning: 15699  
 Zoning: 17848

AMCO KEY:

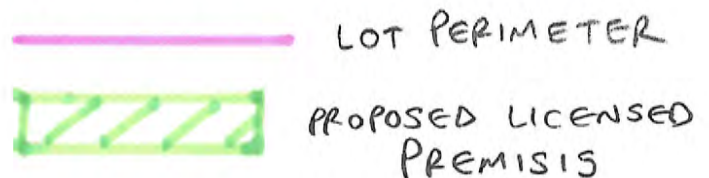

DIAGRAM 4

AMCO  
 JAN 10 2020

**Assessment History**

No Data Available...

The Fairbanks North Star Borough does not warrant the accuracy of maps or data provided, nor their suitability for any particular application. There may be errors in the data.





# Fairbanks North Star Borough

PAN# 0525227

All Data Report : G SUITE STRIP MALL  
"UNIVERSITY SQUARE MALL"

Printed on: 09/13/2019



# 1



ENTIRE BLDG. - 9380 SQ. FEET

DIAGRAM 5

AMCO KEY

 LICENSED LAWFUL RIGHT TO POSSESSION  
 PROPOSED LICENSED PREMISIS

AMCO  
JAN 1 0 2020

NORTH

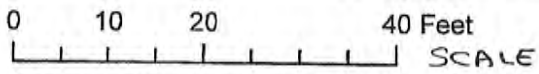



# MEMORANDUM

City of Fairbanks Clerk's Office

D. Danyielle Snider, City Clerk

---

TO: Mayor Jim Matherly and City Council Members  
FROM: D. Danyielle Snider, CMC, City Clerk   
SUBJECT: Application for New Retail Marijuana Store License  
DATE: April 7, 2020

---

Attached you will find a notification from the Alcohol and Marijuana Control Office (AMCO) of an application for a new Retail Marijuana Store License and additional information for the following applicant:

License #: **20827**  
License Type: **Retail Marijuana Store**  
D.B.A.: Good Titrations  
Licensee/Applicant: FSE, Inc.  
Physical Location: 506 Merhar Avenue, Fairbanks, Alaska

Pursuant to FGC Sec. 14-214 and 3 AAC 306.060, the Council must determine whether to protest the marijuana license application after holding a public hearing.

A notice of the date, time, and place of the public hearing has been mailed to all property owners within 1,000 feet of the proposed retail marijuana store, and notice of the public hearing will be advertised in the Fairbanks Daily News Miner on Friday, April 10, 2020.

The the Police Department has included a one-year call report for the location, but Chief Reeder is not recommending protest. The Building and Fire Departments are recommending protest until construction is complete and a Certificate of Occupancy is issued. There are no other departmental objections to the issuance of the license.

**CITY OF FAIRBANKS PUBLIC SAFETY**

**Good Titrations 506 Merhar Ave**

04/01/2019 - 03/30/2020

| <b>Report #</b> | <b>Call Time</b> | <b>Nature</b>    | <b>Location</b> | <b>Prime Unit</b> | <b>Disp.</b> | <b>Close Time</b>   |
|-----------------|------------------|------------------|-----------------|-------------------|--------------|---------------------|
|                 | 01/18/2020 15:07 | URGENT WELFARE   | 506 MERHAR AVE  | O50               | NRP          | 01/18/2020 15:37:46 |
|                 | 01/13/2020 14:35 | TRESPASS/UNWANTE | 506 MERHAR AVE  | O13               | NRP          | 01/13/2020 15:24:14 |
|                 | 01/03/2020 15:33 | SUSP             | 506 MERHAR AVE  | S6                | NRP          | 01/03/2020 15:47:38 |
|                 | 06/08/2019 17:56 | ALARM BURGLARY - | 506 MERHAR AVE  | S3                | FAB          | 06/08/2019 18:13:43 |
|                 | 05/22/2019 11:11 | ALARM BURGLARY - | 506 MERHAR AVE  | O3                | FAB          | 05/22/2019 11:40:46 |

Total Number of Events Listed: **5**



# City of Fairbanks

Office of the City Clerk

800 Cushman Street

Fairbanks, AK 99701

(907)459-6715  
Fax (907)459-6710

## ALCOHOL AND MARIJUANA CONTROL OFFICE MARIJUANA LICENSE RESPONSE FORM

- TO:  FINANCE DEPARTMENT  
 BUILDING DEPARTMENT  
 FIRE DEPARTMENT  
 POLICE DEPARTMENT

DATE: 03/03/2020

FROM: CITY CLERK'S OFFICE

RE: MARIJUANA LICENSE ACTION – NEW RETAIL LICENSE APPLICATION

DATE NOTICE RECEIVED AT CLERKS OFFICE: 03/03/2020 (60 DAY DUE DATE 05/01/2020)

DATE RESPONSE DUE: **04/07/2020** for City Council Meeting of 04/13/2020

License #: 20827  
 License Type: Retail Marijuana Store  
 D.B.A.: Good Titrations  
 Licensee/Applicant: FSE, Inc.  
 Physical Location: 506 Merhar Avenue, Fairbanks, Alaska

| Corp/LLC Agent:            | Mailing Address                        | Phone        | Date and State of Ltd/Partner/Corp | Good Standing? |
|----------------------------|--|--------------|------------------------------------|----------------|
| FSE, Inc.<br>Frank Berardi | 801 Pelican Way<br>Fairbanks, AK 99709 | 907-231-2943 | 01/14/2015 – AK                    | Yes            |

Please note: Members/Officers/Directors listed below are the principal members. There may be additional shareholders. All members who hold at least 10% shares are listed.

| Member/Officer/Affiliate: | Mailing Address                                    | Phone        | Title/Shares (%)  |
|---------------------------|--|--------------|---|
| Brandon Emmett            | 1299 Lowbush Lane<br>Fairbanks, AK 99709           | 907-328-8529 | Vice President/Director/Secretary/<br>Shareholder – 25% |
| Frank Berardi             | 801 Pelican Way<br>Fairbanks, AK 99709             | 907-231-2943 | President/Director/Shareholder – 25%                    |
| Shaun Tacke               | 1770 Donald Avenue, Suite B<br>Fairbanks, AK 99701 | 907-978-7647 | Treasurer/Director/Shareholder – 25%                    |

### ADDITIONAL COMMENTS:

NO PROTEST:  
COMMENTS

PROTEST REASONS: UNTIL CERTIFICATE OF OCCUPANCY IS ISSUED

DEPARTMENT SIGNEE: [Signature] / CLEMENS M. CLOOTEN  
 (Signature) (Printed Name)

NOTE: THIS COMPLETED FORM MUST BE RETURNED TO THE CITY CLERK'S OFFICE  
 BY THE DATE INDICATED ABOVE. YOU MAY E-MAIL OR FAX (459-6710) THE FORM.  
 IF YOU HAVE ANY QUESTIONS CALL OUR OFFICE AT 459-6774. THANK YOU.





# City of Fairbanks

Office of the City Clerk

800 Cushman Street

Fairbanks, AK 99701

(907)459-6715  
Fax (907)459-6710

## ALCOHOL AND MARIJUANA CONTROL OFFICE MARIJUANA LICENSE RESPONSE FORM

- TO:  FINANCE DEPARTMENT  
 BUILDING DEPARTMENT  
 FIRE DEPARTMENT  
 POLICE DEPARTMENT

DATE: 03/03/2020

FROM: CITY CLERK'S OFFICE

RE: MARIJUANA LICENSE ACTION – NEW RETAIL LICENSE APPLICATION

DATE NOTICE RECEIVED AT CLERKS OFFICE: 03/03/2020 (60 DAY DUE DATE 05/01/2020)

DATE RESPONSE DUE: **04/07/2020** for City Council Meeting of 04/13/2020

License #: 20827  
License Type: Retail Marijuana Store  
D.B.A.: Good Titrations  
Licensee/Applicant: FSE, Inc.  
Physical Location: 506 Merhar Avenue, Fairbanks, Alaska

| Corp/LLC Agent:            | Mailing Address                        | Phone        | Date and State of Ltd/Partner/Corp | Good Standing? |
|----------------------------|--|--------------|------------------------------------|----------------|
| FSE, Inc.<br>Frank Berardi | 801 Pelican Way<br>Fairbanks, AK 99709 | 907-231-2943 | 01/14/2015 – AK                    | Yes            |

Please note: Members/Officers/Directors listed below are the principal members. There may be additional shareholders. All members who hold at least 10% shares are listed.

| Member/Officer/Affiliate: | Mailing Address                                    | Phone        | Title/Shares (%)  |
|---------------------------|--|--------------|---|
| Brandon Emmett            | 1299 Lowbush Lane<br>Fairbanks, AK 99709           | 907-328-8529 | Vice President/Director/Secretary/<br>Shareholder – 25% |
| Frank Berardi             | 801 Pelican Way<br>Fairbanks, AK 99709             | 907-231-2943 | President/Director/Shareholder – 25%                    |
| Shaun Tacke               | 1770 Donald Avenue, Suite B<br>Fairbanks, AK 99701 | 907-978-7647 | Treasurer/Director/Shareholder – 25%                    |

### ADDITIONAL COMMENTS:

- NO PROTEST:  
COMMENTS
- PROTEST  
REASONS: Construction and Certificate of Occupancy incomplete

DEPARTMENT SIGNEE: James N. Styers / James N. Styers  
(Signature) (Printed Name)

NOTE: THIS COMPLETED FORM MUST BE RETURNED TO THE CITY CLERK'S OFFICE  
BY THE DATE INDICATED ABOVE. YOU MAY E-MAIL OR FAX (459-6710) THE FORM.  
IF YOU HAVE ANY QUESTIONS CALL OUR OFFICE AT 459-6774. THANK YOU.



# Alcohol & Marijuana Control Office

**License Number:** 20827

**License Status:** New

**License Type:** Retail Marijuana Store

**Doing Business As:** GOOD TITRATIONS

**Business License Number:** 1040494

**Designated Licensee:** Shaun Tacke

**Email Address:** shaun@goodtitrations.com

**Local Government:** Fairbanks (City of)

**Community Council:**

**Latitude, Longitude:** 64.858000, -147.694000

**Physical Address:** 506 Merhar Ave  
Fairbanks, AK 99701  
UNITED STATES

### Licensee #1

**Type:** Entity

**Alaska Entity Number:** 10026238

**Alaska Entity Name:** FSE, Inc.

**Phone Number:** 907-978-7647

**Email Address:** shaun@goodtitrations.com

**Mailing Address:** 1770 Donald Ave  
Suite B  
Fairbanks, AK 99701  
UNITED STATES

### Entity Official #1

**Type:** Individual

**Name:** Joshua Spence

**Phone Number:** 907-488-1823

**Email Address:** spencej@live.com

**Mailing Address:** 2296 Outside Blvd  
North Pole, AK 99705  
UNITED STATES

### Entity Official #2

**Type:** Individual

**Name:** Joanne Ellsworth

**Phone Number:** 907-451-9401

**Email Address:** dickells74@gmail.com

**Mailing Address:** 2581 Goldstream Rd  
Fairbanks, AK 99709  
UNITED STATES

### Entity Official #3

**Type:** Individual

**Name:** Martin Tacke

**Phone Number:** 907-460-2472

**Email Address:** marty.tacke@gmail.com

**Mailing Address:** 1770 Donald Ave  
Fairbanks, AK 99701  
UNITED STATES

### Entity Official #4

**Type:** Individual

**Name:** Naomi Johnson

**Phone Number:** 907-388-0446

**Email Address:** naomiraven.nj@gmail.com

**Mailing Address:** 100 10th Ave  
Apt 2B6  
Fairbanks, AK 99701  
UNITED STATES

### Entity Official #5

**Type:** Individual

**Name:** Frank Berardi

**Phone Number:** 907-231-2943

**Email Address:** frankberardi185@gmail.com

**Mailing Address:** 801 Pelican Way  
Fairbanks, AK 99709  
UNITED STATES

**Entity Official #6**

**Type:** Individual

**Name:** Judy Bath

**Phone Number:** 907-488-9451

**Email Address:** jkbath@hotmail.com

**Mailing Address:** 545 Freeman Rd  
North Pole, AK 99705  
UNITED STATES

**Entity Official #7**

**Type:** Individual

**Name:** Dawson Carroll

**Phone Number:** 907-687-6097

**Email Address:** dawsoncarroll74@yahoo.com

**Mailing Address:** 163 Carlyle Way  
Fairbanks, AK 99709  
UNITED STATES

**Entity Official #8**

**Type:** Individual

**Name:** Craig O'Donoghue

**Phone Number:** 907-378-3645

**Email Address:** fairbanksdentist@gmail.com

**Mailing Address:** 4740 Villanova Dr  
#A  
Fairbanks, AK 99709  
UNITED STATES

**Entity Official #9**

**Type:** Individual

**Name:** Shaun Tacke

**Phone Number:** 907-978-7647

**Email Address:** shaun@goodtitrations.com

**Mailing Address:** 1770 Donald Ave  
Suite B  
Fairbanks, AK 99701  
UNITED STATES

**Entity Official #10**

**Type:** Individual

**Name:** Seth Hawkins

**Phone Number:** 907-347-4372

**Email Address:** sethhawkins@hotmail.com

**Mailing Address:** PO Box 70018  
Fairbanks, AK 99707  
UNITED STATES

**Entity Official #11**

**Type:** Individual

**Name:** Lynn Crane

**Phone Number:** 907-581-3248

**Email Address:** unakwoman@yahoo.com

**Mailing Address:** PO Box 626  
Unalaska, AK 99685  
UNITED STATES

**Entity Official #12**

**Type:** Individual

**Name:** Jeffrey Weltzin

**Phone Number:** 907-590-1305

**Email Address:** jeffreyweltzin@gmail.com

**Mailing Address:** 3844 Ullrbahn Rd  
Fairbanks, AK 99709  
UNITED STATES

**Entity Official #13**

**Type:** Individual

**Name:** Brandon Emmett

**Phone Number:** 907-328-8529

**Email Address:** emmett@goodtitrations.com

**Mailing Address:** 1299 Lowbush Lane  
Fairbanks, AK 99709  
UNITED STATES

**Entity Official #14**

**Type:** Individual

**Name:** Curtis Franklin

[REDACTED]

[REDACTED]

**Phone Number:** 907-322-7945

**Email Address:** curtfran68@gmail.com

**Mailing Address:** 3760 Mitchell Ave  
Fairbanks, AK 99709  
UNITED STATES

**Entity Official #15**

**Type:** Individual

**Name:** Billie Jo Gehring

[REDACTED]

[REDACTED]

**Phone Number:** 907-359-2246

**Email Address:** billiejogehring@gmail.com

**Mailing Address:** PO Box 226  
Unalaska, AK 99685  
UNITED STATES

**Entity Official #16**

**Type:** Entity

**Alaska Entity Number:** 10039028

**Alaska Entity Name:** U.N.ME, LLC

**Phone Number:** 662-694-9025

**Email Address:** mbroach1@gmail.com

**Mailing Address:** 607 Old Steese Hwy  
Suite B #209  
Fairbanks, AK 99701  
UNITED STATES

**Entity Official #17**

**Type:** Individual

**Name:** Melissa Cervantes

[REDACTED]

[REDACTED]

**Phone Number:** 662-694-9025

**Email Address:** mbroach1@gmail.com

**Mailing Address:** 607 Old Steese Hwy  
Suite B209  
Fairbanks, AK 99701  
UNITED STATES

**Entity Official #18**

**Type:** Individual

**Name:** Michael Cervantes

[REDACTED]

[REDACTED]

**Phone Number:** 907-460-2704

**Email Address:** michael@goodtitrations.com

**Mailing Address:** 607 Old Steese Hwy  
Ste B209  
Fairbanks, AK 99701  
UNITED STATES

*Note: No affiliates entered for this license.*



## Alaska Marijuana Control Board Operating Plan Supplemental Form MJ-03: Retail Marijuana Store

### What is this form?

This operating plan supplemental form is required for all applicants seeking a retail marijuana store license and must accompany **Form MJ-01: Marijuana Establishment Operating Plan**, per 3 AAC 306.020(b)(11). Applicants should review **Chapter 306: Article 3** of the **Alaska Administrative Code**. This form will be used to document how an applicant intends to meet the requirements of the statutes and regulations.

If your business has a formal operating plan, you may include a copy of that operating plan with your application, but all fields of this form must still be completed per 3 AAC 306.020 and 3 AAC 306.315(2).

### What additional information is required for retail stores?

Applicants must identify how the proposed establishment will comply with applicable regulations regarding the following:

- Prohibitions
- Signage and advertising
- Displays and sales
- Exit packaging and labeling
- Security
- Waste disposal

**This form must be completed and submitted to AMCO's main office before any new or transfer application for a retail marijuana store license will be considered complete.**

### Section 1 – Establishment Information

Enter information for the business seeking to be licensed, as identified on the license application.

|                    |                        |               |        |      |       |
|--------------------|------------------------|---------------|--------|------|-------|
| Licensee:          | FSE, Inc.              | MJ License #: | 20827  |      |       |
| License Type:      | Marijuana Retail Store |               |        |      |       |
| Doing Business As: | Good Titrations        |               |        |      |       |
| Premises Address:  | 506 Merhar Avenue      |               |        |      |       |
| City:              | Fairbanks              | State:        | Alaska | ZIP: | 99701 |



Section 2 – Overview of Operations

2.1. Provide an overview of your proposed facility's operations. Include information regarding the intake and flow of marijuana and marijuana product at your premises, and a description of what a standard customer visit to your establishment would entail:

Each shipment of marijuana and marijuana product that arrive at Good Titrations will be inspected by a member of the management team before it is accepted and added to the store's inventory. The shipment will be reconciled with the transport manifest, shipment labels and packaging labels to ensure consistency. All product will be weighed and reconciled with the weight listed on the manifest and labels. Any shipments with discrepancies will be rejected. Shipments that pass initial inspection will be accepted into the facility, entered into METRC and the point of sale software and added to the store's inventory storage or display cases. At the end of each business day, the management team will reconcile the sale's transactions from the point of sale software with the inventory on hand and with METRC to ensure consistency. Any discrepancies will be immediately addressed. When customers enter the retail store, they will immediately be asked for ID. Once ID has been verified, customers can then browse the retail store. After customers completes their transaction, they will exit the licensed premises. Loitering will not be tolerated.

Section 3 – Prohibitions

Review the requirements under 3 AAC 306.310.

3.1. Describe how you will ensure that the retail marijuana store will not sell, give, distribute, or deliver marijuana or marijuana product to a person who is under the influence of an alcoholic beverage, inhalant, or controlled substance:

All customers will enter the designated entrance door to the facility where they will immediately be checked for identification. All employees will be trained to recognize the signs of impairment. If any employee suspects a customer of being impaired, the person will be asked to leave the premises. If an individual in the retail area appears to be impaired, the retail agents have the authority to refuse service to anyone and have the customer removed from the premises.

3.2. I certify that the retail marijuana store will not:

Initials

- a. sell, give, distribute, deliver, or offer to sell, give, distribute, or deliver marijuana or marijuana product in a quantity exceeding the limit set out in 3 AAC 306.355;
- b. sell, give, distribute, deliver, or offer to sell, give, distribute, or deliver marijuana or marijuana product over the internet;
- c. offer or deliver to a consumer, as a marketing promotion or for any other reason, free marijuana or marijuana product, including a sample;
- d. offer or deliver to a consumer, as a marketing promotion or for any other reason, alcoholic beverages, free or for compensation; or
- e. allow a person to consume marijuana or a marijuana product on the licensed premises.

ST  
ST  
ST  
ST  
ST

Answer "Yes" or "No" to the following question:

Yes No

3.3. Do you plan to request future approval of the Marijuana Control Board to permit consumption of marijuana or marijuana product in a designated area on the proposed premises?





# Form MJ-03: Retail Marijuana Store Operating Plan Supplemental

## Section 4 – Signage and Advertising

Review the requirements under 3 AAC 306.360 and 3 AAC 306.365. All licensed retail marijuana stores must meet minimum standards for signage and advertising.

You must be able to certify each statement below. Read the following and then sign your initials in the corresponding box: Initials

4.1. I understand and agree to follow the limitations regarding the number, placement, and size of signs on my proposed establishment, set forth in 3 AAC 306.360(a).

ST

4.2. The retail marijuana store will not use giveaway coupons as promotional materials, or conduct promotional activities such as games or competitions to encourage the sale of marijuana or marijuana products.

ST

4.3. All advertising for marijuana or marijuana product will contain the warnings required under 3 AAC 306.360(e).

ST

4.4. I understand and agree to post, in a conspicuous location visible to customers, the notification signs required under 3 AAC 306.365.

ST

4.5. I certify that no advertisement for marijuana or marijuana product will contain any statement or illustration that:

ST

a. is false or misleading;

b. promotes excessive consumption;

c. represents that the use of marijuana has curative or therapeutic effects;

d. depicts a person under the age of 21 consuming marijuana; or

e. includes an object or character, including a toy, a cartoon character, or any other depiction designed to appeal to a child or other person under the age of 21, that promotes consumption of marijuana.

ST

ST

ST

ST

4.6. I certify that no advertisement for marijuana or marijuana product will be placed:

a. within 1,000 feet of the perimeter of any child-centered facility, including a school, childcare facility, or other facility providing services to children, a playground or recreation center, a public park, a library, or a game arcade that is open to persons under the age of 21;

b. on or in a public transit vehicle or public transit shelter;

c. on or in a publicly owned or operated property;

d. within 1,000 feet of a substance abuse or treatment facility; or

e. on a campus for postsecondary education.

ST

ST

ST

ST

ST

## Section 5 – Displays and Sales

5.1. Describe how marijuana and marijuana products at the retail marijuana store will be displayed and sold:

All marijuana and marijuana products will be displayed in locked and secured display cases and cabinets behind the POS counters which require employee assistance to access. Only smell sample jars will be reachable to the customers. "Smell jars" will be covered with a plastic, metal or other type of mesh tamper-evident cover. Product displays will always be in full view of a working video surveillance camera. Marijuana and marijuana products will be placed in the secured displays at opening and will only be on display during business hours. Only marijuana that is packaged and labeled in accordance with all state and municipal laws and regulations, and in accordance with Good Titrations policies, will be placed in product displays and accessed for sale to the public. All employees will be trained and regularly monitored to ensure compliance with the display and closing policies, and that all product is secured and accounted for. All edibles, concentrates, and flowers for sale, will be stored behind the POS counter. All products on the shopping floor will be for display only. Cashiers will take the customer order and fulfill them from behind the counter. Any non-marijuana inventory will be stored in the designated non-marijuana display area or out on the shopping floor in a separate display case/rack.



# Form MJ-03: Retail Marijuana Store Operating Plan Supplemental

## Section 6 – Exit Packaging and Labeling

Review the requirements under 3 AAC 306.345.

6.1. Describe how the retail marijuana store will ensure that marijuana and marijuana products sold on its licensed premises will meet the packaging and labeling requirements set forth in 3 AAC 306.345(a):

All marijuana and marijuana products sold at our retail location will be delivered by a state of Alaska licensed cultivation or manufacturing facility. All shipments to the retail facility will be inspected for quality and consistency with the transport manifest and shipment labels, and for regulatory compliance. Labels will be checked for: (1) name and license number of the manufacturing or cultivation facility; (2) production lot and/or batch number; (3) strain information; (4) net weight of the product (5) packaging date and expiration date; and (6) testing lab name and license number. The transport manifest will be checked for: (1) name and license number of the providing entity; (2) delivery date; (3) start time and estimated arrival time; (4) strain and batch information; (5) delivery driver name and handler's card verification; (6) the weight of the products transferred; and (7) testing information. Continued pg 6

6.2. Provide a sample label that the retail marijuana store will use to meet the labeling requirements set forth in 3 AAC 306.345(b):

**Produced By:** Good Titrations  
**License Number:** 20827  
**Product Name:** **Strain:**  
**Batch/Lot Number:** **Gross Weight:** **Net MJ Weight:** OZ ( g)  
**Best By Date:** **Packaging Date:**  
**Tested By:** **License Number:**  
**Total THC:** **THCA:** **CBD:** **CBDA:** **CBN:**  
**Microbial Test:** **Pesticides:** **Herbicides:**  
**Fungicides:**  
**Residual Solvent Test:** **Contaminants Test Result:**  
Retailer: License Number:

**Alaska Safety Warning:** Marijuana has intoxicating effects and may be habit forming and addictive. Marijuana impairs concentration, coordination and judgment. Do not operate a vehicle or machinery under its influence. There are health risks associated with consumption of marijuana. For use only by adults twenty-one and older. Keep out of the reach of children. Marijuana should not be used by women who are pregnant or breast feeding.

**\*Keep Refrigerated\*** Label will include nutritional information & full list of ingredients

\* or similar format and content





# Form MJ-03: Retail Marijuana Store Operating Plan Supplemental

## Section 7 – Security

Review the requirements under 3 AAC 306.350 and 3 AAC 306.720.

7.1. Describe the retail marijuana store's procedures for ensuring a form of valid photographic identification has been produced before selling marijuana or marijuana product to a person, as required by 3 AAC 306.350(a):

A designated employee will check the ID of every person attempting to enter the retail store. Anyone under the age of 21 or who does not produce a valid form of photo ID such as; a current passport, current driver's license, state ID, territory of the US ID, the District of Columbia, a province or territory of Canada or ID issued by a federal or state agency authorized to issue ID cards will not be granted access to the facility. Any employee checking ID's will have a valid marijuana handler permit and be trained to recognize altered/forged photo ID's.

You must be able to certify the statement below. Read the following and then sign your initials in the box to the right: Initials

7.2. The video surveillance and camera recording system for the licensed premises covers each point-of-sale area.

ST

## Section 8 – Waste Disposal

Review the requirements under 3 AAC 306.740.

8.1. Describe how you will store, manage, and dispose of any marijuana waste, including expired marijuana or marijuana products, in compliance with any applicable laws. Include details about the material(s) you will mix with ground marijuana waste and the processes that you will use to make the marijuana waste unusable for any purpose for which it was grown or produced:

Good Titrations has a disposal plan for marijuana waste and all products that do not meet state testing requirements or the company's internal quality standards for any reason. Good Titrations will be disposing of: (1) marijuana that is identified as contaminated, infected or is otherwise rejected for quality or fails to meet quality testing; (2) all packaging, labeling, containers, or other related materials which arrive at the facility with marijuana products that have been disqualified for quality; (3) expired marijuana products and (4) any other materials or containers in contact with marijuana products that risk contamination. Marijuana waste will be stored away from all other products in a locked container inside the facility and will be rendered unusable prior to leaving the facility for disposal. Marijuana waste will be rendered unusable by grinding or mixing the materials with other compostable and non-compostable material such as, food waste, cardboard, paper, and yard waste; until the resulting mixture is no more than fifty percent (50%) marijuana waste. Management will maintain a log on the status of all marijuana waste, tracking the type, date of disposal, date it was rendered unusable, and date that it was picked up by the disposal company. The final mixture will be securely stored in locked containers located inside the premises with locks in compliance with the highest UL standards.

You must be able to certify the statement below. Read the following and then sign your initials in the box to the right: Initials

8.2. The retail marijuana store shall give the board at least three days written notice required under 3 AAC 306.740(c) before making marijuana waste unusable and disposing of it.

ST

I declare under penalty of unsworn falsification that this form, including all accompanying schedules and statements, is true, correct, and complete.

*[Handwritten Signature]*  
Signature of licensee

Shaun Tacke  
Printed name of licensee

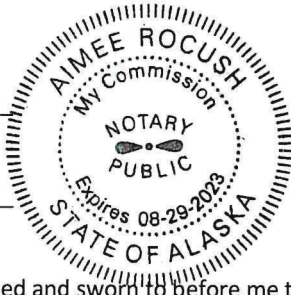

*Aimee Rocush*  
Notary Public in and for the State of Alaska

My commission expires: 8/29/2023

Subscribed and sworn to before me this 20 day of December, 2019.





# Form MJ-03: Retail Marijuana Store Operating Plan Supplemental

(Additional Space as Needed):

6.1 Once a delivery is approved by either the general manager or a member of ownership, the inventory will be accepted into the retail facility and entered into METRC with all mandatory information designated by AMCO. The shipment information will be both recorded in METRC and stored on-site as official business records. Company agents will sign all paperwork and documents expressing that all information is deemed correct and the transfer took place. Shall any of the above be missing or inaccurate, the general manager will refuse the transfer.



## Alaska Marijuana Control Board Form MJ-02: Premises Diagram

### What is this form?

A detailed diagram of the proposed licensed premises is required for all marijuana establishment license applications, per 3 AAC 306.020(b)(8). **All areas designated as the licensed premises of a single license must be contiguous. All diagrams must have the licensed premises area labeled, and outlined or shaded as appropriate.**

### What must be submitted with this form?

Applicants must attach multiple diagrams to this form, including (as applicable):

- **Diagram 1:**  
a diagram showing only the licensed premises areas that will be ready to be operational at the time of your preliminary inspection and license issuance;
- **Diagram 2:**  
if different than Diagram 1, a diagram outlining all areas for which the licensee has legal right of possession (a valid lease or deed), and clearly showing those areas' relationship to the current proposed licensed premises (*details of any planned expansion areas do not need to be included; a complete copy of Form MJ-14: Licensed Premises Diagram Change must be submitted and approved before any planned expansion area may be added to the licensed premises*);
- **Diagram 3:**  
a site plan or as-built of the entire lot, showing all structures on the property and clearly indicating which area(s) will be part of the licensed premises;
- **Diagram 4:**  
an aerial photo of the entire lot and surrounding lots, showing a view of the entire property and surrounding properties, and clearly indicating which area(s) will be part of the licensed premises (*this can be obtained from sources like Google Earth*); and
- **Diagram 5:**  
a diagram of the entire building in which the licensed premises is located, clearly distinguishing the licensed premises from unlicensed areas and/or premises of other licenses within the building. If your proposed licensed premises is located within a building or building complex that contains multiple business and/or tenants, please provide the addresses and/or suite numbers of the other businesses and/or tenants (*a separate diagram is not required for an establishment that is designating the entire building as a single licensed premises*).

This form, and all necessary diagrams that meet the requirements on Page 2 of this form, must be completed and submitted to AMCO's main office before any new or transfer license application will be considered complete.

### Section 1 – Establishment Information

Enter information for the business seeking to be licensed, as identified on the license application.

|                    |                        |               |        |      |       |  |
|--------------------|------------------------|---------------|--------|------|-------|--|
| Licensee:          | FSE, Inc.              | MJ License #: | 20827  |      |       |  |
| License Type:      | Marijuana Retail Store |               |        |      |       |  |
| Doing Business As: | Good Titrations        |               |        |      |       |  |
| Premises Address:  | 506 Merhar Avenue      |               |        |      |       |  |
| City:              | Fairbanks              | State:        | Alaska | ZIP: | 99701 |  |



# Form MJ-02: Premises Diagram

## Section 2 – Required Information

For your security, do not include locations of security cameras, motion detectors, panic buttons, and other security devices. Items marked with a double asterisks (\*\*) are only required for those retail marijuana establishments that are also applying for an onsite consumption endorsement.

The following details must be included in all diagrams:

- License number and DBA
- Legend or key
- Color coding
- Licensed Premises Area Labeled and Shaded, or Outlined as appropriate
- Dimensions
- Labels
- True north arrow

The following additional details must be included in Diagram 1:

- Surveillance room
- Restricted access areas
- Storage areas
- Entrances, exits, and windows
- Walls, partitions, and counters
- Any other areas that must be labeled for specific license or endorsement types
- \*\* Serving area(s)
- \*\*Employee monitoring area(s)
- \*\*Ventilation exhaust points, if applicable

The following additional details must be included in Diagram 2:

- Areas of ingress and egress
- Entrances and exits
- Walls and partitions

The following additional details must be included in Diagrams 3 and 4:

- Areas of ingress and egress
- Cross streets and points of reference

The following additional details must be included in Diagram 5:

- Areas of ingress and egress
- Entrances and exits
- Walls and partitions
- Cross streets and points of reference

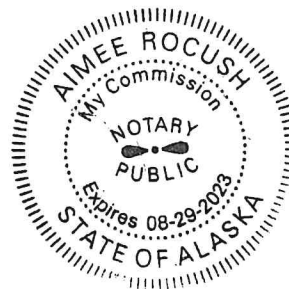

I declare under penalty of unsworn falsification that I have attached all necessary diagrams that meet the above requirements, and that this form, including all accompanying schedules, statements, and depictions is true, correct, and complete.

Signature of licensee

Shawn Tucke

Printed name of licensee

Aimee Rocush

Notary Public in and for the State of Alaska

My commission expires: 8/29/2023

Subscribed and sworn to before me this 20 day of December, 2019.



Diagrams 1, 2, & 5 (N) FREEZER WALLS, INSTALL PER MFR

SHEET NOTES (PLANS)

- DIMENSIONS ARE TO FACE OF STUD, FACE OF CONCRETE, GRID LINES, AND CENTER LINE OF WINDOW ASSEMBLIES UNLESS OTHERWISE NOTED.
- CONSTRUCTION ASSEMBLY DESCRIPTIONS, SEE A1.0.
- PRODUCT SPECIFICATIONS, SEE A1.0.
- ACCESSIBILITY AND ADA DETAILS, SEE A6.0.
- OPERABLE PARTS OF LIGHTING, ENVIRONMENTAL SECURITY CONTROLS AND ELECTRICAL RECEPTACLES SHALL BE MOUNTED BETWEEN 15" AND 48" ABOVE FINISHED FLOOR.
- ALL FAUCETS TO HAVE LEVER HANDLES.
- REMOVE EXISTING TILE, GRIND AND POLISH EXISTING CONCRETE, TYP THROUGHOUT. IF ANY TILE REMAINS OR IS REPLACED DURING CONSTRUCTION, VERIFY ADA COMPLIANCE AT FLOOR TRANSITION PER 2/A6.0.

PHASING LEGEND

- EXISTING TO REMAIN
- REMOVED DURING DEMO PHASE (DEMO PLANS ONLY)
- NEW CONSTRUCTION (NEW PLANS ONLY)



PERMIT SET REVISIONS (REFERENCE ONLY)

- Proposed Licensed premises
- Restricted Access Area
- ID check
- Shared Video Surveillance + Recording Storage
- Cultivation License #20829
- Manufacturing License #20832

Good Titrations License #20827 506 Merhar Avenue Fairbanks, AK Retail

| # | Date     | Description |
|---|----------|-------------|
| 1 | 10.14.19 |             |
|   | SM       | Drawn By    |

Floor Plan

A2.0

Copyright 2019 © If this drawing is less than 22" x 34", it has been reduced. Scale accordingly. Half size at 11" x 17"

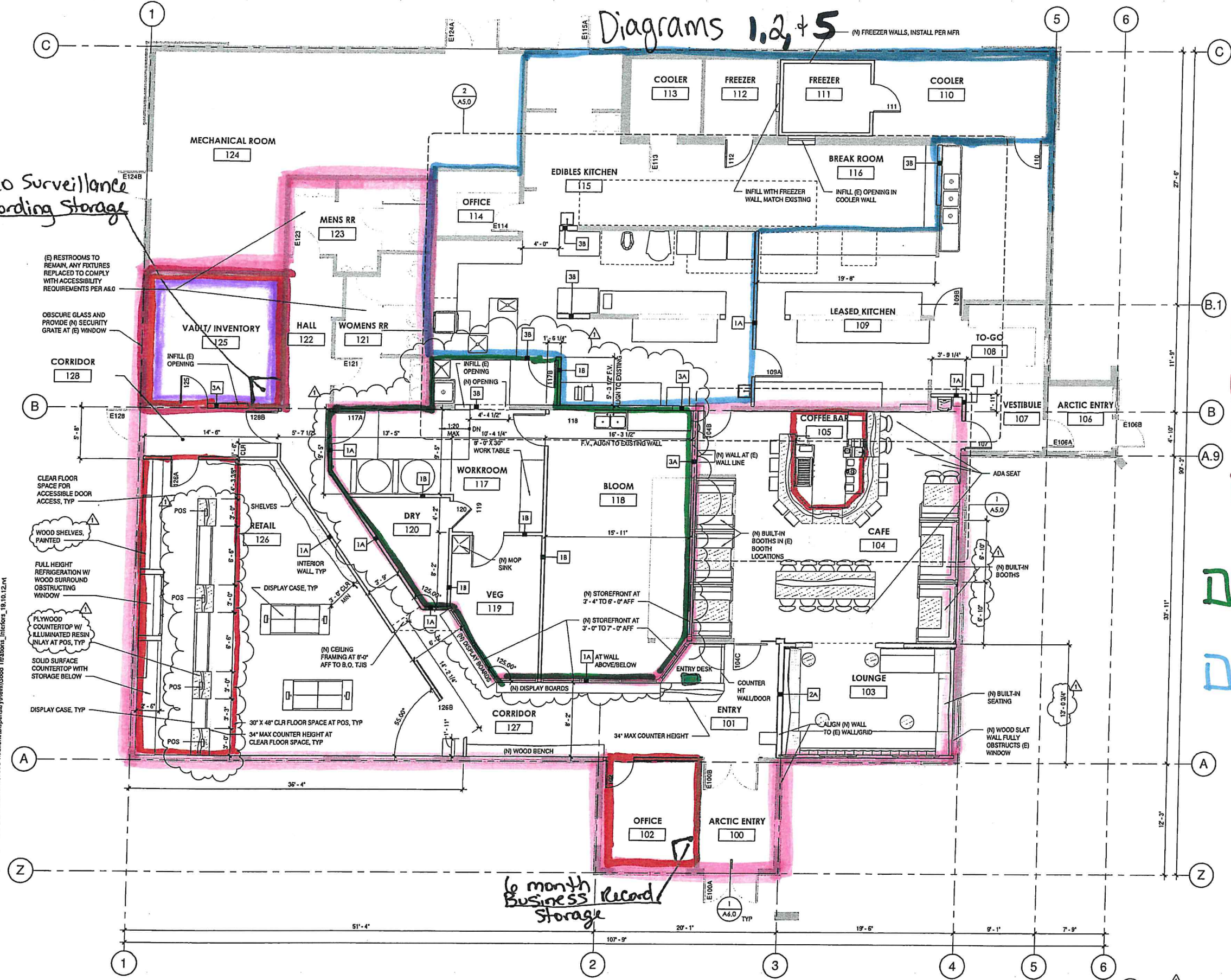

Video Surveillance + Recording Storage

6 month Business Record Storage

1 GROUND FLOOR PLAN A2.0 SCALE: 3/16" = 1'-0"

Plot Date: 10/14/2019 9:38:33 PM Revit File: \\wy\dshel\j0004 - PROJECT Files\Good Titrations\Revit\Good Titrations\_Interiors\_19.10.12.rvt



# GOOD TITRATIONS

Diagram 3

## GENERAL NOTES

- CONTRACTOR SHALL VERIFY ALL EXISTING CONDITIONS AND DIMENSIONS PRIOR TO CONSTRUCTION AND SHALL NOTIFY DESIGNER OF ANY DEVIATIONS FROM DRAWINGS PRIOR TO CONTINUATION OF WORK.
- CONTRACTOR SHALL NOTIFY DESIGNER OF ANY NEED FOR DESIGN CHANGES DUE TO FIELD CONDITIONS OR OBSERVATIONS PRIOR TO CONTINUING WORK.
- WRITTEN DIMENSIONS HAVE PRECEDENCE OVER SCALED DIMENSIONS. DO NOT SCALE THE DRAWINGS.
- DIMENSIONS ARE TO FACE OF STUD, FACE OF CONCRETE, GRID LINES, AND CENTER LINE OF WINDOW ASSEMBLIES UNLESS OTHERWISE NOTED.
- SAFETY GLAZING IS REQUIRED WHERE GLASS IS WITHIN 16" OF THE FLOOR AND 24" OF DOORS. SEE 2017 ORSC SEC. R308 FOR ADDITIONAL SAFETY REQUIREMENTS.
- ALL MATERIALS AND WORK SHALL CONFORM TO ALL GOVERNING CODES AND REGULATIONS.
- ALL WORK TO BE DONE IN ACCORDANCE WITH THE LATEST CODES WITH LOCAL AMENDMENTS AND ORDINANCES AND GOOD STANDARD PRACTICE. CONTRACTOR TO COORDINATE ALL DIMENSIONS, SIZING AND OPENINGS WITH ALL TRADES. CONTRACTOR TO VERIFY ALL CONNECTOR SIZES TO INSURE PROPER FIT.
- ALL MATERIALS AND PRODUCTS SHALL BE INSTALLED IN ACCORDANCE WITH THE MANUFACTURERS WRITTEN INSTRUCTIONS.
- FRAMING CONTRACTOR TO VERIFY ALL ROUGH OPENING SIZES AND DETAILS FOR DOORS, WINDOWS, EXHAUST, FANS, AND VENTS.
- CONTRACTOR SHALL PROVIDE ALL NECESSARY TEMPORARY BRACING, SHORING, GUYING OR OTHER MEANS TO AVOID EXCESSIVE STRESSES AND TO HOLD STRUCTURAL ELEMENTS IN PLACE DURING CONSTRUCTION.
- ARCHITECT NOT RESPONSIBLE FOR WATER PENETRATION OF EXISTING ROOFING, FLASHING, OR PARAPETS.
- WHEN WORK NOT SPECIFICALLY CALLED OUT IS REQUIRED TO COMPLETE THE PROJECT, IT SHALL BE OF THE BEST MATERIAL AND WORKMANSHIP.
- CONTRACTOR SHALL TAKE ALL THE NECESSARY PRECAUTIONARY MEASURES TO PROTECT THE PUBLIC AND ADJACENT PROPERTIES FROM DAMAGE THROUGHOUT CONSTRUCTION. CONTRACTOR ASSUMES ALL LIABILITY FOR DAMAGES INCURRED DURING CONSTRUCTION.
- CONTRACTOR SHALL ESTABLISH AND VERIFY ALL OPENINGS AND INSERTS FOR MECHANICAL, ELECTRICAL, AND PLUMBING WITH APPROPRIATE TRADES.
- THE STARTING OF WORK BY THE GENERAL CONTRACTOR OR ANY SUBCONTRACTOR SHALL BE CONSIDERED PRIMA FACIE EVIDENCE THAT THEY HAVE INSPECTED AND ACCEPTED ALL CONDITIONS INVOLVED IN THE WORK AND FIND THEM SATISFACTORY.
- CONTRACTOR SHALL THE NEW UTILITIES INTO PRIVATE & PUBLIC LINES AS REQUIRED BY PUBLIC, PRIVATE UTILITIES OR COUNTY.
- CONTRACTOR SHALL COORDINATE WORK OF MECH. AND ELEC. SUBCONTRACTORS AND NOTIFY DESIGNER OF ANY CONFLICTS OR VARIATIONS FROM I.R.C. REQUIREMENTS. ALL WORK TO CONFORM TO ALL RELEVANT CODES AND REGULATIONS.
- CONTRACTOR SHALL BE RESPONSIBLE FOR OBTAINING ALL DEFERRED AND TRADE PERMITS.
- CONTRACTOR SHALL VERIFY AND CONFIRM ALL SIZES & DIMENSIONS PRIOR TO ORDERING.
- WHEN POSSIBLE, USE PRODUCTS MADE IN THE UNITED STATES. EXAMPLE OF A COMPREHENSIVE LIST OF PRODUCTS MADE IN THE USA CAN BE FOUND AT: <http://www.americansworking.com/buildingmaterial.html>

## ZONING INFORMATION

|  | CODE       | PROPOSED      |
|--|------------|---------------|
| MAX HEIGHT (INDOOR SMALL MARIJUANA CULTIVATION FACILITY) | 35'-0" MAX | < 35'-0"      |
| REQUIRED YARDS   | NOT REQ'D  | NO CHANGES    |
| MAX HEIGHT   | UNLIMITED  | NO CHANGES    |
| MAX LOT COVERAGE   | 100%       | NO CHANGES    |
| SMALL INDOOR CULTIVATION                                 | PERMITTED  | ACCESSORY USE |

## PARKING

RESTAURANT: 1 SPACE PER 3 SEATS: 47 SEATS / 3 = 16 SPACES  
STORE: 1 SPACE PER 200 SF SALES AREA: 837 SF / 200 = 4 SPACES  
ALL OTHER COMMERCIAL/INDUSTRIAL: 3 SPACES PER 4 EMPLOYEES:  
(22 EMPLOYEES / 4) X 3 = 17 SPACES  
ADA PARKING: 1 ADA STALL PER 50 SPACES

37 SPACES REQUIRED

## STORMWATER MANAGEMENT

NO CHANGES TO IMPERVIOUS AREA.

## BUILDING INFORMATION

|       | EXISTING | PROPOSED              |
|-------|----------|-----------------------|
| TOTAL | 7,800 SF | 7,800 SF (NO CHANGES) |

AREA OF MARIJUANA CULTIVATION FACILITY: 1,042 SF, ALL INDOOR

## SITE INFORMATION

|                   |   |
|-------------------|---|
| ADDRESS           | 506 MERHAR AVE, FAIRBANKS, AK 99701       |
| COUNTY            | FAIRBANKS NORTH STAR                      |
| LEGAL DESCRIPTION | LOT 3, TR A, BENTLEY BROTHERS SUBDIVISION |
| LOT SIZE          | .98 ACRES (41,782 sf)                     |
| BASE ZONE         | GU-1 (GENERAL USE)                        |

## JOB DESCRIPTION

TENANT IMPROVEMENT OF EXISTING A-2 RESTAURANT TO NON-SEPARATED MIXED OCCUPANCY A-2 CAFE AND KITCHEN, M MARIJUANA RETAIL AND F-1 SMALL INDOOR MARIJUANA CULTIVATION. NO CHANGES TO EXTERIOR ENVELOPE.

TO COMPLY WITH 2015 INTERNATIONAL BUILDING CODE AND CITY OF FAIRBANKS LOCAL AMENDMENTS TO THE 2015 INTERNATIONAL BUILDING CODE.

VALUATION: \$130,000

## VICINITY MAP

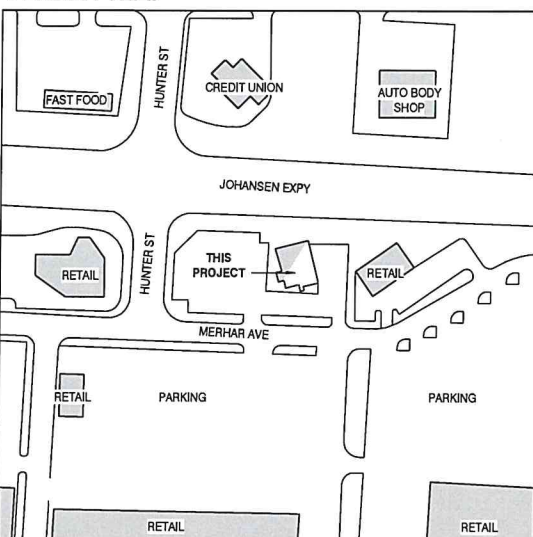

## TRADE PERMITS

MECHANICAL, ELECTRICAL, PLUMBING, FIRE SPRINKLER AND SIGN PERMITS TO BE OBTAINED SEPARATELY.

## PROJECT TEAM

### OWNER

HAPPY PEPPER, LLC  
1770 DONALD AVE  
FAIRBANKS AK 99701

907-328-8529  
info@goodtitrations.com

### ARCHITECT

HARKA ARCHITECTURE, LLC  
107 SE WASHINGTON ST, SUITE 740  
PORTLAND, OR 97214

CONTACT: PATRICK DONALDSON  
503-975-9471  
patrick@harka.com

### STRUCTURAL

NELSON ENGINEERING  
155 BIDARCA STREET  
KENAI, ALASKA 99611

CONTACT: ZACK RININGER  
907-283-3583  
ZRININGER@ALASKA.NET

## DRAWING SHEET INDEX

### ARCHITECTURAL

- A0.0 Project Info, Zoning / Code, & Site Plan
- A0.1 Life Safety Info & Plans
- A1.0 Assemblies, Schedules & Demo Plan
- A2.0 Floor Plan
- A2.1 Reflecting Ceiling Plan
- A3.0 Elevations
- A5.0 Enlarged Plans
- A5.1 Sections & Details
- A6.0 Accessibility Details

### INTERIOR DESIGN

- ID1.0 Finish / Material Schedules & Reference Plan
- ID2.0 Fixture / Furniture Plan
- ID3.0 Lighting Plan
- ID4.0 Interior Elevations
- ID4.1 Interior Elevations
- ID5.0 Interior Details
- ID5.1 Interior Details
- ID5.2 Interior Details

### STRUCTURAL

- S1.1 Notes and Specifications
- S1.2 Special Inspection
- S2.1 First Floor Framing Plan
- S3.1 Details

## LOW-CARBON NOTES

- ANNUAL SPACES AROUND PIPES, ELECTRIC CABLES, CONDUITS OR OTHER OPENINGS IN PLATES AT EXTERIOR WALLS SHALL BE PROTECTED AGAINST THE PASSAGE OF RODENTS BY CLOSING SUCH OPENINGS WITH CEMENT MORTAR, CONCRETE MASONRY OR SIMILAR ACCEPTABLE METHOD.
- A MINIMUM OF 50 PERCENT OF THE CONSTRUCTION WASTE GENERATED AT THE SITE SHALL BE DIVERTED TO RECYCLE OR SALVAGE.
- GAS FIREPLACES SHALL BE A DIRECT-VENT SEALED-COMBUSTION TYPE. WOOD/PELLET STOVES SHALL COMPLY WITH US EPA PHASE II EMISSION LIMITS.
- DUCT AND VENT OPENINGS SHALL BE COVERED DURING CONSTRUCTION.
- ADHESIVES, SEALANTS AND CAULKS SHALL BE COMPLIANT LOW OR NO VOC.
- PAINTS, STAINS, AND OTHER COATINGS SHALL BE COMPLIANT LOW OR NO VOC.
- MOISTURE CONTENT OF BUILDING MATERIALS USED IN ENCLOSED WALL AND FLOOR FRAMING IS CHECKED BEFORE ENCLOSURE AND CANNOT EXCEED 19%.
- HVAC SYSTEM INSTALLERS ARE TRAINED AND CERTIFIED IN THE PROPER INSTALLATION OF HVAC SYSTEMS.
- USE FSC, LOCAL, ENVIRONMENTALLY CERTIFIED, SUSTAINABLY-SOURCED PRODUCTS - FOR MORE INFORMATION AND RESOURCES VISIT SUSTAINABLE NW: <http://www.sustainablenorthwest.org/>
- MINIMIZE USE OF CONCRETE WHERE ALTERNATIVE IS POSSIBLE.

## SYMBOLS

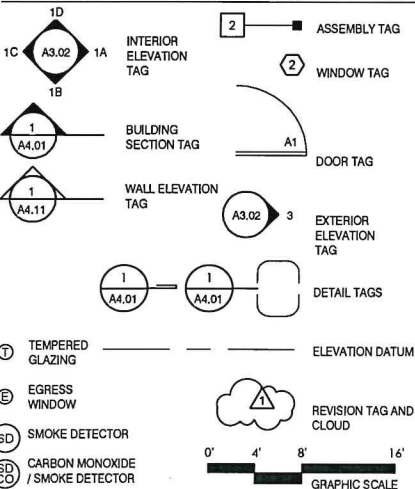

## ABBREVIATIONS

|         |                         |       |                               |         |                             |          |  |
|---------|-------------------------|-------|-------------------------------|---------|-----------------------------|----------|--|
| #       | NUMBER                  | EA    | EACH                          | IBC     | INTERNATIONAL BUILDING CODE | PERF     | PERFORATED, PERFORATE                          |
| A/C     | AIR CONDITIONING        | EJ    | EXPANSION JOINT               | IN      | INCH                        | PLAM     | PLASTIC LAMINATE                               |
| ADDL    | ADDITIONAL              | EL    | ELEVATION                     | INFO    | INFORMATION                 | PL       | PLATE, PROPERTY LINE                           |
| ADJ     | ADJUSTABLE              | ELEV  | ELEVATION                     | INSUL   | INSULATE(D)                 | PLYWD    | PLYWOOD  |
| ADU     | ACCESSORY DWELLING UNIT | EQ    | EQUIPMENT                     | INT     | INTERIOR                    | PANL     | PANEL  |
| AFF     | FLOOR ABOVE FINISH      | EQ    | EQUAL                         | JAN     | JANITORS CLOSET             | PNT      | PAINT  |
| ALUM    | ALUMINUM                | (E)   | EXISTING                      | JST     | JOIST                       | PR       | PAIR   |
| ALT     | ALTERNATE               | EXST  | EXISTING                      | KIT     | KITCHEN                     | PRE-FIN  | PRE-FINISHED                                   |
| APT     | APARTMENT               | EXT   | EXTERIOR                      | LAM     | LAMINATE BOARD              | PRE-PR   | PRE-PRIMED                                     |
| ARCH    | ARCHITECT(URAL)         | FCB   | FIBER CEMENT BOARD            | LAV     | LAVATORY                    | PT       | PRESSURE TREATED                               |
| AWN     | AWNING                  | FD    | FLOOR DRAIN                   | LAUN    | LAUNDRY                     | R        | RADIUS   |
| BD      | BOARD                   | FEC   | FIRE EXTINGUISHER CABINET     | LGT     | LIGHT                       | RD       | ROOF DRAIN                                     |
| BR      | BEDROOM                 | FIN   | FINISH                        | LIN     | LINOLEUM                    | REF      | REFERENCE                                      |
| BDRM    | BEDROOM                 | FLR   | FLOOR                         | MAINT   | MAINTENANCE                 | REFR     | REFRIGERATOR                                   |
| BLDG    | BUILDING                | FND   | FOUNDATION                    | MATL    | MATERIAL                    | REQ'D    | REQUIRED                                       |
| BLKG    | BLOCKING                | FOS   | FACE OF FINISH                | MAX     | MAXIMUM                     | REST     | RESTROOM                                       |
| BLW     | BELOW                   | FOS   | FACE OF STUD                  | MECH    | MECHANICAL                  | REV      | REVISION                                       |
| BM      | BEAM                    | FOF   | FACE OF WALL                  | MEMB    | MEMBRANE                    | RM       | ROOM   |
| BO/B.O. | BOTTOM OF               | FRM   | FRAMING                       | MFR     | MANUFACTURER                | RO       | ROUGH OPENING                                  |
| BOT     | BOTTOM                  | FT    | FEET                          | MIN     | MINIMUM                     | SD       | SMOKE DETECTOR                                 |
| BSMT    | BASEMENT                | FTG   | FOOTING                       | MIR     | MIRROR                      | SF       | SQUARE FOOT                                    |
| CLG     | CEILING                 | FV    | FIELD VERIFY                  | MISC    | MISCELLANEOUS               | SHING    | SHINGING                                       |
| CLR     | CLEAR(ANCE)             | GA    | GUAGE                         | MO      | MASONRY                     | SIM      | SIMILAR  |
| CMU     | CONCRETE UNIT MASONRY   | GA    | GYPSON ASSOCIATION GALVANIZED | MTL     | METAL                       | SPEC     | SPECIFICATION                                  |
| CPT     | CARPET                  | GB    | GYPSON WALL BOARD             | (N)     | NEW                         | SS       | STAINLESS STEEL                                |
| COL     | COLUMN                  | GBW   | GYPSON WALL BOARD             | N       | NORTH                       | STD      | STANDARD                                       |
| COLS    | COLUMNS                 | HB    | HOSE BIB                      | NA      | NOT APPLICABLE              | STL      | STEEL  |
| CONC    | CONCRETE                | HDR   | HEADER                        | NR      | NON RATED                   | STOR     | STORAGE  |
| CORR    | CORRIDOR                | HDW   | HARDWARE                      | NTS     | NOT TO SCALE                | STC      | SOUND TRANSMISSION CLASS                       |
| D       | DRYER                   | HM    | HOLLOW METAL                  | OC/O.C. | ON CENTER OCCUPANT(S)       | STRUCT   | STRUCTURAL                                     |
| DBL     | DOUBLE                  | HORIZ | HORIZONTAL                    | OCC     | OCCUPANT(S)                 | T & G    | TONGUE & GROOVE                                |
| DIA     | DIAMETER                | HR    | HOUR                          | OLF     | OCCUPANCY(IES) FACTOR       | TB       | TOWEL BAR                                      |
| DIM     | DIMENSION               | HVAC  | HVAC                          | OPP     | OPPOSITE                    | THK      | THICK, THICKNESS                               |
| DN      | DOWN                    |       |                               | ORD     | OVERFLOW ROOF DRAIN         | TOV.T.O. | TOP OF VENTILATION AND AIR CONDITIONING        |
| DR      | DRYER                   |       |                               |         |                             | TP       | TOILET PAPER TYPICAL                           |
| DS      | DOWNSPOUT               |       |                               |         |                             | UL       | UNDERWRITERS LABORATORY UNLESS NOTED OTHERWISE |
| DW      | DISHWASHER              |       |                               |         |                             | UNO      | UNLESS NOTED OTHERWISE                         |
| DWG     | DRAWING                 |       |                               |         |                             | VERT     | VERTICAL                                       |
|         |                         |       |                               |         |                             | VS       | VERSUS   |
|         |                         |       |                               |         |                             | W        | WASHER   |
|         |                         |       |                               |         |                             | WC       | WATER CLOSET                                   |
|         |                         |       |                               |         |                             | WD       | WOOD   |
|         |                         |       |                               |         |                             | WH       | WATER HEATER                                   |
|         |                         |       |                               |         |                             | WRB      | WEATHER RESISTIVE BARRIER                      |
|         |                         |       |                               |         |                             | WP       | WATERPROOF                                     |
|         |                         |       |                               |         |                             | WR       | WATER RESISTANT                                |

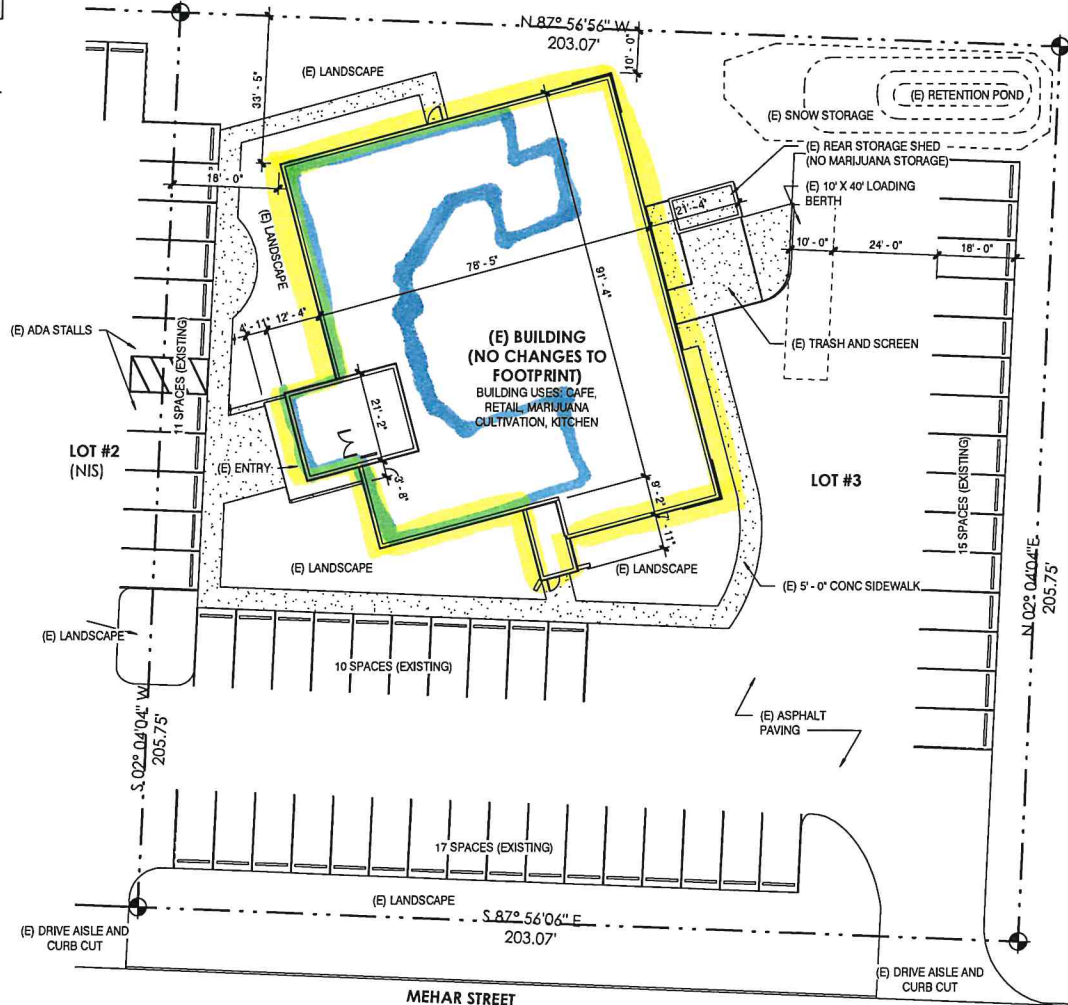

1 SITE PLAN  
A0.0 SCALE: 3/8" = 1'-0"



PERMIT SET REVISIONS (REFERENCE ONLY)

Good Titrations License # 20827  
506 Merhar Avenue Fairbanks, AK Retail

| # | Date | Description |
|---|------|-------------|
| 1 |      |             |

09.09.19 Date  
SM Drawn By

Project Info, Zoning / Code, & Site Plan

A0.0  
Copyright 2019 ©  
If this drawing is less than 22" x 34", it has been reduced. Scale accordingly. Half size at 11" x 17".

AMCO Received 2/24/2020



Diagram 4

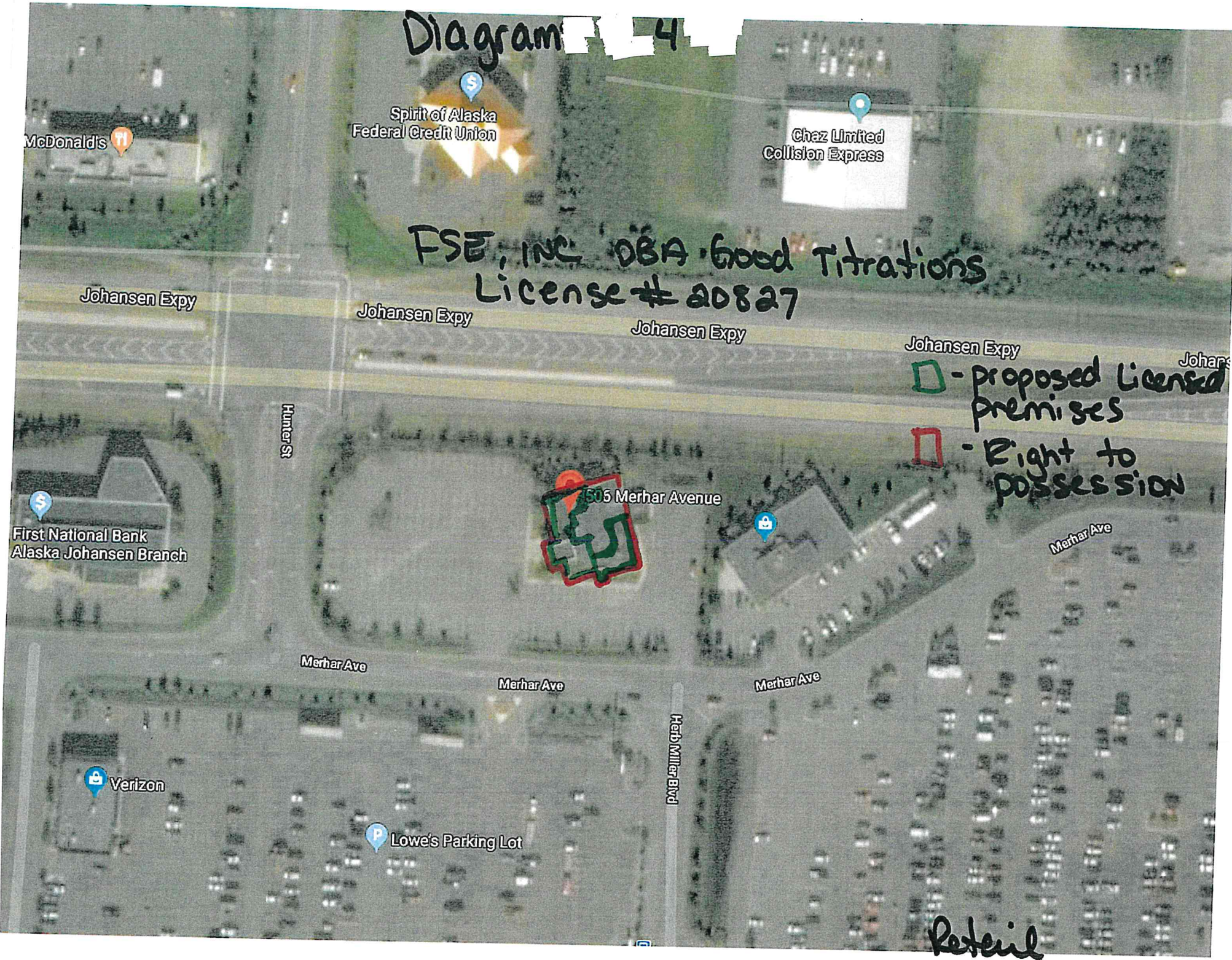





# MEMORANDUM

City of Fairbanks Clerk's Office

D. Danyielle Snider, City Clerk

---

TO: Mayor Jim Matherly and City Council Members

FROM: D. Danyielle Snider, CMC, City Clerk 

SUBJECT: Application for New Standard Marijuana Cultivation Facility License

DATE: April 7, 2020

---

Attached you will find a notification from the Alcohol and Marijuana Control Office (AMCO) of an application for a new Standard Marijuana Cultivation Facility License and additional information for the following applicant:

License #: **20829**  
License Type: **Standard Marijuana Cultivation Facility**  
D.B.A.: Good Titrations  
Licensee/Applicant: FSE, Inc.  
Physical Location: 506 Merhar Avenue, Fairbanks, Alaska

Pursuant to FGC Sec. 14-214 and 3 AAC 306.060, the Council must determine whether to protest the marijuana license application after holding a public hearing.

A notice of the date, time, and place of the public hearing has been mailed to all property owners within 1,000 feet of the proposed cultivation facility, and notice of the public hearing will be advertised in the Fairbanks Daily News Miner on Friday, April 10, 2020.

The the Police Department has included a one-year call report for the location, but Chief Reeder is not recommending protest. The Building and Fire Departments are recommending protest until construction is complete and a Certificate of Occupancy is issued. There are no other departmental objections to the issuance of the license.

# CITY OF FAIRBANKS PUBLIC SAFETY

## Good Titrations 506 Merhar Ave

04/01/2019 - 03/30/2020

| Report # | Call Time        | Nature           | Location       | Prime Unit | Disp. | Close Time          |
|----------|------------------|------------------|----------------|------------|-------|---------------------|
|          | 01/18/2020 15:07 | URGENT WELFARE   | 506 MERHAR AVE | O50        | NRP   | 01/18/2020 15:37:46 |
|          | 01/13/2020 14:35 | TRESPASS/UNWANTE | 506 MERHAR AVE | O13        | NRP   | 01/13/2020 15:24:14 |
|          | 01/03/2020 15:33 | SUSP             | 506 MERHAR AVE | S6         | NRP   | 01/03/2020 15:47:38 |
|          | 06/08/2019 17:56 | ALARM BURGLARY - | 506 MERHAR AVE | S3         | FAB   | 06/08/2019 18:13:43 |
|          | 05/22/2019 11:11 | ALARM BURGLARY - | 506 MERHAR AVE | O3         | FAB   | 05/22/2019 11:40:46 |

Total Number of Events Listed: 5





# City of Fairbanks

Office of the City Clerk

800 Cushman Street

Fairbanks, AK 99701

(907)459-6715

Fax (907)459-6710

## ALCOHOL AND MARIJUANA CONTROL OFFICE MARIJUANA LICENSE RESPONSE FORM

- TO:  FINANCE DEPARTMENT  
 BUILDING DEPARTMENT  
 FIRE DEPARTMENT  
 POLICE DEPARTMENT

DATE: 03/03/2020

FROM: CITY CLERK'S OFFICE

RE: MARIJUANA LICENSE ACTION – NEW STANDARD CULTIVATION APPLICATION

DATE NOTICE RECEIVED AT CLERKS OFFICE: 03/03/2020 (60 DAY DUE DATE 05/01/2020)

DATE RESPONSE DUE: **04/07/2020** for City Council Meeting of 04/13/2020

License #: 20829  
 License Type: Standard Marijuana Cultivation Facility  
 D.B.A.: Good Titrations  
 Licensee/Applicant: FSE, Inc.  
 Physical Location: 506 Merhar Avenue, Fairbanks, Alaska

| Corp/LLC Agent:            | Mailing Address                        | Phone        | Date and State of Ltd/Partner/Corp | Good Standing? |
|----------------------------|--|--------------|------------------------------------|----------------|
| FSE, Inc.<br>Frank Berardi | 801 Pelican Way<br>Fairbanks, AK 99709 | 907-231-2943 | 01/14/2015 – AK                    | Yes            |

Please note: Members/Officers/Directors listed below are the principal members. There may be additional shareholders. All members who hold at least 10% shares are listed.

| Member/Officer/Affiliate: | Mailing Address                                    | Phone        | Title/Shares (%)  |
|---------------------------|--|--------------|---|
| Brandon Emmett            | 1299 Lowbush Lane<br>Fairbanks, AK 99709           | 907-328-8529 | Vice President/Director/Secretary/<br>Shareholder – 25% |
| Frank Berardi             | 801 Pelican Way<br>Fairbanks, AK 99709             | 907-231-2943 | President/Director/Shareholder – 25%                    |
| Shaun Tacke               | 1770 Donald Avenue, Suite B<br>Fairbanks, AK 99701 | 907-978-7647 | Treasurer/Director/Shareholder – 25%                    |

### ADDITIONAL COMMENTS:

NO PROTEST:  
COMMENTS

PROTEST  
REASONS:

UNTIL CERTIFICATE OF OCCUPANCY  
IS ISSUED

DEPARTMENT SIGNEE:

(Signature)

CLEMENS PLOOTEN  
(Printed Name)

NOTE: THIS COMPLETED FORM MUST BE RETURNED TO THE CITY CLERK'S OFFICE  
BY THE DATE INDICATED ABOVE. YOU MAY E-MAIL OR FAX (459-6710) THE FORM.  
IF YOU HAVE ANY QUESTIONS CALL OUR OFFICE AT 459-6774. THANK YOU.



# City of Fairbanks

Office of the City Clerk

800 Cushman Street

Fairbanks, AK 99701

(907)459-6715  
Fax (907)459-6710

## ALCOHOL AND MARIJUANA CONTROL OFFICE MARIJUANA LICENSE RESPONSE FORM

- TO:  FINANCE DEPARTMENT  
 BUILDING DEPARTMENT  
 FIRE DEPARTMENT  
 POLICE DEPARTMENT

DATE: 03/03/2020

FROM: CITY CLERK'S OFFICE

RE: MARIJUANA LICENSE ACTION – NEW STANDARD CULTIVATION APPLICATION

DATE NOTICE RECEIVED AT CLERKS OFFICE: 03/03/2020 (60 DAY DUE DATE 05/01/2020)

DATE RESPONSE DUE: **04/07/2020** for City Council Meeting of 04/13/2020

License #: 20829  
License Type: Standard Marijuana Cultivation Facility  
D.B.A.: Good Titrations  
Licensee/Applicant: FSE, Inc.  
Physical Location: 506 Merhar Avenue, Fairbanks, Alaska

| Corp/LLC Agent:            | Mailing Address                        | Phone        | Date and State of Ltd/Partner/Corp | Good Standing? |
|----------------------------|--|--------------|------------------------------------|----------------|
| FSE, Inc.<br>Frank Berardi | 801 Pelican Way<br>Fairbanks, AK 99709 | 907-231-2943 | 01/14/2015 – AK                    | Yes            |

Please note: Members/Officers/Directors listed below are the principal members. There may be additional shareholders. All members who hold at least 10% shares are listed.

| Member/Officer/Affiliate: | Mailing Address                                    | Phone        | Title/Shares (%)  |
|---------------------------|--|--------------|---|
| Brandon Emmett            | 1299 Lowbush Lane<br>Fairbanks, AK 99709           | 907-328-8529 | Vice President/Director/Secretary/<br>Shareholder – 25% |
| Frank Berardi             | 801 Pelican Way<br>Fairbanks, AK 99709             | 907-231-2943 | President/Director/Shareholder – 25%                    |
| Shaun Tacke               | 1770 Donald Avenue, Suite B<br>Fairbanks, AK 99701 | 907-978-7647 | Treasurer/Director/Shareholder – 25%                    |

### ADDITIONAL COMMENTS:

- NO PROTEST:  
COMMENTS
- PROTEST  
REASONS: Construction and Certificate of Occupancy incomplete

DEPARTMENT SIGNEE:

James M. Styers  
(Signature)

James M. Styers  
(Printed Name)

NOTE: THIS COMPLETED FORM MUST BE RETURNED TO THE CITY CLERK'S OFFICE BY THE DATE INDICATED ABOVE. YOU MAY E-MAIL OR FAX (459-6710) THE FORM. IF YOU HAVE ANY QUESTIONS CALL OUR OFFICE AT 459-6774. THANK YOU.

# Alcohol & Marijuana Control Office

**License Number:** 20829

**License Status:** New

**License Type:** Standard Marijuana Cultivation Facility

**Doing Business As:** GOOD TITRATIONS

**Business License Number:** 1040494

**Designated Licensee:** Shaun Tacke

**Email Address:** shaun@goodtitrations.com

**Local Government:** Fairbanks (City of)

**Community Council:**

**Latitude, Longitude:** 64.858000, -147.694000

**Physical Address:** 506 Merhar Ave  
Fairbanks, AK 99701  
UNITED STATES

### Licensee #1

**Type:** Entity

**Alaska Entity Number:** 10026238

**Alaska Entity Name:** FSE, Inc.

**Phone Number:** 907-978-7647

**Email Address:** shaun@goodtitrations.com

**Mailing Address:** 1770 Donald Ave  
Suite B  
Fairbanks, AK 99701  
UNITED STATES

### Entity Official #1

**Type:** Individual

**Name:** Jeffrey Weltzin

**Phone Number:** 907-590-1305

**Email Address:** jeffreyweltzin@gmail.com

**Mailing Address:** 3844 Ullrbahn Rd  
Fairbanks, AK 99709  
UNITED STATES

### Entity Official #2

**Type:** Entity

**Alaska Entity Number:** 10039028

**Alaska Entity Name:** U.N.ME, LLC

**Phone Number:** 662-694-9025

**Email Address:** mbroach1@gmail.com

**Mailing Address:** 607 Old Steese Hwy  
Ste B209  
Fairbanks, AK 99701  
UNITED STATES

### Entity Official #3

**Type:** Individual

**Name:** Judy Bath

**Phone Number:** 907-488-9451

**Email Address:** jkbath@hotmail.com

**Mailing Address:** 545 Freeman Rd  
North Pole, AK 99705  
UNITED STATES

### Entity Official #4

**Type:** Individual

**Name:** Brandon Emmett

**Phone Number:** 907-328-8529

**Email Address:** emmett@goodtitrations.com

**Mailing Address:** 1299 Lowbush Lane  
Fairbanks, AK 99709  
UNITED STATES

### Entity Official #5

**Type:** Individual

**Name:** Melissa Cervantes

**Phone Number:** 662-694-9025

**Email Address:** mbroach1@gmail.com

**Mailing Address:** 607 Old Steese Hwy  
Ste B209  
Fairbanks, AK 99701  
UNITED STATES

**Entity Official #6**

**Type:** Individual

**Name:** Frank Berardi

[REDACTED]

[REDACTED]

**Phone Number:** 907-231-2943

**Email Address:** frankberardi185@gmail.com

**Mailing Address:** 801 Pelican Way  
Fairbanks, AK 99709  
UNITED STATES

**Entity Official #7**

**Type:** Individual

**Name:** Shaun Tacke

[REDACTED]

[REDACTED]

**Phone Number:** 907-978-7647

**Email Address:** shaun@goodtitrations.com

**Mailing Address:** PO Box 82011  
Fairbanks, AK 99708  
UNITED STATES

**Entity Official #8**

**Type:** Individual

**Name:** Dawson Carroll

[REDACTED]

[REDACTED]

**Phone Number:** 907-687-6097

**Email Address:** dawsoncarroll74@yahoo.com

**Mailing Address:** 163 Carlyle Way  
Fairbanks, AK 99709  
UNITED STATES

**Entity Official #9**

**Type:** Individual

**Name:** Seth Hawkins

[REDACTED]

[REDACTED]

**Phone Number:** 907-347-4372

**Email Address:** sethhawkins@hotmail.com

**Mailing Address:** PO Box 70018  
Fairbanks, AK 99707  
UNITED STATES

**Entity Official #10**

**Type:** Individual

**Name:** Billie Jo Gehring

[REDACTED]

[REDACTED]

**Phone Number:** 907-359-2246

**Email Address:** billiejogehring@gmail.com

**Mailing Address:** PO Box 226  
Unalaska, AK 99685  
UNITED STATES

**Entity Official #11**

**Type:** Individual

**Name:** Lynn Crane

[REDACTED]

[REDACTED]

**Phone Number:** 907-581-3248

**Email Address:** unakwoman@yahoo.com

**Mailing Address:** PO Box 626  
Unalaska, AK 99685  
UNITED STATES

**Entity Official #12**

**Type:** Individual

**Name:** Joanne Ellsworth

[REDACTED]

[REDACTED]

**Phone Number:** 907-451-9401

**Email Address:** dickells74@gmail.com

**Mailing Address:** 2581 Goldstream Rd  
Fairbanks, AK 99709  
UNITED STATES

**Entity Official #13**

**Type:** Individual

**Name:** Martin Tacke

[REDACTED]

[REDACTED]

**Phone Number:** 907-460-2472

**Email Address:** marty.tacke@gmail.com

**Mailing Address:** 1770 Donald Ave  
Fairbanks, AK 99701  
UNITED STATES

**Entity Official #14**

**Type:** Individual

**Name:** Naomi Johnson

[REDACTED]

[REDACTED]

**Phone Number:** 907-388-0446

**Email Address:** naomiraven.nj@gmail.com

**Mailing Address:** 100 10th Ave  
Apt 2B6  
Fairbanks, AK 99701  
UNITED STATES

**Entity Official #15**

**Type:** Individual

**Name:** Craig O'Donoghue

[REDACTED]

[REDACTED]

**Phone Number:** 907-378-3645

**Email Address:** fairbanksdentist@gmail.com

**Mailing Address:** 4740 Villanova Dr  
#A  
Fairbanks, AK 99709  
UNITED STATES

**Entity Official #16**

**Type:** Individual

**Name:** Curtis Franklin

[REDACTED]

[REDACTED]

**Phone Number:** 907-322-7945

**Email Address:** curtfran68@gmail.com

**Mailing Address:** 3760 Mitchell Ave  
Fairbanks, AK 99709  
UNITED STATES

**Entity Official #17**

**Type:** Individual

**Name:** Joshua Spence

[REDACTED]

[REDACTED]

**Phone Number:** 907-488-1823

**Email Address:** spencej@live.com

**Mailing Address:** 2296 Outside Blvd  
North Pole, AK 99705  
UNITED STATES

**Entity Official #18**

**Type:** Individual

**Name:** Michael Cervantes

[REDACTED]

[REDACTED]

**Phone Number:** 907-460-2704

**Email Address:** michael@goodtitrations.com

**Mailing Address:** 607 Old Steese Hwy  
Ste B209  
Fairbanks, AK 99701  
UNITED STATES

**Note:** No affiliates entered for this license.



## Alaska Marijuana Control Board Operating Plan Supplemental Form MJ-04: Marijuana Cultivation Facility

### What is this form?

This operating plan supplemental form is required for all applicants seeking a marijuana cultivation facility license and must accompany **Form MJ-01: Marijuana Establishment Operating Plan**, per 3 AAC 306.020(b)(11). Applicants should review **Chapter 306: Article 4** of the **Alaska Administrative Code**. This form will be used to document how an applicant intends to meet the requirements of the statutes and regulations.

If your business has a formal operating plan, you may include a copy of that operating plan with your application, but all fields of this form must still be completed per 3 AAC 306.020 and 3 AAC 306.420(2).

### What additional information is required for cultivation facilities?

Applicants must identify how the proposed establishment will comply with applicable regulations regarding the following:

- Prohibitions
- Cultivation plan
- Waste disposal
- Odor control
- Testing procedure and protocols
- Packaging and labeling

**This form must be completed and submitted to AMCO's main office before any new or transfer application for a standard marijuana cultivation facility or limited marijuana cultivation facility license will be considered complete.**

### Section 1 – Establishment Information

Enter information for the business seeking to be licensed, as identified on the license application.

|                    |   |               |        |      |       |
|--------------------|---|---------------|--------|------|-------|
| Licensee:          | FSE, Inc                                | MJ License #: | 20829  |      |       |
| License Type:      | Standard Marijuana Cultivation Facility |               |        |      |       |
| Doing Business As: | GOOD TITRATIONS                         |               |        |      |       |
| Premises Address:  | 506 Merhar Ave                          |               |        |      |       |
| City:              | Fairbanks                               | State:        | Alaska | ZIP: | 99701 |





Section 2 – Overview of Operations

2.1. Provide an overview of your proposed facility’s operations. Include information regarding the flow of marijuana from seed or clone to harvest and transfer from your premises:

All Marijuana cultivated at Good Titrations will be tracked from seed or clone to sale or destruction in METRC. All plants that reach eight inches will be tagged and assigned a tracking number. Marijuana will be harvested and grouped into batches up to five pounds of individual strains and will be assigned a METRC harvest batch number. A random sample will be collected from each batch and sent to a licensed testing facility. The remainder of the batch will be segregated until the testing results are received. A transport manifest generated from METRC will be sent with each transfer of marijuana to another licensed facility. Marijuana will be sealed in not more than five-pound containers inside a locked storage compartment within the vehicle for wholesale transactions and up to one once containers for re-sale by retailers without re-packaging. Package labels will include, (1) the name and license number cultivation facility, (2) the date the marijuana was harvested, (3) the harvest batch number assigned to the marijuana,(4) the date the marijuana was packaged, (5) the net weight and the quality of usable marijuana packaged in a standard of measure compatible with the inventory tracking system,(6) a complete list of all pesticides, fungicides, and herbicides used in the cultivation of the marijuana.

Section 3 – Prohibitions

Review the requirements under 3 AAC 306.405 and 3 AAC 306.410.

3.1. I certify that the marijuana cultivation facility will not:

Initials

a. sell, distribute, or transfer any marijuana or marijuana product to a consumer, with or without compensation;

ST

b. allow any person, including a licensee, employee, or agent, to consume marijuana or marijuana product on the licensed premises or within 20 feet of the exterior of any building or outdoor cultivation facility; or

ST

c. treat or otherwise adulterate marijuana with any organic or nonorganic chemical or compound to alter the color, appearance, weight, or odor of the marijuana.

ST

Section 4 – Cultivation Plan

Review the requirements under 3 AAC 306.420 and 3 AAC 306.430.

4.1. Describe the size of the space(s) the marijuana cultivation facility intends to be under cultivation, including dimensions and overall square footage. Provide your calculations below:

The proposed premises area under cultivation is broken into bloom/flowering areas, cloning/mother areas, and vegetative areas.

Below is the breakdown:

The Veg/Clone/Mother area is 480 square feet in area under cultivation. The room dimensions are 9' 11 3/4" W x 15' 8 3/4" L. The cloning/mother area is located in the same room with 125.2 square feet designated for clones and mothers.

The Bloom/Flowering room dimensions are 15'11 W X 29'5 3/4, resulting in 466.55 square feet in area under cultivation.

Total area under cultivation: 946.55



# Form MJ-04: Marijuana Cultivation Facility Operating Plan Supplemental

You must be able to certify the statement below. Read the following and then sign your initials in the box to the right: Initials

4.2. The proposed area(s) for cultivation are clearly identified on the Form MJ-02: Premises Diagram that is submitted with this application.

ST

Answer "Yes" or "No" to the following question: Yes No

4.3. Will the marijuana cultivation facility include outdoor production?

If "Yes", describe the outdoor structure(s) or the expanse of open or clear ground and how it is fully-enclosed by a physical barrier:

4.4. Describe the method(s) used to ensure that any marijuana at the marijuana cultivation facility, whether indoors or outdoors, cannot be observed by the public from outside the facility:

Good Titrations will ensure that marijuana cannot be visible by the public from any door or window to the cultivation areas. All direct access doors to outside areas will have no direct view of any marijuana or cultivation areas. Security measures will also be in place to include sensors/alarm on all windows and doors. All movement/transport of marijuana will be discrete, utilizing a designated shipping area, which will ensure discretion when a vehicle is being loaded out of sight of the public. All growing, processing, curing, packaging and labeling activities will be done inside the facility, not visible from outside. Continued..

4.5. Describe the marijuana cultivation facility's growing medium(s) to be used:

Roots to water, COCO, and Dirt. Recirculating and drip feed.

4.6. Provide the complete product name and EPA registration # (if applicable) for each of the cultivation facility's pesticide and pest control product to be used. All proposed products must be on DEC's list of approved pesticides in the state of Alaska:

Mint concentrate and all items listed on DEC approved list.

4.7. Describe all other fertilizers, chemicals, gases, and delivery systems, including carbon dioxide management, to be used at the marijuana cultivation facility:

Powdered and liquid plant nutrients. Nutrients will be hand mixed then distributed to appropriate reservoir to be either drip fed or recirculated threw roots. These systems will be pump and gravity fed. No CO2 will be used. Hydrogen peroxide, alcohol, and bleach products for cleaning.



# Form MJ-04: Marijuana Cultivation Facility Operating Plan Supplemental

4.8. Describe the marijuana cultivation facility's irrigation and waste water systems to be used:

Good Titrations will be utilizing a drain to waste drip irrigation system; waste water will be piped to the main sewer line.

## Section 5 – Waste Disposal

Review the requirements under 3 AAC 306.740.

You must be able to certify the statement below. Read the following and then sign your initials in the box to the right: Initials

5.1. The marijuana cultivation facility shall give the board at least three days written notice required under 3 AAC 306.740(c) before making marijuana waste unusable and disposing of it.

ST

5.2. Describe how you will store, manage, and dispose of any solid or liquid marijuana waste, including wastewater generated during marijuana cultivation, in compliance with any applicable laws. Include details about the material(s) you will mix with ground marijuana waste and the processes that you will use to make the marijuana waste unusable for any purpose for which it was grown:

Good Titrations will be disposing of: (1) marijuana that is identified as contaminated, infected or is otherwise rejected for quality or fails to meet quality testing, (2) waste from marijuana flower, plant material and trimmings, (3) run off water from cultivation and processing, (4) any other materials or containers in contact with marijuana that risks contamination, (5) any other marijuana deemed as waste by the MCB or director. Marijuana waste will be stored away from all other marijuana, on site, in sealed commercial grade containers under video surveillance. A notice via email will be sent out to AMCO enforcement not later than three (3) days prior to rendering any waste unusable and will be recorded in METRC when that function becomes available. Marijuana waste will be rendered unusable by grinding and then mixing with other compostable and non-compostable material such as, food waste, yard waste, cardboard, paper and soil; until the resulting mixture is no more than fifty percent (50%) marijuana waste. Management will maintain a log on the status of all marijuana waste, tracking the type, date of disposal, reason for disposal, date it was rendered unusable, and final destination. A waste truck will collect the waste mixture and dispose of it at the local waste station. This information will be recorded in the disposal log and security stored as a business record, available to AMCO upon request. Records of all waste material transfers will be kept for a minimum of three years for view upon request by authorized authorities.





**Section 6 – Odor Control**

Review the requirements under 3 AAC 306.430.

Answer "Yes" or "No" to the following question:

Yes No

6.1. Have you received an exemption from your local government for the odor control requirement set forth in 3 AAC 306.430(c)(2)?

Yes  No

If "Yes", you must be able to certify the statement below. Read the following and then sign your initials in the box:

Initials

I am attaching to this form documentation of my odor control exemption from the local government.

If "No" to question 6.1., describe the odor control method(s) to be used and how the marijuana cultivation facility will ensure that any marijuana at the facility does not emit an odor that is detectable by the public from outside the facility:

[Empty text box for odor control description]

**Section 7 – Testing Procedure and Protocols**

Review the requirements under 3 AAC 306.455 and 3 AAC 306.465.

You must be able to certify each statement below. Read the following and then sign your initials in the corresponding box:

Initials

7.1. I understand and agree that the board or director will, from time to time, require the marijuana cultivation facility to provide samples of the growing medium, soil amendments, fertilizers, crop production aids, pesticides, or water for random compliance checks.

ST

7.2. I will ensure that any individual responsible for collecting random, homogenous samples for required laboratory testing under 3 AAC 306.455 will prepare the necessary accompanying signed statement, provide the signed statement to the marijuana testing facility, and maintain a copy as a business record under 3 AAC 306.755.

ST

7.3. Describe the testing procedures and protocols the marijuana cultivation facility will follow:

All harvested marijuana will be processed into batches of five pounds. Licensees or a designated employee will collect a testing sample at random from each batch. The individual responsible for collection will prepare a signed statement attesting that each sample was randomly selected, provide a signed statement to the testing facility, and maintain a copy as a business record. Good Titrations will transport all samples to a licensed testing facility in compliance with the state regulations and the company's transportation policies. The cultivation facility will ensure that any individual transporting marijuana has a valid marijuana handler permit issued by AMCO. While awaiting the testing results, the remainder of the batch will be segregated in a secured quarantine area. The facility will maintain all testing results as part of its official business records, and will enter the results in METRC. Good Titrations will comply with any request from AMCO for a random sample from any growing medium, soil amendment, fertilizer, crop production aid, pesticide, or water and shall bear the expense for all such requests.





Section 8 – Packaging and Labeling

Review the requirements under 3 AAC 306.470 and 3 AAC 306.475.

Answer "Yes" or "No" to the following question:

Yes No

8.1. Will the marijuana cultivation facility be packaging marijuana for a retail marijuana store to sell to a consumer without repackaging?

If "Yes", describe how the marijuana cultivation facility will ensure that the marijuana sold will meet the packaging requirements in 3 AAC 306.470, and provide a sample label that the facility will use to meet the labeling requirements set forth in 3 AAC 306.475:

Marijuana will be packaged for retail in packages not exceeding one ounce without additional handling by the retail store except to place their own label and logo on the package. The shipping container will have a label stating that a licensed testing facility has tested each batch in the shipment, and list: (1) the date of final testing; (2) the cannabinoid potency profile, expressed as a range of percentages that extends from the lowest percentage to highest percentage of concentration for each cannabinoid listed from every test conducted on that strain of marijuana from the same marijuana cultivation facility within the last three months; (3) a statement listing the results of microbial testing; and (4) a statement listing the contaminants for which the marijuana was tested, including molds, mildew, filth, herbicides, pesticides, fungicides, and harmful chemicals. Any packaging done at the facility will be performed in an area specifically set aside for packaging and monitored with 24 hour surveillance. Packaging will be uniform with labels secure and prominently displayed. Continued..

Answer "Yes" or "No" to the following question:

Yes No

8.2. Will the marijuana cultivation facility be packaging marijuana in wholesale packages?

If "Yes", describe how the marijuana cultivation facility will ensure that the marijuana sold will meet the packaging requirements in 3 AAC 306.470, and provide a sample label that the facility will use to meet the labeling requirements set forth in 3 AAC 306.475:

Wholesale packages of marijuana will be sold to other licensed facilities in packages up to ten pounds consisting of a single strain or a mixture of strains with strain names identified on the label. Plastic packaging will be heat-sealed without an easy-open tab, dimple, corner, or flap. Packaged marijuana will be stored in a secured area until ready for transport. All packaging will be inspected, accepted or rejected, and recorded in the log, and the on site manager, or a licensee will check all final packages to ensure that they will secure marijuana from contamination and not impart toxic or deleterious substances. Wholesale labels will be checked for (1) the date of final testing; (2) the cannabinoid potency profile, expressed as a range of percentages that extends from the lowest percentage to highest percentage of concentration for each cannabinoid listed from every test conducted on that strain of marijuana from the same marijuana cultivation facility within the last three months; Continued

I certify that as a marijuana cultivation facility, I will submit monthly reports to the Department of Revenue and pay the excise tax required under AS 43.61.010 and AS 43.61.020 on all marijuana sold or provided as a sample to a marijuana establishment, as required under 3 AAC 306.480.

I declare under penalty of unsworn falsification that this form, including all accompanying schedules and statements, is true, correct, and complete.

Signature of licensee: [Handwritten Signature]
Printed name of licensee: Shaun Tacke

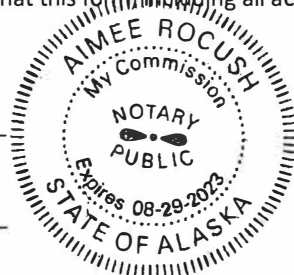

Notary Public in and for the State of Alaska: [Handwritten Signature]
My commission expires: 8/29/2023

Subscribed and sworn to before me this 20 day of December, 2019.



(Additional Space as Needed):

4.4 Continued: All marijuana will be securely packaged, labeled and organized for transport within the facility before being moved to the transport vehicle.

8.1 Continued: The facility will use certified scales in compliance with the Alaska Weights and Measures Act, and will maintain registration and inspection reports at the facility. After agents package marijuana they will be placed in sanitized, air-tight containers, labeled with all compliant labeling information, and be given a bar-code for the inventory control system. Plastic packaging will be heat-sealed without an easy-open tab, dimple, corner, or flap. Packaged marijuana will be stored in a secured area until ready for transport. All packaging will be inspected, accepted or rejected, and recorded in the log, Licensees, and/or the on site manager will check all final packages to ensure that they will secure marijuana from contamination and not impart toxic or deleterious substances, and no images that appeal to children, such as cartoons or similar images, will be on the packaging. Labels will include: (1) the name and license number of the cultivation facility; (2) the date the marijuana was harvested; (3) the harvest batch number assigned to the marijuana; (4) the date the marijuana was packaged; (5) the net weight and the quantity of usable marijuana packaged in a standard of measure compatible with the inventory tracking system; (6) a complete list of all pesticides, fungicides, and herbicides used in the cultivation of the marijuana. The facility will use certified scales in compliance with the Alaska Weights and Measures Act, and will maintain registration and inspection reports at the facility.

8.2 Continued: (3) a statement listing the results of microbial testing; and (4) a statement listing the contaminants for which the marijuana was tested, including molds, mildew, filth, herbicides, pesticides, fungicides, and harmful chemicals. A METRC generated tracking label will be affixed to each package. The shipping container will have a label stating that a licensed testing facility has tested each batch in the shipment, and list: (1) the date of final testing; (2) the cannabinoid potency profile, expressed as a range of percentages that extends from the lowest percentage to highest percentage of concentration for each cannabinoid listed from every test conducted on that strain of marijuana from the same marijuana cultivation facility within the last three months; (3) a statement listing the results of microbial testing; and (4) a statement listing the contaminants for which the marijuana was tested, including molds, mildew, filth, herbicides, pesticides, fungicides, and harmful chemicals. If a wholesale shipment sold to another licensed facility is from a harvest batch that has not been tested for contaminants, a label will be affixed identifying each such contaminant.

|   |  |  |
|---|--|--|
| <b>Retailer:</b>  | <b>License No:</b>                                       |  |
| <b>Cultivator:</b> Good Titrations                            | <b>License No:</b> 23455                                 |  |
| <b>Harvest Batch No:</b>                                      | <b>Package No:</b>                                       |  |
| <b>Net MJ Weight:</b> OZ( g)                                  | <b>Strain:</b>   |  |
| <b>Testing Facility:</b>                                      | <b>License No:</b>                                       |  |
| <b>THC:</b> <b>THCA:</b> <b>CBD:</b> <b>CBDA:</b> <b>CBN:</b> |  |  |
| <b>Microbial Test:</b>  | <b>Fungicides:</b> <b>Pesticides:</b> <b>Herbicides:</b> |  |
| <b>Fertilizers:</b>   | <b>Soil Amendment:</b>                                   |  |

**Alaska Safety Warning:** Marijuana has intoxicating effects and may be habit forming and addictive. Marijuana impairs concentration, coordination and judgment. Do not operate a vehicle or machinery under its influence. There are health risks associated with consumption of marijuana. For use only by adults twenty-one and older. Keep out of the reach of children. Marijuana should not be used by women who are pregnant or breast feeding.

|   |  |                                     |   |                                 |   |                             |   |   |                   |
|---|--|-------------------------------------|---|---------------------------------|---|-----------------------------|---|---|-------------------|
| Front of Package  | Back of Package  |                                     |   |                                 |   |                             |   |   |                   |
| *window to view product*  | Cultivator: Good Titrations<br>License #20829<br>HB#: northstarvalley252018<br>Strain: North Star OG   |                                     |   |                                 |   |                             |   |   |                   |
| <u>Strain Name</u>  |  |                                     |   |                                 |   |                             |   |   |                   |
| <b>Indica-Dominant</b>  |  |                                     |   |                                 |   |                             |   |   |                   |
| Net Weight: 3.5 g (0.124 oz.)   |  |                                     |   |                                 |   |                             |   |   |                   |
| PLACE HOLDER FOR RETAILER TO PUT<br>RETAILER STICKER LABEL              | <table border="1"> <tr> <td style="text-align: center;"><b>METRC #:</b> 36887500036451115AB</td> </tr> <tr> <td style="text-align: center;"><b>Testing Lab:</b> ABC Lab    <b>License #:</b></td> </tr> <tr> <td style="text-align: center;"><b>Testing Date:</b> 02/05/2018</td> </tr> <tr> <td style="text-align: center;"><b>Fungicides:</b> None    <b>Herbicides:</b> None    <b>Pesticides:</b> None</td> </tr> <tr> <td style="text-align: center;"><b>Cannabinoid Profile:</b></td> </tr> <tr> <td style="text-align: center;"><b>Total THC:</b> XXXX%    <b>Total CBD:</b> XXXX%    <b>THC:</b> XXXX%</td> </tr> <tr> <td style="text-align: center;"><b>CBD:</b> XXXX%    <b>THC-A:</b> XXXX%    <b>CBD-A:</b> XXXX%</td> </tr> <tr> <td style="text-align: center;"><b>CBN:</b> XXXX%</td> </tr> </table> <p><small>Alaska Safety Warning: Marijuana has intoxicating effects and may be habit forming and addictive. Marijuana impairs concentration, coordination and judgment. Do not operate a vehicle or machinery under its influence. There are health risks associated with consumption of marijuana. For use only by adults twenty-one and older. Keep out of the reach of children. Marijuana should not be used by women who are pregnant or breast feeding.</small></p> | <b>METRC #:</b> 36887500036451115AB | <b>Testing Lab:</b> ABC Lab <b>License #:</b> | <b>Testing Date:</b> 02/05/2018 | <b>Fungicides:</b> None <b>Herbicides:</b> None <b>Pesticides:</b> None | <b>Cannabinoid Profile:</b> | <b>Total THC:</b> XXXX% <b>Total CBD:</b> XXXX% <b>THC:</b> XXXX% | <b>CBD:</b> XXXX% <b>THC-A:</b> XXXX% <b>CBD-A:</b> XXXX% | <b>CBN:</b> XXXX% |
| <b>METRC #:</b> 36887500036451115AB                                     |  |                                     |   |                                 |   |                             |   |   |                   |
| <b>Testing Lab:</b> ABC Lab <b>License #:</b>                           |  |                                     |   |                                 |   |                             |   |   |                   |
| <b>Testing Date:</b> 02/05/2018   |  |                                     |   |                                 |   |                             |   |   |                   |
| <b>Fungicides:</b> None <b>Herbicides:</b> None <b>Pesticides:</b> None |  |                                     |   |                                 |   |                             |   |   |                   |
| <b>Cannabinoid Profile:</b>   |  |                                     |   |                                 |   |                             |   |   |                   |
| <b>Total THC:</b> XXXX% <b>Total CBD:</b> XXXX% <b>THC:</b> XXXX%       |  |                                     |   |                                 |   |                             |   |   |                   |
| <b>CBD:</b> XXXX% <b>THC-A:</b> XXXX% <b>CBD-A:</b> XXXX%               |  |                                     |   |                                 |   |                             |   |   |                   |
| <b>CBN:</b> XXXX%   |  |                                     |   |                                 |   |                             |   |   |                   |
| *or similar format and content  |  |                                     |   |                                 |   |                             |   |   |                   |





## Alaska Marijuana Control Board Form MJ-02: Premises Diagram

### What is this form?

A detailed diagram of the proposed licensed premises is required for all marijuana establishment license applications, per 3 AAC 306.020(b)(8). **All areas designated as the licensed premises of a single license must be contiguous. All diagrams must have the licensed premises area labeled, and outlined or shaded as appropriate.**

### What must be submitted with this form?

Applicants must attach multiple diagrams to this form, including (as applicable):

- **Diagram 1:**  
a diagram showing only the licensed premises areas that will be ready to be **operational at the time of your preliminary inspection** and license issuance;
- **Diagram 2:**  
if different than Diagram 1, a diagram outlining **all areas for which the licensee has legal right of possession** (a valid lease or deed), and clearly showing those areas' relationship to the current proposed licensed premises (*details of any planned expansion areas do not need to be included; a complete copy of Form MJ-14: Licensed Premises Diagram Change must be submitted and approved before any planned expansion area may be added to the licensed premises*);
- **Diagram 3:**  
a **site plan or as-built of the entire lot**, showing all structures on the property and clearly indicating which area(s) will be part of the licensed premises;
- **Diagram 4:**  
an **aerial photo of the entire lot and surrounding lots**, showing a view of the entire property and surrounding properties, and clearly indicating which area(s) will be part of the licensed premises (*this can be obtained from sources like Google Earth*); and
- **Diagram 5:**  
a diagram of the **entire building in which the licensed premises is located**, clearly distinguishing the licensed premises from unlicensed areas and/or premises of other licenses within the building. If your proposed licensed premises is located within a building or building complex that contains multiple business and/or tenants, please provide the addresses and/or suite numbers of the other businesses and/or tenants (*a separate diagram is not required for an establishment that is designating the entire building as a single licensed premises*).

**This form, and all necessary diagrams that meet the requirements on Page 2 of this form, must be completed and submitted to AMCO's main office before any new or transfer license application will be considered complete.**

### Section 1 – Establishment Information

Enter information for the business seeking to be licensed, as identified on the license application.

|                    |   |               |        |      |       |
|--------------------|---|---------------|--------|------|-------|
| Licensee:          | FSE, Inc                                | MJ License #: | 20829  |      |       |
| License Type:      | Standard Marijuana Cultivation Facility |               |        |      |       |
| Doing Business As: | GOOD TITRATIONS                         |               |        |      |       |
| Premises Address:  | 506 Merhar Ave                          |               |        |      |       |
| City:              | Fairbanks                               | State:        | Alaska | ZIP: | 99701 |





# Diagrams 1, 2 & 5

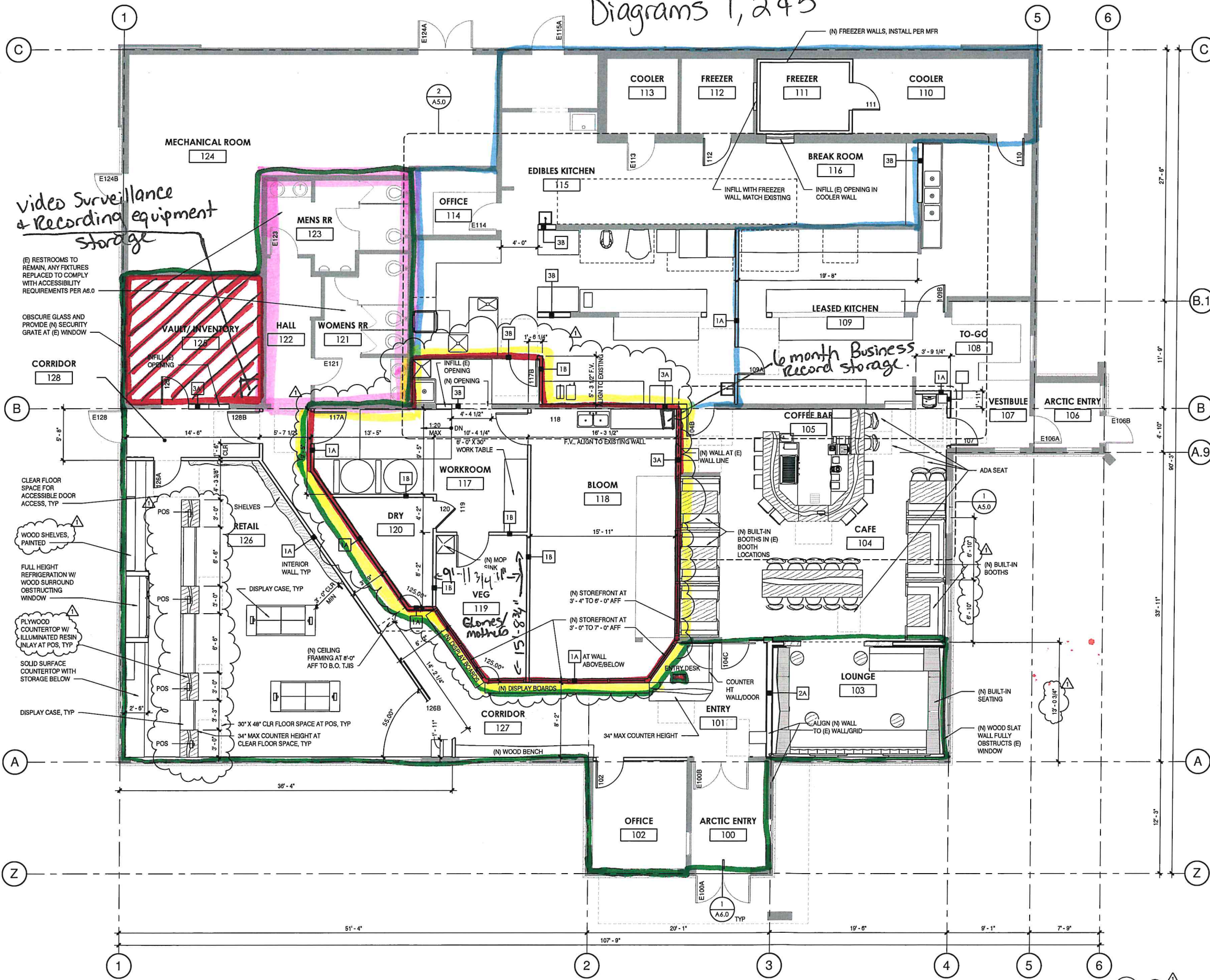

### SHEET NOTES (PLANS)

- DIMENSIONS ARE TO FACE OF STUD, FACE OF CONCRETE, GRID LINES, AND CENTER LINE OF WINDOW ASSEMBLIES UNLESS OTHERWISE NOTED.
- CONSTRUCTION ASSEMBLY DESCRIPTIONS, SEE A1.0.
- PRODUCT SPECIFICATIONS, SEE A1.0.
- ACCESSIBILITY AND ADA DETAILS, SEE A6.0.
- OPERABLE PARTS OF LIGHTING, ENVIRONMENTAL SECURITY CONTROLS AND ELECTRICAL RECEPTACLES SHALL BE MOUNTED BETWEEN 15' AND 48" ABOVE FINISHED FLOOR.
- ALL FAUCETS TO HAVE LEVER HANDLES.
- REMOVE EXISTING TILE, GRIND AND POLISH EXISTING CONCRETE, TYP THROUGHOUT. IF ANY TILE REMAINS OR IS REPLACED DURING CONSTRUCTION, VERIFY ADA COMPLIANCE AT FLOOR TRANSITION PER 2/A6.0.

### PHASING LEGEND

- EXISTING TO REMAIN
- REMOVED DURING DEMO PHASE (DEMO PLANS ONLY)
- NEW CONSTRUCTION (NEW PLANS ONLY)



PERMIT SET REVISIONS (REFERENCE ONLY)

AMCO Received 2/27/2020

- Shared
- Restricted Access AREA
- Non-Restricted Shared Restroom
- proposed Licensed premises
- visitor ID check Area
- Retail license #20827
- Manufacturing license #20832

Good Titrations License #20827  
506 Merhar Avenue Fairbanks, AK  
Cultivation

| # | Date | Description |
|---|------|-------------|
| 1 |      |             |

Floor Plan

# A2.0

Copyright 2019 ©  
If this drawing is less than 22" x 34", it has been reduced. Scale accordingly. Half size at 11"x

Plot Date: 10/14/2019 9:39:32 PM Revit File: M:\My Drive\HARKA - PROJECT Files\Good Titrations\Dispensary\Revit\Good Titrations\_Interiors\_19.10.12.rvt

1 GROUND FLOOR PLAN  
A2.0 SCALE: 3/16" = 1'-0"



# GOOD TITRATIONS

Diagram 3

## GENERAL NOTES

- CONTRACTOR SHALL VERIFY ALL EXISTING CONDITIONS AND DIMENSIONS PRIOR TO CONSTRUCTION AND SHALL NOTIFY DESIGNER OF ANY DEVIATIONS FROM DRAWINGS PRIOR TO CONTINUATION OF WORK.
- CONTRACTOR SHALL NOTIFY DESIGNER OF ANY NEED FOR DESIGN CHANGES DUE TO FIELD CONDITIONS OR OBSERVATIONS PRIOR TO CONTINUING WORK.
- WRITTEN DIMENSIONS HAVE PRECEDENCE OVER SCALED DIMENSIONS. DO NOT SCALE THE DRAWINGS.
- DIMENSIONS ARE TO FACE OF STUD, FACE OF CONCRETE, GRID LINES, AND CENTER LINE OF WINDOW ASSEMBLIES UNLESS OTHERWISE NOTED.
- SAFETY GLAZING IS REQUIRED WHERE GLASS IS WITHIN 18" OF THE FLOOR AND 24" OF DOORS. SEE 2017 ORSC SEC. R308 FOR ADDITIONAL SAFETY REQUIREMENTS.
- ALL MATERIALS AND WORK SHALL CONFORM TO ALL GOVERNING CODES AND REGULATIONS.
- ALL WORK TO BE DONE IN ACCORDANCE WITH THE LATEST CODES WITH LOCAL AMENDMENTS AND ORDINANCES AND GOOD STANDARD PRACTICE. CONTRACTOR TO COORDINATE ALL DIMENSIONS, SIZING AND OPENINGS WITH ALL TRADES. CONTRACTOR TO VERIFY ALL CONNECTOR SIZES TO INSURE PROPER FIT.
- ALL MATERIALS AND PRODUCTS SHALL BE INSTALLED IN ACCORDANCE WITH THE MANUFACTURER'S WRITTEN INSTRUCTIONS.
- FRAMING CONTRACTOR TO VERIFY ALL ROUGH OPENING SIZES AND DETAILS FOR DOORS, WINDOWS, EXHAUST, FANS, AND VENTS.
- CONTRACTOR SHALL PROVIDE ALL NECESSARY TEMPORARY BRACING, SHORING, GUYING OR OTHER MEANS TO AVOID EXCESSIVE STRESSES AND TO HOLD STRUCTURAL ELEMENTS IN PLACE DURING CONSTRUCTION.
- ARCHITECT NOT RESPONSIBLE FOR WATER PENETRATION OF EXISTING ROOFING, FLASHING, OR PARAPETS.
- WHEN WORK NOT SPECIFICALLY CALLED OUT IS REQUIRED TO COMPLETE THE PROJECT, IT SHALL BE OF THE BEST MATERIAL AND WORKMANSHIP.
- CONTRACTOR SHALL TAKE ALL THE NECESSARY PRECAUTIONARY MEASURES TO PROTECT THE PUBLIC AND ADJACENT PROPERTIES FROM DAMAGE THROUGHOUT CONSTRUCTION. CONTRACTOR ASSUMES ALL LIABILITY FOR DAMAGES INCURRED DURING CONSTRUCTION.
- CONTRACTOR SHALL ESTABLISH AND VERIFY ALL OPENINGS AND INSERTS FOR MECHANICAL, ELECTRICAL, AND PLUMBING WITH APPROPRIATE TRADES.
- THE STARTING OF WORK BY THE GENERAL CONTRACTOR OR ANY SUBCONTRACTOR SHALL BE CONSIDERED PRIMA FACIE EVIDENCE THAT THEY HAVE INSPECTED AND ACCEPTED ALL CONDITIONS INVOLVED IN THE WORK AND FIND THEM SATISFACTORY.
- CONTRACTOR SHALL TIE NEW UTILITIES INTO PRIVATE & PUBLIC LINES AS REQUIRED BY PUBLIC, PRIVATE UTILITIES OR COUNTY.
- CONTRACTOR SHALL COORDINATE WORK OF MECH. AND ELEC. SUBCONTRACTORS AND NOTIFY DESIGNER OF ANY CONFLICTS OR VARIATIONS FROM I.R.C. REQUIREMENTS. ALL WORK TO CONFORM TO ALL RELEVANT CODES AND REGULATIONS.
- CONTRACTOR SHALL BE RESPONSIBLE FOR OBTAINING ALL DEFERRED AND TRADE PERMITS.
- CONTRACTOR SHALL VERIFY AND CONFIRM ALL SIZES & DIMENSIONS PRIOR TO ORDERING.
- WHEN POSSIBLE, USE PRODUCTS MADE IN THE UNITED STATES. EXAMPLE OF A COMPREHENSIVE LIST OF PRODUCTS MADE IN THE USA CAN BE FOUND AT: <http://www.americansworking.com/buildingmaterial.html>

## ZONING INFORMATION

|  | CODE       | PROPOSED      |
|--|------------|---------------|
| MAX HEIGHT (INDOOR SMALL MARIJUANA CULTIVATION FACILITY) | 35'-0" MAX | < 35'-0"      |
| REQUIRED YARDS   | NOT REQ'D  | NO CHANGES    |
| MAX HEIGHT   | UNLIMITED  | NO CHANGES    |
| MAX LOT COVERAGE   | 100%       | NO CHANGES    |
| SMALL INDOOR CULTIVATION                                 | PERMITTED  | ACCESSORY USE |

## PARKING

RESTAURANT: 1 SPACE PER 3 SEATS; 47 SEATS / 3 = 16 SPACES  
 STORE: 1 SPACE PER 200 SF SALES AREA; 837 SF / 200 = 4 SPACES  
 ALL OTHER COMMERCIAL/INDUSTRIAL: 3 SPACES PER 4 EMPLOYEES;  
 (22 EMPLOYEES / 4) X 3 = 17 SPACES  
 ADA PARKING: 1 ADA STALL PER 50 SPACES

37 SPACES REQUIRED

## STORMWATER MANAGEMENT

NO CHANGES TO IMPERVIOUS AREA.

## BUILDING INFORMATION

| TOTAL | EXISTING | PROPOSED              |
|-------|----------|-----------------------|
|       | 7,800 SF | 7,800 SF (NO CHANGES) |

AREA OF MARIJUANA CULTIVATION FACILITY: 1,042 SF, ALL INDOOR

## SITE INFORMATION

|                   |   |
|-------------------|---|
| ADDRESS           | 506 MERHAR AVE, FAIRBANKS, AK 99701       |
| COUNTY            | FAIRBANKS NORTH STAR                      |
| LEGAL DESCRIPTION | LOT 3, TR A, BENTLEY BROTHERS SUBDIVISION |
| LOT SIZE          | .96 ACRES (41,782 sq ft)                  |
| BASE ZONE         | GU-1 (GENERAL USE)                        |

## JOB DESCRIPTION

TENANT IMPROVEMENT OF EXISTING A-2 RESTAURANT TO NON-SEPARATED MIXED OCCUPANCY A-2 CAFE AND KITCHEN, M MARIJUANA RETAIL AND F-1 SMALL INDOOR MARIJUANA CULTIVATION. NO CHANGES TO EXTERIOR ENVELOPE.

TO COMPLY WITH 2015 INTERNATIONAL BUILDING CODE AND CITY OF FAIRBANKS LOCAL AMENDMENTS TO THE 2015 INTERNATIONAL BUILDING CODE.

VALUATION: \$130,000

## VICINITY MAP

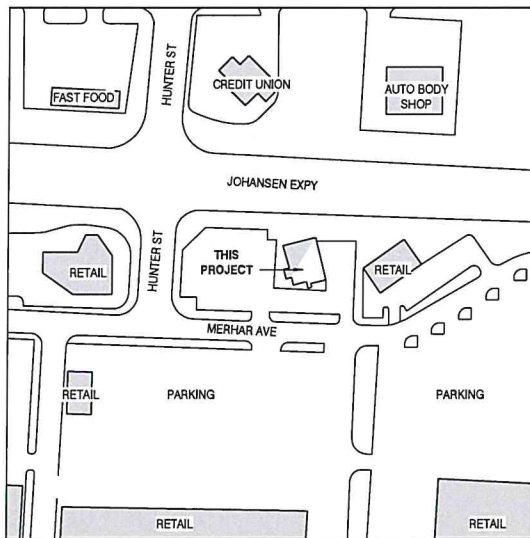

□ - Proposed Licensed Facility  
□ - Right to possession.

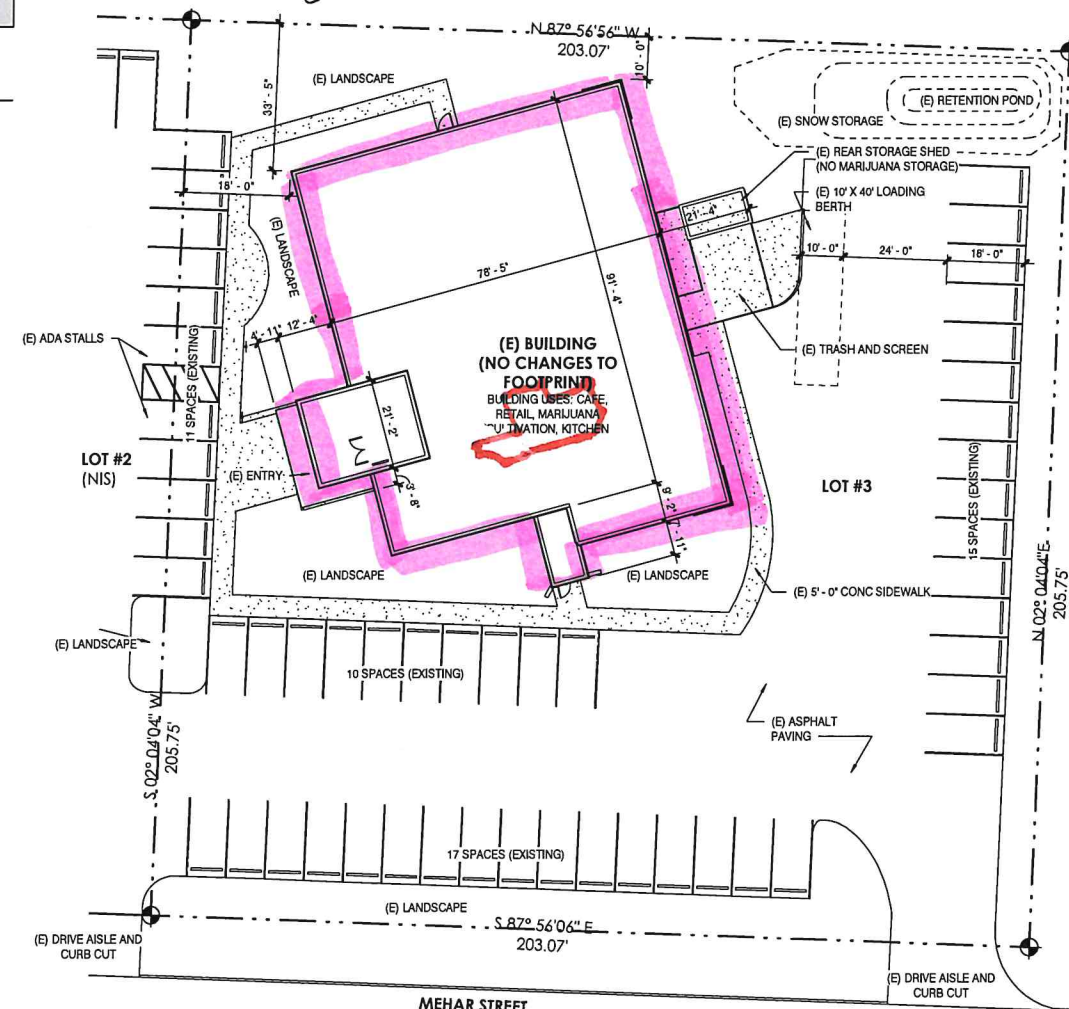

1 SITE PLAN  
 A0.0 SCALE: 3/64" = 1'-0"

## TRADE PERMITS

MECHANICAL, ELECTRICAL, PLUMBING, FIRE SPRINKLER AND SIGN PERMITS TO BE OBTAINED SEPARATELY.

## PROJECT TEAM

### OWNER

HAPPY PEPPER, LLC  
 1770 DONALD AVE  
 FAIRBANKS AK 99701  
 907-328-8529  
[info@goodtitrations.com](mailto:info@goodtitrations.com)

### ARCHITECT

HARKA ARCHITECTURE, LLC  
 107 SE WASHINGTON ST, SUITE 740  
 PORTLAND, OR 97214  
 CONTACT: PATRICK DONALDSON  
 503-975-9471  
[patrick@harkaahq.com](mailto:patrick@harkaahq.com)

### STRUCTURAL

NELSON ENGINEERING  
 155 BIDARCA STREET  
 KENAI, ALASKA 99611  
 CONTACT: ZACK RININGER  
 907-283-3583  
[ZRININGER@ALASKA.NET](mailto:ZRININGER@ALASKA.NET)

## DRAWING SHEET INDEX

### ARCHITECTURAL

- A0.0 Project Info, Zoning / Code, & Site Plan
- A0.1 Life Safety Info & Plans
- A1.0 Assemblies, Schedules & Demo Plan
- A2.0 Floor Plan
- A2.1 Reflecting Ceiling Plan
- A3.0 Elevations
- A5.0 Enlarged Plans
- A5.1 Sections & Details
- A6.0 Accessibility Details

### INTERIOR DESIGN

- ID1.0 Finish / Material Schedules & Reference Plan
- ID2.0 Fixture / Furniture Plan
- ID3.0 Lighting Plan
- ID4.0 Interior Elevations
- ID5.0 Interior Details
- ID5.1 Interior Details
- ID5.2 Interior Details

### STRUCTURAL

- S1.1 Notes and Specifications
- S1.2 Special Inspection
- S2.1 First Floor Framing Plan
- S3.1 Details

## ABBREVIATIONS

|         |                         |       |                      |         |                             |         |  |
|---------|-------------------------|-------|----------------------|---------|-----------------------------|---------|--|
| # & C   | NUMBER AND CENTERLINE   | EA    | EACH EXPANSION JOINT | IBC     | INTERNATIONAL BUILDING CODE | PERF    | PERFORATED, PERFORATE                          |
| A/C     | AIR CONDITIONING        | EJ    | ELEVATION            | IN      | INCH                        | PL      | PLASTIC LAMINATE PLATE, PROPERTY LINE          |
| ADDL    | ADDITIONAL              | EL    | ELECTRICAL           | INFO    | INFORMATION                 | PLYWD   | PLYWOOD  |
| ADJ     | ADJUSTABLE              | ELEV  | ELEVATION            | INSUL   | INSULATE(D)                 | PANEL   | PANEL  |
| ADU     | ACCESSORY DWELLING UNIT | EQUIP | ELEVATOR             | INT     | INTERIOR                    | PAINT   | PAINT  |
| AFF     | ABOVE FINISH FLOOR      | EQ    | EQUIPMENT            | JAN     | JANITORS CLOSET             | PR      | PAIR   |
| ALUM    | ALUMINUM                | EQ    | EQUIPMENT            | JST     | JOISTS                      | PRE-FIN | PRE-FINISHED                                   |
| ALT     | ALTERNATE               | EXT   | EXTERIOR             | KIT     | KITCHEN                     | PRE-PR  | PRE-PRESSED                                    |
| APT     | APARTMENT               | FCB   | FIBER CEMENT BOARD   | LAM     | LAMINATE                    | PT      | TREATED  |
| ARCH    | ARCHITECT(URAL)         | FD    | FLOOR DRAIN          | LAV     | LAVATORY                    | R       | RADIUS   |
| AWN     | AWNING                  | FEC   | FIRE EXTINGUISHER    | LAUN    | LAUNDRY                     | RD      | ROOF DRAIN                                     |
| BD      | BOARD                   | FIN   | FINISH               | LGT     | LIGHT                       | REF     | REFERENCE                                      |
| BR      | BEDROOM                 | FLR   | FLOOR                | LIN     | LINOLEUM                    | REFR    | REFRIGERATOR                                   |
| BDRM    | BEDROOM                 | FND   | FOUNDATION           | MAINT   | MAINTENANCE                 | REQ'D   | REQUIRED                                       |
| BLDG    | BUILDING                | FOF   | FACE OF FINISH       | MATL    | MATERIAL                    | REST    | RESTROOM                                       |
| BLKG    | BLOCKING                | FOF   | FACE OF FINISH       | MAX     | MAXIMUM                     | REV     | REVISION                                       |
| BLW     | BELOW                   | FOS   | FACE OF STUD         | MECH    | MECHANICAL                  | REVERSE | REVERSE  |
| BM      | BEM                     | FW    | FACE OF WALL         | MEMB    | MEMBRANE                    | RM      | ROOM   |
| BO/B.O. | BOTTOM OF               | FRM   | FRAMING              | MFR     | MANUFACTURER                | RO      | ROUGH OPENING                                  |
| BOT     | BOTTOM                  | FT    | FEET                 | MIN     | MINIMUM                     | SD      | SMOKE DETECTOR                                 |
| BSMT    | BASEMENT                | FTG   | FOOTING              | MISC    | MISCELLANEOUS               | SF      | SQUARE FOOT                                    |
| CLG     | CEILING                 | FV    | FIELD VERIFY         | MO      | MASONRY                     | SHTHG   | SHEATHING                                      |
| CLR     | CLEAR(ANCE)             | GA    | GAUGE                | MTL     | METAL                       | SIM     | SIMILAR  |
| CMU     | CONCRETE UNIT MASONRY   | GYP   | GYPSPUM              | (N)     | NEW                         | SPEC    | SPECIFICATION                                  |
| CPT     | CARPET                  | GAL   | GALVANIZED           | (N)     | NORTH                       | SS      | STAINLESS STEEL                                |
| COL     | COLUMN                  | GB    | GRAB BAR             | NA      | NOT APPLICABLE              | STD     | STANDARD                                       |
| COLS    | COLUMNS                 | GWB   | GYPSPUM WALL BOARD   | NTS     | NOT IN SCOPE                | STL     | STEEL  |
| CONT    | CONTINUOUS              | HB    | HOSE BIB             | NR      | NON RATED                   | STOR    | STORAGE  |
| CONC    | CONCRETE                | HDR   | HEADER               | NTS     | NOT TO SCALE                | STC     | SOUND TRANSMISSION CLASS                       |
| CORR    | CORRIDOR                | HDW   | HARDWARE             | OC/O.C. | ON CENTER OCCUPANT(S)       | STRUCT  | STRUCTURAL                                     |
| D       | DRYER                   | HM    | HOLLOW METAL         | OCC     | OCCUPANCY                   | T & G   | TONGUE & GROOVE                                |
| DBL     | DOUBLE                  | HORIZ | HORIZONTAL           | OLF     | OCCUPANT LOAD FACTOR        | TB      | TOWEL BAR                                      |
| DIA     | DIAMETER                | HR    | HVAC                 | OPP     | OPPOSITE                    | THK     | THICK, THICKNESS                               |
| DIM     | DIMENSION               | DWG   | DRAWING              | ORD     | OVERFLOW ROOF DRAIN         | TO/T.O. | TOP OF   |
| DN      | DOWN                    |       |                      |         |                             | TP      | TOILET PAPER                                   |
| DR      | DOOR                    |       |                      |         |                             | TYP     | TYPICAL  |
| DS      | DOWNSPOUT               |       |                      |         |                             | UL      | UNDERWRITERS LABORATORY UNLESS NOTED OTHERWISE |
| DW      | DISHWASHER              |       |                      |         |                             | UNO     | UNLESS NOTED OTHERWISE                         |
| DWG     | DRAWING                 |       |                      |         |                             | VERT    | VERTICAL                                       |
|         |                         |       |                      |         |                             | VS      | VERSUS   |
|         |                         |       |                      |         |                             | W       | WASHER   |
|         |                         |       |                      |         |                             | WC      | WATER CLOSET                                   |
|         |                         |       |                      |         |                             | WD      | WOOD   |
|         |                         |       |                      |         |                             | WH      | WATER HEATER                                   |
|         |                         |       |                      |         |                             | WIN     | WINDOW   |
|         |                         |       |                      |         |                             | WRB     | WEATHER RESISTIVE BARRIER                      |
|         |                         |       |                      |         |                             | WP      | WATERPROOF                                     |
|         |                         |       |                      |         |                             | WR      | WATER RESISTANT                                |

## LOW-CARBON NOTES

- ANNULAR SPACES AROUND PIPES, ELECTRIC CABLES, CONDUITS OR OTHER OPENINGS IN PLATES AT EXTERIOR WALLS SHALL BE PROTECTED AGAINST THE PASSAGE OF RODENTS BY CLOSING SUCH OPENINGS WITH CEMENT MORTAR, CONCRETE MASONRY OR SIMILAR ACCEPTABLE METHOD.
- A MINIMUM OF 50 PERCENT OF THE CONSTRUCTION WASTE GENERATED AT THE SITE SHALL BE DIVERTED TO RECYCLE OR SALVAGE.
- GAS FIREPLACES SHALL BE A DIRECT-VENT SEALED-COMBUSTION TYPE. WOOD/PELLET STOVES SHALL COMPLY WITH US EPA PHASE II EMISSION LIMITS.
- DUCT AND VENT OPENINGS SHALL BE COVERED DURING CONSTRUCTION.
- ADHESIVES, SEALANTS AND CAULKS SHALL BE COMPLIANT LOW OR NO VOC.
- PAINTS, STAINS, AND OTHER COATINGS SHALL BE COMPLIANT LOW OR NO VOC.
- MOISTURE CONTENT OF BUILDING MATERIALS USED IN ENCLOSED WALL AND FLOOR FRAMING IS CHECKED BEFORE ENCLOSURE AND CANNOT EXCEED 19%.
- HVAC SYSTEM INSTALLERS ARE TRAINED AND CERTIFIED IN THE PROPER INSTALLATION OF HVAC SYSTEMS.
- USE FSC, LOCAL, ENVIRONMENTALLY CERTIFIED, SUSTAINABLY-SOURCED PRODUCTS. FOR MORE INFORMATION AND RESOURCES VISIT SUSTAINABLE NW: <http://www.sustainablenorthwest.org/>
- MINIMIZE USE OF CONCRETE WHERE ALTERNATIVE IS POSSIBLE.

## SYMBOLS

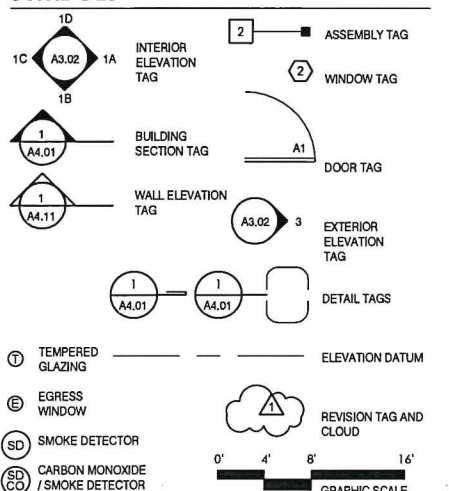

PERMIT SET REVISIONS (REFERENCE ONLY)

Good Titrations License # 08809  
 506 Merhar Avenue  
 Fairbanks, AK

| # | Date | Description |
|---|------|-------------|
| 1 |      |             |

Project Info, Zoning / Code, & Site Plan

A0.0  
 Copyright 2019 ©  
 If this drawing is less than 22" x 34", it has been reduced. Scale accordingly. Half size at 11" x 17".

AMCO Received 2/24/2020





Diagram 4

FSE, INC. DBA Good Titrations  
License # 20829

□ - Proposed Licensed premises  
□ - Right to possession

Cultivation





# MEMORANDUM

City of Fairbanks Clerk's Office

D. Danyielle Snider, City Clerk

---

TO: Mayor Jim Matherly and City Council Members  
FROM: D. Danyielle Snider, CMC, City Clerk   
SUBJECT: Application for New Marijuana Product Manufacturing Facility License  
DATE: April 7, 2020

---

Attached you will find a notification from the Alcohol and Marijuana Control Office (AMCO) of an application for a new Marijuana Product Manufacturing Facility License and additional information for the following applicant:

License #: **20832**  
License Type: **Marijuana Product Manufacturing Facility**  
D.B.A.: Good Titrations  
Licensee/Applicant: FSE, Inc.  
Physical Location: 506 Merhar Avenue, Fairbanks, Alaska

Pursuant to FGC Sec. 14-214 and 3 AAC 306.060, the Council must determine whether to protest the marijuana license application after holding a public hearing.

A notice of the date, time, and place of the public hearing has been mailed to all property owners within 1,000 feet of the proposed cultivation facility, and notice of the public hearing will be advertised in the Fairbanks Daily News Miner on Friday, April 10, 2020.

The the Police Department has included a one-year call report for the location, but Chief Reeder is not recommending protest. The Building and Fire Departments are recommending protest until construction is complete and a Certificate of Occupancy is issued. There are no other departmental objections to the issuance of the license.



**CITY OF FAIRBANKS PUBLIC SAFETY**

**Good Titrations 506 Merhar Ave**

04/01/2019 - 03/30/2020

| <b>Report #</b> | <b>Call Time</b> | <b>Nature</b>    | <b>Location</b> | <b>Prime Unit</b> | <b>Disp.</b> | <b>Close Time</b>   |
|-----------------|------------------|------------------|-----------------|-------------------|--------------|---------------------|
|                 | 01/18/2020 15:07 | URGENT WELFARE   | 506 MERHAR AVE  | O50               | NRP          | 01/18/2020 15:37:46 |
|                 | 01/13/2020 14:35 | TRESPASS/UNWANTE | 506 MERHAR AVE  | O13               | NRP          | 01/13/2020 15:24:14 |
|                 | 01/03/2020 15:33 | SUSP             | 506 MERHAR AVE  | S6                | NRP          | 01/03/2020 15:47:38 |
|                 | 06/08/2019 17:56 | ALARM BURGLARY - | 506 MERHAR AVE  | S3                | FAB          | 06/08/2019 18:13:43 |
|                 | 05/22/2019 11:11 | ALARM BURGLARY - | 506 MERHAR AVE  | O3                | FAB          | 05/22/2019 11:40:46 |

Total Number of Events Listed: **5**



# City of Fairbanks

Office of the City Clerk

800 Cushman Street

Fairbanks, AK 99701

(907)459-6715

Fax (907)459-6710

## ALCOHOL AND MARIJUANA CONTROL OFFICE MARIJUANA LICENSE RESPONSE FORM

- TO:  FINANCE DEPARTMENT  
 BUILDING DEPARTMENT  
 FIRE DEPARTMENT  
 POLICE DEPARTMENT

DATE: 03/03/2020

FROM: CITY CLERK'S OFFICE

RE: MARIJUANA LICENSE ACTION – NEW PRODUCT MANUFACTURING APPLICATION

DATE NOTICE RECEIVED AT CLERKS OFFICE: 03/03/2020 (60 DAY DUE DATE 05/01/2020)

DATE RESPONSE DUE: 04/07/2020 for City Council Meeting of 04/13/2020

License #: 20832  
 License Type: Marijuana Product Manufacturing Facility  
 D.B.A.: Good Titrations  
 Licensee/Applicant: FSE, Inc.  
 Physical Location: 506 Merhar Avenue, Fairbanks, Alaska

| Corp/LLC Agent:            | Mailing Address                        | Phone        | Date and State of Ltd/Partner/Corp | Good Standing? |
|----------------------------|--|--------------|------------------------------------|----------------|
| FSE, Inc.<br>Frank Berardi | 801 Pelican Way<br>Fairbanks, AK 99709 | 907-231-2943 | 01/14/2015 – AK                    | Yes            |

Please note: Members/Officers/Directors listed below are the principal members. There may be additional shareholders. All members who hold at least 10% shares are listed.

| Member/Officer/Affiliate: | Mailing Address                                    | Phone        | Title/Shares (%)  |
|---------------------------|--|--------------|---|
| Brandon Emmett            | 1299 Lowbush Lane<br>Fairbanks, AK 99709           | 907-328-8529 | Vice President/Director/Secretary/<br>Shareholder – 25% |
| Frank Berardi             | 801 Pelican Way<br>Fairbanks, AK 99709             | 907-231-2943 | President/Director/Shareholder – 25%                    |
| Shaun Tacke               | 1770 Donald Avenue, Suite B<br>Fairbanks, AK 99701 | 907-978-7647 | Treasurer/Director/Shareholder – 25%                    |

### ADDITIONAL COMMENTS:

NO PROTEST:  
COMMENTS

PROTEST REASONS: UNTIL CERTIFICATE OF OCCUPANCY IS ISSUED

DEPARTMENT SIGNEE:

*[Handwritten Signature]*  
(Signature)

CLEMENS M. CLOOTEN  
(Printed Name)

NOTE: THIS COMPLETED FORM MUST BE RETURNED TO THE CITY CLERK'S OFFICE BY THE DATE INDICATED ABOVE. YOU MAY E-MAIL OR FAX (459-6710) THE FORM. IF YOU HAVE ANY QUESTIONS CALL OUR OFFICE AT 459-6774. THANK YOU.



# City of Fairbanks

Office of the City Clerk

800 Cushman Street

Fairbanks, AK 99701

(907)459-6715  
Fax (907)459-6710

## ALCOHOL AND MARIJUANA CONTROL OFFICE MARIJUANA LICENSE RESPONSE FORM

- TO:  FINANCE DEPARTMENT  
 BUILDING DEPARTMENT  
 FIRE DEPARTMENT  
 POLICE DEPARTMENT

DATE: 03/03/2020

FROM: CITY CLERK'S OFFICE

RE: MARIJUANA LICENSE ACTION – NEW PRODUCT MANUFACTURING APPLICATION

DATE NOTICE RECEIVED AT CLERKS OFFICE: 03/03/2020 (60 DAY DUE DATE 05/01/2020)

DATE RESPONSE DUE: **04/07/2020** for City Council Meeting of 04/13/2020

License #: 20832  
License Type: Marijuana Product Manufacturing Facility  
D.B.A.: Good Titrations  
Licensee/Applicant: FSE, Inc.  
Physical Location: 506 Merhar Avenue, Fairbanks, Alaska

| Corp/LLC Agent:            | Mailing Address                        | Phone        | Date and State of Ltd/Partner/Corp | Good Standing? |
|----------------------------|--|--------------|------------------------------------|----------------|
| FSE, Inc.<br>Frank Berardi | 801 Pelican Way<br>Fairbanks, AK 99709 | 907-231-2943 | 01/14/2015 – AK                    | Yes            |

Please note: Members/Officers/Directors listed below are the principal members. There may be additional shareholders. All members who hold at least 10% shares are listed.

| Member/Officer/Affiliate: | Mailing Address                                    | Phone        | Title/Shares (%)  |
|---------------------------|--|--------------|---|
| Brandon Emmett            | 1299 Lowbush Lane<br>Fairbanks, AK 99709           | 907-328-8529 | Vice President/Director/Secretary/<br>Shareholder – 25% |
| Frank Berardi             | 801 Pelican Way<br>Fairbanks, AK 99709             | 907-231-2943 | President/Director/Shareholder – 25%                    |
| Shaun Tacke               | 1770 Donald Avenue, Suite B<br>Fairbanks, AK 99701 | 907-978-7647 | Treasurer/Director/Shareholder – 25%                    |

### ADDITIONAL COMMENTS:

- NO PROTEST:  
COMMENTS
- PROTEST  
REASONS: Construction and Certificate of Occupancy incomplete

DEPARTMENT SIGNEE: James N. Styers / James N. Styers  
(Signature) (Printed Name)

NOTE: THIS COMPLETED FORM MUST BE RETURNED TO THE CITY CLERK'S OFFICE  
BY THE DATE INDICATED ABOVE. YOU MAY E-MAIL OR FAX (459-6710) THE FORM.  
IF YOU HAVE ANY QUESTIONS CALL OUR OFFICE AT 459-6774. THANK YOU.

# Alcohol & Marijuana Control Office

**License Number:** 20832

**License Status:** New

**License Type:** Marijuana Product Manufacturing Facility

**Doing Business As:** GOOD TITRATIONS

**Business License Number:** 1040494

**Designated Licensee:** Shaun Tacke

**Email Address:** shaun@goodtitrations.com

**Local Government:** Fairbanks (City of)

**Community Council:**

**Latitude, Longitude:** 64.858000, -147.694000

**Physical Address:** 506 Merhar Ave  
Fairbanks, AK 99701  
UNITED STATES

### Licensee #1

**Type:** Entity

**Alaska Entity Number:** 10026238

**Alaska Entity Name:** FSE, Inc.

**Phone Number:** 907-978-7647

**Email Address:** shaun@goodtitrations.com

**Mailing Address:** 1770 Donald Ave  
Suite B  
Fairbanks, AK 99701  
UNITED STATES

### Entity Official #1

**Type:** Individual

**Name:** Jeffrey Weltzin

**Phone Number:** 907-590-1305

**Email Address:** jeffreyyweltzin@gmail.com

**Mailing Address:** 3844 Ullrbahn Rd  
Fairbanks, AK 99709  
UNITED STATES

### Entity Official #2

**Type:** Individual

**Name:** Naomi Johnson

**Phone Number:** 907-388-0446

**Email Address:** naomiraven.nj@gmail.com

**Mailing Address:** 100 10th Ave  
Apt 2B6  
Fairbanks, AK 99701  
UNITED STATES

### Entity Official #3

**Type:** Individual

**Name:** Judy Bath

**Phone Number:** 907-488-9451

**Email Address:** jkbath@hotmail.com

**Mailing Address:** 545 Freeman Rd  
North Pole, AK 99705  
UNITED STATES

### Entity Official #4

**Type:** Individual

**Name:** Seth Hawkins

**Phone Number:** 907-347-4372

**Email Address:** sethhawkins@hotmail.com

**Mailing Address:** PO Box 70018  
Fairbanks, AK 99707  
UNITED STATES

### Entity Official #5

**Type:** Individual

**Name:** Martin Tacke

**Phone Number:** 907-460-2472

**Email Address:** marty.tacke@gmail.com

**Mailing Address:** 1770 Donald Ave  
Fairbanks, AK 99701  
UNITED STATES



**Entity Official #6**

**Type:** Individual

**Name:** Craig O'Donoghue

[REDACTED]

[REDACTED]

**Phone Number:** 907-378-3645

**Email Address:** fairbanksdentist@gmail.com

**Mailing Address:** 4740 Villanova Dr  
#A  
Fairbanks, AK 99709  
UNITED STATES

**Entity Official #7**

**Type:** Individual

**Name:** Shaun Tacke

[REDACTED]

[REDACTED]

**Phone Number:** 907-978-7647

**Email Address:** shaun@goodtitrations.com

**Mailing Address:** PO Box 82011  
Fairbanks, AK 99708  
UNITED STATES

**Entity Official #8**

**Type:** Individual

**Name:** Curtis Franklin

[REDACTED]

[REDACTED]

**Phone Number:** 907-322-7945

**Email Address:** curtfran68@gmail.com

**Mailing Address:** 3760 Mitchell Ave  
Fairbanks, AK 99709  
UNITED STATES

**Entity Official #9**

**Type:** Individual

**Name:** Joshua Spence

[REDACTED]

[REDACTED]

**Phone Number:** 907-488-1823

**Email Address:** spencej@live.com

**Mailing Address:** 2296 Outside Blvd  
North Pole, AK 99705  
UNITED STATES

**Entity Official #10**

**Type:** Individual

**Name:** Frank Berardi

[REDACTED]

[REDACTED]

**Phone Number:** 907-231-2943

**Email Address:** frankberardi185@gmail.com

**Mailing Address:** 801 Pelican Way  
Fairbanks, AK 99709  
UNITED STATES

**Entity Official #11**

**Type:** Individual

**Name:** Brandon Emmett

[REDACTED]

[REDACTED]

**Phone Number:** 907-328-8529

**Email Address:** frankbrank185@gmail.com

**Mailing Address:** 801 Pelican Way  
Fairbanks, AK 99709  
UNITED STATES

**Entity Official #12**

**Type:** Individual

**Name:** Lynn Crane

[REDACTED]

[REDACTED]

**Phone Number:** 907-581-3248

**Email Address:** unakwoman@yahoo.com

**Mailing Address:** PO Box 626  
Unalaska, AK 99685  
UNITED STATES

**Entity Official #13**

**Type:** Entity

**Alaska Entity Number:** 10039028

**Alaska Entity Name:** U.N.ME, LLC

**Phone Number:** 662-694-9025

**Email Address:** mbroach1@gmail.com

**Mailing Address:** 607 Old Steese Hwy  
Ste B209  
Fairbanks, AK 99701  
UNITED STATES

**Entity Official #14**

**Type:** Individual

**Name:** Joanne Ellsworth

[REDACTED]

[REDACTED]

**Phone Number:** 907-451-9401

**Email Address:** dickells74@gmail.com

**Mailing Address:** 2581 Goldstream Rd  
Fairbanks, AK 99709  
UNITED STATES

**Entity Official #15**

**Type:** Individual

**Name:** Billie Jo Gehring

[REDACTED]

[REDACTED]

**Phone Number:** 907-359-2246

**Email Address:** billiejogehring@gmail.com

**Mailing Address:** PO Box 226  
Unalaska, AK 99685  
UNITED STATES

**Entity Official #16**

**Type:** Individual

**Name:** Dawson Carroll

[REDACTED]

[REDACTED]

**Phone Number:** 907-687-6097

**Email Address:** dawsoncarroll74@yahoo.com

**Mailing Address:** 163 Carlyle Way  
Fairbanks, AK 99709  
UNITED STATES

**Entity Official #17**

**Type:** Individual

**Name:** Melissa Cervantes

[REDACTED]

[REDACTED]

**Phone Number:** 662-694-9025

**Email Address:** mbroach1@gmail.com

**Mailing Address:** 607 Old Steese Hwy  
Ste B209  
Fairbanks, AK 99701  
UNITED STATES

**Entity Official #18**

**Type:** Individual

**Name:** Michael Cervantes

[REDACTED]

[REDACTED]

**Phone Number:** 907-460-2704

**Email Address:** michael@goodtitrations.com

**Mailing Address:** 607 Old Steese Hwy  
Ste B209  
Fairbanks, AK 99701  
UNITED STATES

**Note:** No affiliates entered for this license.



**Alaska Marijuana Control Board**  
**Operating Plan Supplemental**  
**Form MJ-05: Marijuana Product Manufacturing Facility**

**What is this form?**

This operating plan supplemental form is required for all applicants seeking a marijuana product manufacturing facility license and must accompany **Form MJ-01: Marijuana Establishment Operating Plan**, per 3 AAC 306.020(b)(11). Applicants should review **Chapter 306: Article 5** of the **Alaska Administrative Code**. This form will be used to document how an applicant intends to meet the requirements of the statutes and regulations.

If your business has a formal operating plan, you may include a copy of that operating plan with your application, but all fields of this form must still be completed per 3 AAC 306.020 and 3 AAC 306.520(3).

**What additional information is required for cultivation facilities?**

Applicants must identify how the proposed establishment will comply with applicable regulations regarding the following:

- Equipment, compounds, and processes to be used
- Waste disposal
- Testing procedure and protocols
- Proposed marijuana concentrates and marijuana products
- Proposed product packaging and sample labels
- Prohibitions

**This form must be completed and submitted to AMCO's main office before any new or transfer application for a marijuana product manufacturing facility or marijuana concentrate manufacturing facility license will be considered complete.**

**Section 1 – Establishment Information**

Enter information for the business seeking to be licensed, as identified on the license application.

|                           |  |                      |        |             |       |
|---------------------------|--|----------------------|--------|-------------|-------|
| <b>Licensee:</b>          | FSE, Inc.                                | <b>MJ License #:</b> | 20832  |             |       |
| <b>License Type:</b>      | Marijuana Product Manufacturing Facility |                      |        |             |       |
| <b>Doing Business As:</b> | GOOD TITRATIONS                          |                      |        |             |       |
| <b>Premises Address:</b>  | 506 Merhar Avenue                        |                      |        |             |       |
| <b>City:</b>              | Fairbanks                                | <b>State:</b>        | Alaska | <b>ZIP:</b> | 99701 |



**Section 2 – Overview of Operations**

2.1. Provide an overview of your proposed facility's operations. Include information regarding the intake, flow, and transfer of marijuana, marijuana concentrate, and marijuana product at and from your premises:

All Shipments of marijuana and marijuana product that arrives at the facility will be first inspected by a licensee or designated employee before being accepted and entered as inventory. The shipment contents will be reconciled with the transport manifest, shipment labels and packaging labels to ensure consistency. All product will be weighed by Good Titrations and reconciled with the weight listed on the manifest and labels. Any shipments with discrepancies will be rejected. Shipments that pass initial inspection will be accepted into the facility, immediately entered into METRC and added to the inventory log. All marijuana and marijuana products will be tracked in METRC from intake into the facility, to its use in a manufactured product or disposal, to its transfer to another licensed facility. At the end of each business day, the Good Titrations management team will reconcile each transfer to or from another licensed facility with METRC and the inventory on hand to ensure consistency and to resolve discrepancies immediately. A random sample of each product manufactured at the facility will be sent to a licensed testing lab before being transferred to another licensed facility and the remainder of the production lot will be segregated from all other product until the testing results are received. Once passing testing results are received from the testing lab, marijuana products will be packaged and labeled in compliance with AMCO Regulations. The packaged products will then be transported by an agent of Good Titrations who holds a valid marijuana handler permit or by a third-party transport company with valid marijuana handler permits. All transfers will be entered into METRC and a trip manifest will be set with each shipment as well as stored on site as a business record.

**Section 3 – Equipment and Compounds to be Used**

Review the requirements under 3 AAC 306.555.

3.1. Describe the equipment and solvents, gases, chemicals, and other compounds the marijuana product manufacturing facility will use to create marijuana concentrates:

Good Titrations will employ the following methods/techniques and equipment to create and process marijuana concentrate and other marijuana by-products and extractions: Closed loop extractor that uses Butane, N-Butane, ethanol, and Iso-Butane for extraction. Also used is a recovery pump, filter drier, Erlenmeyer flasks and a magnetic stirring plate, vacuum assisted Whatman filter system and filter vacuum flask, tubing machine and rotary evaporator. The facility may also use methods of extraction that do not require solvents such as keif sifting, cold water/dry ice methods, and heat-press for rosin extracting.





**Section 4 – Waste Disposal**

Review the requirements under 3 AAC 306.740.

You must be able to certify the statement below. Read the following and then sign your initials in the box to the right: Initials

4.1. The marijuana product manufacturing facility shall give the board at least three days written notice required under 3 AAC 306.740(c) before making marijuana waste unusable and disposing of it.

ST

4.2. Describe how you will store, manage, and dispose of any solid or liquid marijuana waste, including expired or outdated marijuana or marijuana product, in compliance with any applicable laws. Include details about the material(s) you will mix with ground marijuana waste and the processes that you will use to make the marijuana waste unusable for any purpose for which it was grown or produced:

Good Titrations anticipates the following marijuana plant and product waste at the manufacturing facility; (1) contaminated or infected marijuana or marijuana products (2) marijuana or marijuana products deemed by the licensee or a manager as unfit for sale or consumption for any reason (3) marijuana product that fails testing (4) marijuana plant waste created during the extraction process (5) marijuana or marijuana product that becomes expired (6) other marijuana or marijuana product waste as determined by the MCB or director. Once marijuana or marijuana product is deemed as waste, it will be separated from all other marijuana and marijuana products and securely stored in locked bins on the licensed premises and an email notification will be sent to AMCO Enforcement at least 3 days prior to rendering the waste unusable as well as recording the waste in METRC. All solid marijuana plant waste (plant matter waste from the extraction process such as plant matter that is pressed/squeezed to extract oil) and marijuana product waste will be ground in a grinder and then mixed with other solid compost-able or non-compostable waste such as, paper waste, plastic waste, cardboard waste, and soil until the mixture is no more than 50% marijuana waste. Liquid marijuana waste such as concentrates will be mixed with at least equal parts of non-marijuana waste and then stored away from all other marijuana and marijuana products in locked containers on the premises, inside the facility in the locked waste container then transferred to the outdoors locked container once rendered unusable. The waste will then be picked up by the local waste truck and taken to the landfill. The logged information will be available to AMCO at any time upon request, and securely stored.



**Section 5 – Testing Procedure and Protocols**

Review the requirements under 3 AAC 306.520 and 3 AAC 306.550.

You must be able to certify the statement below. Read the following and then sign your initials in the box to the right: Initials

5.1. I will ensure that any individual responsible for collecting random samples for required laboratory testing under 3 AAC 306.550 will prepare the necessary accompanying signed statement, provide the signed statement to the marijuana testing facility, and maintain a copy as a business record under 3 AAC 306.755.

ST

Answer "Yes" or "No" to the following question:

Yes No

5.2. Will the marijuana product manufacturing facility be performing in-house testing (as defined under 3 AAC 306.990(b)(20)?

If "Yes" to 5.2, you must be able to certify the statement below. Read the following and then sign your initials in the box: Initials

5.3. The area where in-house testing will occur is clearly identified on the Form MJ-02: Premises Diagram that is submitted with this application.

5.4. Describe the testing procedures and protocols the marijuana product manufacturing facility will follow:

A designated Good Titrations employee will be responsible for collecting a random sample from each production lot to be sent to a licensed testing facility. The designated employee will sign a statement certifying that the sample was randomly selected. A copy of the signed statement will accompany the sample to the testing facility and another copy will be filed on-site as a business record. The sample will be transported to the testing facility by a Good Titrations agent who holds a valid marijuana handler permit or by a third-party transport company who has valid marijuana handler permits. The remainder of the production lot will be segregated from all other marijuana and marijuana products in secure containers until the testing results are received. During the quarantine period, all product will be securely stored on-site and then Good Titrations will ensure the products are kept cool and dry to prevent contamination or loss of efficacy. A copy of the testing facility results will be stored in the office on-site as an official business record and will be made available to AMCO upon request.



Section 8 – Prohibitions

Review the requirements under 3 AAC 306.510.

8.1. I certify that the marijuana product manufacturing facility will not:

Initials

a. sell, deliver, distribute, or transfer any marijuana, marijuana concentrate, or marijuana product directly to a consumer, with or without compensation;

ST

b. allow any person, including a licensee, employee, or agent, to consume marijuana, marijuana concentrate, or marijuana product on the licensed premises; or

ST

c. manufacture or sell any product that is an adulterated food or drink, closely resembles a familiar food or drink item including candy, or is packaged to look like candy, or in bright colors or with cartoon characters or other pictures or images that would appeal to children.

ST

I declare under penalty of unsworn falsification that this form, including all accompanying schedules and statements, is true, correct, and complete.

[Handwritten signature of Shawn Tacke]

Signature of licensee

Shawn Tacke  
Printed name of licensee

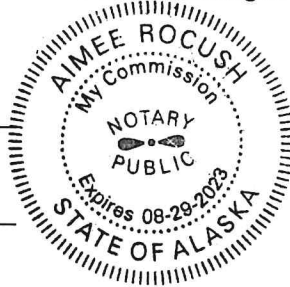

[Handwritten signature of Aimee Rocush]

Notary Public in and for the State of Alaska

My commission expires: 8/29/2023

Subscribed and sworn to before me this 20 day of December, 2019.



(Additional Space as Needed):





**Section 6 – Proposed Marijuana Concentrates and Marijuana Products**

Review the requirements under 3 AAC 306.520, 3 AAC 306.525, and 3 AAC 306.560.

Attach a completed copy of this page for each proposed marijuana concentrate or marijuana product.

|   |                         |                                   |          |
|---|-------------------------|-----------------------------------|----------|
| <b>Product Name:</b>  | Good Vibes BBQ Cup      |                                   |          |
| <b>Product Type:</b> Choose one.                                | Other Marijuana Product |                                   |          |
| <b>Perishable:</b> Yes/No                                       | Yes                     | <b>Shelf Life:</b> If perishable. | 9 Months |
| <b>Intended Use:</b> Smokable/<br>edible/topical/wholesale/etc. | Edible                  |                                   |          |

|  |   |
|--|---|
| <b>Product Description:</b><br>Details must include the color, shape, and texture. | Good Vibes BBQ will be brown in color. Good Vibes BBQ produced in a liquid sauce form with a smooth texture. Good Vibes BBQ sauce is used as a condiment. Available in 1mg, 2.5mg and 5mg of THC per singular pc cup. |
|--|---|

|                     |   |
|---------------------|---|
| <b>Ingredients:</b> | Cherry tomatoes, chopped yellow onions, garlic cloves – minced, salted butter, light brown sugar, white vinegar, yellow mustard powder, Worcestershire, kosher salt and black pepper and canna-concentrate (an approved Good Titrations product that will be transferred from the existing manufacturing facility to produce this product). |
|---------------------|---|

|  |  |
|--|--|
| <b>Standard Production Procedure and Detailed Manufacturing Process:</b> | Take tomatoes, and cook, until skins begin to split and char. Add onions and garlic, and cook. Add butter to pan, and cook until melted. Add brown sugar; stir until combined. Cook, without stirring, until edges start to caramelize. Stir in vinegar, mustard, Worcestershire, salt, and pepper; reduce heat to medium-low, and cook until tomatoes completely break down and mixture is slightly thickened. Remove from heat, and carefully transfer to a blender. Remove center piece of blender lid; process on high until almost smooth. Cool completely, whisk in canna-concentrate and dispense the batch into final packaging. |
|--|--|

|  |   |
|--|---|
| <b>Depiction:</b><br>Provide a photograph, drawing, or graphic representation of the expected appearance of the final product. | <p><b>**Graphic Representation**</b></p>  |
|--|---|



Section 7 – Proposed Product Packaging and Sample Labels

Review the requirements under 3 AAC 306.520, 3 AAC 306.565, and 3 AAC 306.570.

Attach a completed copy of this page for each proposed marijuana concentrate or marijuana product.

|                      |                    |
|----------------------|--------------------|
| <b>Product Name:</b> | Good Vibes BBQ Cup |
| <b>Product Type:</b> | Edible             |

|  |  |
|--|--|
| <p><b>Packaging Description:</b><br/>Details must include the color(s), size, packaging materials used, total amount of THC, individual serving sizes (if multiple), and other specifics showing compliance with 3 AAC 306.565. Please include photos, drawings, or graphic representations.</p> | <p>The pc (portion control) cup is a small 2oz container, made from paper, plastic or another type of serving material, often used to contain individual serving quantities of foods or consumer goods. The pc cup will be used for in-house usage only and any product left after customer leaves will be discarded by employee's. The pc cup will come in three sizes. SIZE ONE (1); 1 individual pc cup totaling 1mg of THC. SIZE TWO (2); 1 individual pc cup totaling 2.5mg of THC. SIZE THREE (3); 1 individual pc cup totaling 5mg of THC.</p> <div style="text-align: center;">  </div> |
|--|--|

|  |   |
|--|---|
| <p><b>Sample Labels:</b><br/>Provide sample labels showing how the labeling requirements set forth in 3 AAC 306.570 will be met.</p> | <p><b>Produced By:</b> Good Titrations<br/> <b>License Number:</b> 20832<br/> <b>Product Name:</b> Good Vibes BBQ PC    <b>Strain:</b><br/> <b>Batch/Lot Number:</b>    <b>Gross Weight:</b>    <b>Net MJ Weight:</b>    <u>OZ</u> ( g)<br/> <b>Best By Date:</b>    <b>Packaging Date:</b><br/> <b>Tested By:</b>    <b>License Number:</b><br/> <b>Total THC:</b>    <b>THCA:</b>    <b>CBD:</b>    <b>CBDA:</b>    <b>CBN:</b><br/> <b>Microbial Test:</b>    <b>Pesticides:</b>    <b>Herbicides:</b><br/> <b>Fungicides:</b><br/> <b>Residual Solvent Test:</b>    <b>Contaminants Test Result:</b><br/> <b>Retailer:</b>    <b>License Number:</b><br/> <b>Alaska Safety Warning:</b> Marijuana has intoxicating effects and may be habit forming and addictive. Marijuana impairs concentration, coordination and judgment. Do not operate a vehicle or machinery under its influence. There are health risks associated with consumption of marijuana. For use only by adults twenty-one and older. Keep out of the reach of children. Marijuana should not be used by women who are pregnant or breast feeding.<br/> <b>*Keep Refrigerated*</b>    Label will include nutritional information &amp; full list of ingredients</p> |
|--|---|



Section 6 – Proposed Marijuana Concentrates and Marijuana Products

Review the requirements under 3 AAC 306.520, 3 AAC 306.525, and 3 AAC 306.560.

Attach a completed copy of this page for each proposed marijuana concentrate or marijuana product.

|  |  |                                   |          |
|--|--|-----------------------------------|----------|
| <b>Product Name:</b>   | Good Vibes BBQ Packet  |                                   |          |
| <b>Product Type:</b> Choose one.   | Other Marijuana Product  |                                   |          |
| <b>Perishable:</b> Yes/No  | Yes  | <b>Shelf Life:</b> If perishable. | 9 Months |
| <b>Intended Use:</b> Smokable/<br>edible/topical/wholesale/etc.  | Edible   |                                   |          |
| <b>Product Description:</b><br>Details must include the color, shape, and texture.   | Good Vibes BBQ will be brown in color. Good Vibes BBQ produced in a liquid sauce form with a smooth texture. Good Vibes BBQ is a sauce used as a condiment. Available in 1mg, 2.5mg and 5mg of THC per singular packet.  |                                   |          |
| <b>Ingredients:</b>  | Cherry tomatoes, chopped yellow onions, garlic cloves – minced, salted butter, light brown sugar, white vinegar, yellow mustard powder, Worcestershire, kosher salt and black pepper and canna-concentrate (an approved Good Titrations product that will be transferred from the existing manufacturing facility to produce this product).  |                                   |          |
| <b>Standard Production Procedure and Detailed Manufacturing Process:</b>   | Take tomatoes, and cook, until skins begin to split and char. Add onions and garlic, and cook. Add butter to pan, and cook until melted. Add brown sugar; stir until combined. Cook, without stirring, until edges start to caramelize. Stir in vinegar, mustard, Worcestershire, salt, and pepper; reduce heat to medium-low, and cook until tomatoes completely break down and mixture is slightly thickened. Remove from heat, and carefully transfer to a blender. Remove center piece of blender lid; process on high until almost smooth. Cool completely, whisk in canna-concentrate and dispense the batch into final packaging. |                                   |          |
| <b>Depiction:</b><br>Provide a photograph, drawing, or graphic representation of the expected appearance of the final product. | <p>**Graphic Representation**</p>    |                                   |          |





Section 7 – Proposed Product Packaging and Sample Labels

Review the requirements under 3 AAC 306.520, 3 AAC 306.565, and 3 AAC 306.570.

Attach a completed copy of this page for each proposed marijuana concentrate or marijuana product.

|                      |                |
|----------------------|----------------|
| <b>Product Name:</b> | Good Vibes BBQ |
| <b>Product Type:</b> | Edible         |

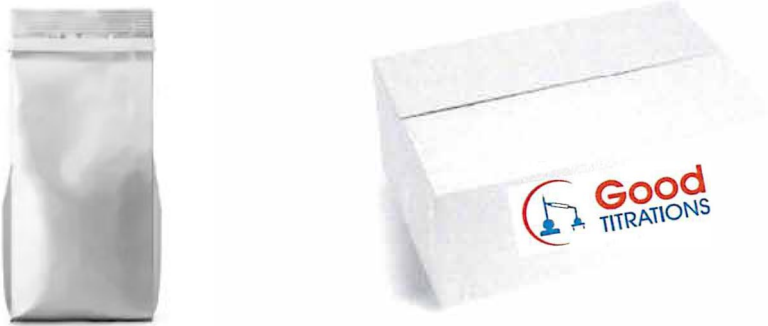
|  |  |
|--|--|
| <p><b>Packaging Description:</b><br/>Details must include the color(s), size, packaging materials used, total amount of THC, individual serving sizes (if multiple), and other specifics showing compliance with 3 AAC 306.565. Please include photos, drawings, or graphic representations.</p> | <p>The packet is a small bag or pouch, made from paper, foil, plastic film or another type of packing material, often used to contain single-use quantities of foods or consumer goods. The packet will come in six sizes. SIZE ONE (1); 50 packets in a single package, each packet would be 1mg of THC totaling 50mg of THC per package. SIZE TWO (2); 20 packets in a single package, each packet would be 2.5mg of THC totaling 50mg of THC per package. SIZE THREE (3); 10 packets in a single package, each packet would be 5mg of THC totaling 50mg of THC per package. SIZE FOUR (4); 1 individual packet totaling 1mg of THC. SIZE FIVE (5); 1 individual packet totaling 2.5mg of THC. SIZE SIX (6); 1 individual packet totaling 5mg of THC.</p> <div style="text-align: center;">  </div> |
|--|--|

|  |  |
|--|--|
| <p><b>Sample Labels:</b><br/>Provide sample labels showing how the labeling requirements set forth in 3 AAC 306.570 will be met.</p> | <p><b>Produced By:</b> Good Titrations<br/> <b>License Number:</b> 20832<br/> <b>Product Name:</b> Good Vibes BBQ      <b>Strain:</b><br/> <b>Batch/Lot Number:</b>      <b>Gross Weight:</b>      <b>Net MJ Weight:</b>      <u>OZ</u> ( g)<br/> <b>Best By Date:</b>      <b>Packaging Date:</b><br/> <b>Tested By:</b>      <b>License Number:</b><br/> <b>Total THC:</b>      <b>THCA:</b>      <b>CBD:</b>      <b>CBDA:</b>      <b>CBN:</b><br/> <b>Microbial Test:</b>      <b>Pesticides:</b>      <b>Herbicides:</b><br/> <b>Fungicides:</b><br/> <b>Residual Solvent Test:</b>      <b>Contaminants Test Result:</b><br/> <b>Retailer:</b>      <b>License Number:</b><br/> <b>Alaska Safety Warning:</b> Marijuana has intoxicating effects and may be habit forming and addictive. Marijuana impairs concentration, coordination and judgment. Do not operate a vehicle or machinery under its influence. There are health risks associated with consumption of marijuana. For use only by adults twenty-one and older. Keep out of the reach of children. Marijuana should not be used by women who are pregnant or breast feeding.<br/> <b>*Keep Refrigerated*</b>      Label will include nutritional information &amp; full list of ingredients</p> |
|--|--|





**Section 6 – Proposed Marijuana Concentrates and Marijuana Products**

Review the requirements under 3 AAC 306.520, 3 AAC 306.525, and 3 AAC 306.560.

Attach a completed copy of this page for each proposed marijuana concentrate or marijuana product.

|   |                                |                                   |          |
|---|--------------------------------|-----------------------------------|----------|
| <b>Product Name:</b>  | Good Vibes Cream Cheese Packet |                                   |          |
| <b>Product Type:</b> Choose one.                                | Other Marijuana Product        |                                   |          |
| <b>Perishable:</b> Yes/No                                       | Yes                            | <b>Shelf Life:</b> If perishable. | 9 Months |
| <b>Intended Use:</b> Smokable/<br>edible/topical/wholesale/etc. | Edible                         |                                   |          |

|  |  |
|--|--|
| <b>Product Description:</b><br>Details must include the color, shape, and texture. | Good Vibes Cream cheese will be white in color. Good Vibes Cream cheese is produced in a creamy liquid form with a smooth texture. Good Vibes Cream cheese is a cream used as a condiment. Available in 1mg, 2.5mg and 5mg of THC per singular packet. |
|--|--|

|                     |  |
|---------------------|--|
| <b>Ingredients:</b> | Cream cheese, milk and canna-concentrate (an approved product transferred from Good Titrations existing manufacturing facility to produce this product). |
|---------------------|--|

|  |   |
|--|---|
| <b>Standard Production Procedure and Detailed Manufacturing Process:</b> | Using a mixer with the paddle attachment, beat cream cheese with powdered sugar until all lumps are gone. Switch the paddle attachment with the whisk attachment & the whip topping. Whip until light, airy and stiff peaks form. Cool completely, fold-in canna-concentrate and dispense the batch into final packaging. |
|--|---|

|  |   |
|--|---|
| <b>Depiction:</b><br>Provide a photograph, drawing, or graphic representation of the expected appearance of the final product. | <p><b>**Graphic Representation**</b></p>  |
|--|---|



**Section 7 – Proposed Product Packaging and Sample Labels**

Review the requirements under 3 AAC 306.520, 3 AAC 306.565, and 3 AAC 306.570.

Attach a completed copy of this page for each proposed marijuana concentrate or marijuana product.

|                      |                                |
|----------------------|--------------------------------|
| <b>Product Name:</b> | Good Vibes Cream Cheese Packet |
| <b>Product Type:</b> | Edible                         |

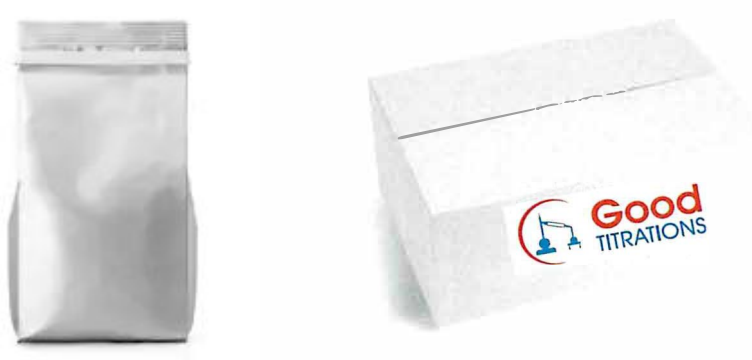
|  |  |
|--|--|
| <p><b>Packaging Description:</b><br/>Details must include the color(s), size, packaging materials used, total amount of THC, individual serving sizes (if multiple), and other specifics showing compliance with 3 AAC 306.565. Please include photos, drawings, or graphic representations.</p> | <p>The packet is a small bag or pouch, made from paper, foil, plastic film or another type of packing material, often used to contain single-use quantities of foods or consumer goods. The packet will come in six sizes. SIZE ONE (1); 50 packets in a single package, each packet would be 1mg of THC totaling 50mg of THC per package. SIZE TWO (2); 20 packets in a single package, each packet would be 2.5mg of THC totaling 50mg of THC per package. SIZE THREE (3); 10 packets in a single package, each packet would be 5mg of THC totaling 50mg of THC per package. SIZE FOUR (4); 1 individual packet totaling 1mg of THC. SIZE FIVE (5); 1 individual packet totaling 2.5mg of THC. SIZE SIX (6); 1 individual packet totaling 5mg of THC.</p> <div style="text-align: center;">  </div> |
|--|--|

|  |  |
|--|--|
| <p><b>Sample Labels:</b><br/>Provide sample labels showing how the labeling requirements set forth in 3 AAC 306.570 will be met.</p> | <p><b>Produced By:</b> Good Titrations<br/> <b>License Number:</b> 20832<br/> <b>Product Name:</b> Good Vibes Cream Cheese    <b>Strain:</b><br/> <b>Batch/Lot Number:</b>    <b>Gross Weight:</b>    <b>Net MJ Weight:</b>    <u>OZ(</u> g)<br/> <b>Best By Date:</b>    <b>Packaging Date:</b><br/> <b>Tested By:</b>    <b>License Number:</b><br/> <b>Total THC:</b>    <b>THCA:</b>    <b>CBD:</b>    <b>CBDA:</b>    <b>CBN:</b><br/> <b>Microbial Test:</b>    <b>Pesticides:</b>    <b>Herbicides:</b><br/> <b>Fungicides:</b><br/> <b>Residual Solvent Test:</b>    <b>Contaminants Test Result:</b><br/> <b>Retailer:</b>    <b>License Number:</b><br/> <b>Alaska Safety Warning:</b> Marijuana has intoxicating effects and may be habit forming and addictive. Marijuana impairs concentration, coordination and judgment. Do not operate a vehicle or machinery under its influence. There are health risks associated with consumption of marijuana. For use only by adults twenty-one and older. Keep out of the reach of children. Marijuana should not be used by women who are pregnant or breast feeding.<br/> <b>*Keep Refrigerated*</b>    Label will include nutritional information &amp; full list of ingredients</p> |
|--|--|



**Section 6 – Proposed Marijuana Concentrates and Marijuana Products**

Review the requirements under 3 AAC 306.520, 3 AAC 306.525, and 3 AAC 306.560.

Attach a completed copy of this page for each proposed marijuana concentrate or marijuana product.

|   |                             |                                   |          |
|---|-----------------------------|-----------------------------------|----------|
| <b>Product Name:</b>  | Good Vibes Hot Sauce Packet |                                   |          |
| <b>Product Type:</b> Choose one.                                | Other Marijuana Product     |                                   |          |
| <b>Perishable:</b> Yes/No                                       | Yes                         | <b>Shelf Life:</b> If perishable. | 6 Months |
| <b>Intended Use:</b> Smokable/<br>edible/topical/wholesale/etc. | Edible                      |                                   |          |

|  |   |
|--|---|
| <b>Product Description:</b><br>Details must include the color, shape, and texture. | Good Vibes Hot Sauce will be reddish/orange in color. Good Vibes Hot Sauce is produced in a liquid form with a smooth texture. Good Vibes Hot Sauce is used as a condiment. Available in 1mg, 2.5mg and 5mg of THC per singular packet. |
|--|---|

|                     |  |
|---------------------|--|
| <b>Ingredients:</b> | Tabasco or Serrano chiles, minced garlic, onions, salt, vegetable oil, water, distilled white vinegar and canna-concentrate (an approved Good Titrations product that will be transferred from the existing manufacturing facility to produce this product). |
|---------------------|--|

|  |   |
|--|---|
| <b>Standard Production Procedure and Detailed Manufacturing Process:</b> | Combine the peppers, garlic, onions, salt and oil in a non-reactive saucepan over high heat. Sauté for 3 minutes then add the water and continue cooking, occasionally stirring for 20 minutes or until peppers are very soft (almost all the liquid has evaporated). Remove from heat and allow to steep until mixture come to room temperature. In a food processor, puree the mixture until smooth. Keeping the food processor going, add the vinegar slowly. Taste to determine desired flavor, add salt if necessary. Strain and refrigerate for 48 hours to build on flavor. After the 48 hours has finished, whisk in canna-concentrate and dispense the batch into final packaging. |
|--|---|

|  |  |
|--|--|
| <b>Depiction:</b><br>Provide a photograph, drawing, or graphic representation of the expected appearance of the final product. | <p><b>**Graphic Representation**</b></p>  |
|--|--|



**Section 7 – Proposed Product Packaging and Sample Labels**

Review the requirements under 3 AAC 306.520, 3 AAC 306.565, and 3 AAC 306.570.

Attach a completed copy of this page for each proposed marijuana concentrate or marijuana product.

|                      |                             |
|----------------------|-----------------------------|
| <b>Product Name:</b> | Good Vibes Hot Sauce Packet |
| <b>Product Type:</b> | Edible                      |

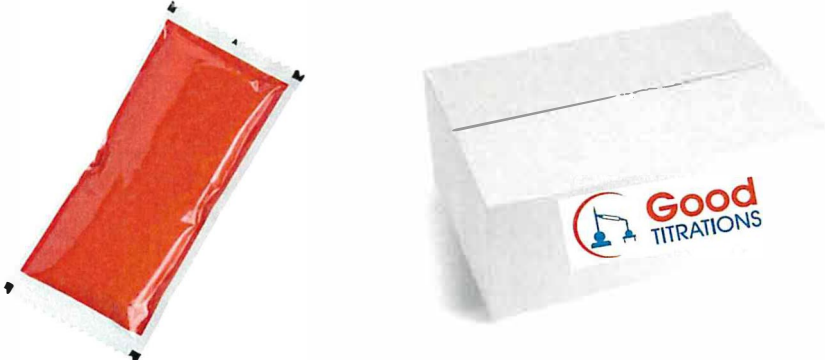
|  |  |
|--|--|
| <p><b>Packaging Description:</b><br/>Details must include the color(s), size, packaging materials used, total amount of THC, individual serving sizes (if multiple), and other specifics showing compliance with 3 AAC 306.565. Please include photos, drawings, or graphic representations.</p> | <p>The packet is a small bag or pouch, made from paper, foil, plastic film or another type of packing material, often used to contain single-use quantities of foods or consumer goods. The packet will come in six sizes. SIZE ONE (1); 50 packets in a single package, each packet would be 1mg of THC totaling 50mg of THC per package. SIZE TWO (2); 20 packets in a single package, each packet would be 2.5mg of THC totaling 50mg of THC per package. SIZE THREE (3); 10 packets in a single package, each packet would be 5mg of THC totaling 50mg of THC per package. SIZE FOUR (4); 1 individual packet totaling 1mg of THC. SIZE FIVE (5); 1 individual packet totaling 2.5mg of THC. SIZE SIX (6); 1 individual packet totaling 5mg of THC.</p> <div style="text-align: center;">  </div> |
|--|--|

|  |   |
|--|---|
| <p><b>Sample Labels:</b><br/>Provide sample labels showing how the labeling requirements set forth in 3 AAC 306.570 will be met.</p> | <p><b>Produced By:</b> Good Titrations<br/> <b>License Number:</b> 20832<br/> <b>Product Name:</b> Good Vibes Hot Sauce <b>Strain:</b><br/> <b>Batch/Lot Number:</b> <b>Gross Weight:</b> <b>Net MJ Weight:</b> <u>OZ</u> ( g)<br/> <b>Best By Date:</b> <b>Packaging Date:</b><br/> <b>Tested By:</b> <b>License Number:</b><br/> <b>Total THC:</b> <b>THCA:</b> <b>CBD:</b> <b>CBDA:</b> <b>CBN:</b><br/> <b>Microbial Test:</b> <b>Pesticides:</b> <b>Herbicides:</b><br/> <b>Fungicides:</b><br/> <b>Residual Solvent Test:</b> <b>Contaminants Test Result:</b><br/> <b>Retailer:</b> <b>License Number:</b><br/> <b>Alaska Safety Warning:</b> Marijuana has intoxicating effects and may be habit forming and addictive. Marijuana impairs concentration, coordination and judgment. Do not operate a vehicle or machinery under its influence. There are health risks associated with consumption of marijuana. For use only by adults twenty-one and older. Keep out of the reach of children. Marijuana should not be used by women who are pregnant or breast feeding.<br/> <b>*Keep Refrigerated*</b> Label will include nutritional information &amp; full list of ingredients</p> |
|--|---|





**Section 6 – Proposed Marijuana Concentrates and Marijuana Products**

Review the requirements under 3 AAC 306.520, 3 AAC 306.525, and 3 AAC 306.560.

Attach a completed copy of this page for each proposed marijuana concentrate or marijuana product.

|  |   |                                   |          |
|--|---|-----------------------------------|----------|
| <b>Product Name:</b>   | Good Vibes Ketchup Cup  |                                   |          |
| <b>Product Type:</b> Choose one.   | Other Marijuana Product   |                                   |          |
| <b>Perishable:</b> Yes/No  | Yes   | <b>Shelf Life:</b> If perishable. | 9 Months |
| <b>Intended Use:</b> Smokable/<br>edible/topical/wholesale/etc.  | Edible  |                                   |          |
| <b>Product Description:</b><br>Details must include the color, shape, and texture.   | Good Vibes Ketchup will be red in color. Good Vibes Ketchup produced in a liquid sauce form with a smooth texture. Good Vibes ketchup is a tomato based sauce used as a condiment. Available in 1mg, 2.5mg and 5mg of THC per singular pc cup for ONSITE CONSUMPTION only in the co-located retail licensed onsite consumption area.  |                                   |          |
| <b>Ingredients:</b>  | Canned peeled ground tomatoes, water, white sugar, white vinegar, onion powder, garlic powder, salt celery salt, mustard powder, ground black pepper, clove and canna-concentrate (an approved Good Titration product that will be transferred from the existing manufacturing facility to produce this product).   |                                   |          |
| <b>Standard Production Procedure and Detailed Manufacturing Process:</b>   | Pour ground tomatoes into slow cooker. Swirl 1/4 cup water in each emptied can and pour into slow cooker. Add sugar, vinegar, onion powder, garlic powder, salt, celery salt, mustard powder, black pepper, and whole clove; whisk to combine. Cook on high, uncovered, until mixture is reduced by half and very thick, 10 to 12 hours. Stir every hour or so. Smooth the texture of the ketchup using an immersion blender, about 20 seconds. Ladle the ketchup into a fine strainer and press mixture with the back of a ladle to strain out any skins and seeds. Transfer the strained ketchup to a bowl. Cool completely before tasting to adjust salt, or black pepper. After arriving at the desired taste, whisk in canna-concentrate and dispense into portion cups. |                                   |          |
| <b>Depiction:</b><br>Provide a photograph, drawing, or graphic representation of the expected appearance of the final product. |   |                                   |          |





Section 6 – Proposed Marijuana Concentrates and Marijuana Products

Review the requirements under 3 AAC 306.520, 3 AAC 306.525, and 3 AAC 306.560.

Attach a completed copy of this page for each proposed marijuana concentrate or marijuana product.

|   |                         |                                   |          |
|---|-------------------------|-----------------------------------|----------|
| <b>Product Name:</b>  | Good Vibes Ketchup      |                                   |          |
| <b>Product Type:</b> Choose one.                                | Other Marijuana Product |                                   |          |
| <b>Perishable:</b> Yes/No                                       | Yes                     | <b>Shelf Life:</b> If perishable. | 9 Months |
| <b>Intended Use:</b> Smokable/<br>edible/topical/wholesale/etc. | Edible                  |                                   |          |

|  |  |
|--|--|
| <b>Product Description:</b><br>Details must include the color, shape, and texture. | Good Vibes Ketchup will be red in color. Good Vibes Ketchup produced in a liquid sauce form with a smooth texture. Good Vibes ketchup is a tomato based sauce used as a condiment. Available in 1mg, 2.5mg and 5mg of THC per singular packet. |
|--|--|

|                     |   |
|---------------------|---|
| <b>Ingredients:</b> | Canned peeled ground tomatoes, water, white sugar, white vinegar, onion powder, garlic powder, salt celery salt, mustard powder, ground black pepper, clove and canna-concentrate (an approved Good Titration product that will be transferred from the existing manufacturing facility to produce this product). |
|---------------------|---|

|  |   |
|--|---|
| <b>Standard Production Procedure and Detailed Manufacturing Process:</b> | Pour ground tomatoes into slow cooker. Swirl 1/4 cup water in each emptied can and pour into slow cooker. Add sugar, vinegar, onion powder, garlic powder, salt, celery salt, mustard powder, black pepper, and whole clove; whisk to combine. Cook on high, uncovered, until mixture is reduced by half and very thick, 10 to 12 hours. Stir every hour or so. Smooth the texture of the ketchup using an immersion blender, about 20 seconds. Ladle the ketchup into a fine strainer and press mixture with the back of a ladle to strain out any skins and seeds. Transfer the strained ketchup to a bowl and store in a refrigerated unit. Cool completely before tasting to adjust salt, or black pepper. After arriving at the desired taste, whisk in canna-concentrate and dispensed into proper packaging. |
|--|---|

|  |  |
|--|--|
| <b>Depiction:</b><br>Provide a photograph, drawing, or graphic representation of the expected appearance of the final product. | <p>**Graphic Representation**</p>  |
|--|--|





**Section 7 – Proposed Product Packaging and Sample Labels**

Review the requirements under 3 AAC 306.520, 3 AAC 306.565, and 3 AAC 306.570.

Attach a completed copy of this page for each proposed marijuana concentrate or marijuana product.

|                      |                    |
|----------------------|--------------------|
| <b>Product Name:</b> | Good Vibes Ketchup |
| <b>Product Type:</b> | Edible             |

|  |   |
|--|---|
| <p><b>Packaging Description:</b><br/>Details must include the color(s), size, packaging materials used, total amount of THC, individual serving sizes (if multiple), and other specifics showing compliance with 3 AAC 306.565. Please include photos, drawings, or graphic representations.</p> | <p>The packet is a small bag or pouch, made from paper, foil, plastic film or another type of packing material, often used to contain single-use quantities of foods or consumer goods. The packet will come in six sizes. SIZE ONE (1); 50 packets in a single package, each packet would be 1mg of THC totaling 50mg of THC per package. SIZE TWO (2); 20 packets in a single package, each packet would be 2.5mg of THC totaling 50mg of THC per package. SIZE THREE (3); 10 packets in a single package, each packet would be 5mg of THC totaling 50mg of THC per package. SIZE FOUR (4); 1 individual packet totaling 1mg of THC. SIZE FIVE (5); 1 individual packet totaling 2.5mg of THC. SIZE SIX (6); 1 individual packet totaling 5mg of THC.</p> <div style="text-align: center;">   </div> |
|--|---|

|  |  |
|--|--|
| <p><b>Sample Labels:</b><br/>Provide sample labels showing how the labeling requirements set forth in 3 AAC 306.570 will be met.</p> | <p><b>Produced By:</b> Good Titrations<br/> <b>License Number:</b> 20832<br/> <b>Product Name:</b> Good Vibes Ketchup    <b>Strain:</b><br/> <b>Batch/Lot Number:</b>    <b>Gross Weight:</b>    <b>Net MJ Weight:</b>    <u>OZ</u>(    g)<br/> <b>Best By Date:</b>    <b>Packaging Date:</b><br/> <b>Tested By:</b>    <b>License Number:</b><br/> <b>Total THC:</b>    <b>THCA:</b>    <b>CBD:</b>    <b>CBDA:</b>    <b>CBN:</b><br/> <b>Microbial Test:</b>    <b>Pesticides:</b>    <b>Herbicides:</b><br/> <b>Fungicides:</b><br/> <b>Residual Solvent Test:</b>    <b>Contaminants Test Result:</b><br/> <b>Retailer:</b>    <b>License Number:</b><br/> <b>Alaska Safety Warning:</b> Marijuana has intoxicating effects and may be habit forming and addictive. Marijuana impairs concentration, coordination and judgment. Do not operate a vehicle or machinery under its influence. There are health risks associated with consumption of marijuana. For use only by adults twenty-one and older. Keep out of the reach of children. Marijuana should not be used by women who are pregnant or breast feeding.<br/> <b>*Keep Refrigerated*</b>    Label will include nutritional information &amp; full list of ingredients</p> |
|--|--|





**Section 6 – Proposed Marijuana Concentrates and Marijuana Products**

Review the requirements under 3 AAC 306.520, 3 AAC 306.525, and 3 AAC 306.560.

Attach a completed copy of this page for each proposed marijuana concentrate or marijuana product.

|   |                         |                                   |          |
|---|-------------------------|-----------------------------------|----------|
| <b>Product Name:</b>  | Good Vibes Mayo Cup     |                                   |          |
| <b>Product Type:</b> Choose one.                                | Other Marijuana Product |                                   |          |
| <b>Perishable:</b> Yes/No                                       | Yes                     | <b>Shelf Life:</b> If perishable. | 6 Months |
| <b>Intended Use:</b> Smokable/<br>edible/topical/wholesale/etc. | Edible                  |                                   |          |

|  |  |
|--|--|
| <b>Product Description:</b><br>Details must include the color, shape, and texture. | Good Vibes Mayo will be pale yellow in color. Good Vibes Mayo is produced in a creamy liquid form with a smooth texture. Good Vibes Mayo is a cream used as a condiment. Available in 1mg, 2.5mg and 5mg of THC per singular packet. |
|--|--|

|                     |   |
|---------------------|---|
| <b>Ingredients:</b> | Eggs, olive oil (not extra virgin), ground mustard seed, salt, freshly squeezed lemon juice (room temp. not chilled) and canna-concentrate (an approved Good Titrations product that will be transferred from the existing manufacturing facility to produce this product). |
|---------------------|---|

|  |  |
|--|--|
| <b>Standard Production Procedure and Detailed Manufacturing Process:</b> | Place ¼ cup olive oil in a food processor, add the egg, ground mustard and salt. Thoroughly combine these ingredients until they turn a pale yellow in color. With the processor going, slowly drizzle in the remaining olive oil until it has emulsified and thickened. Next add the lemon juice while the processor is running until completely incorporated. Taste of flavor accuracy, then whisk in canna-concentrate and dispense the batch into final packaging. |
|--|--|

|  |  |
|--|--|
| <b>Depiction:</b><br>Provide a photograph, drawing, or graphic representation of the expected appearance of the final product. | <p>**Graphic Representation**</p>  |
|--|--|



Section 7 – Proposed Product Packaging and Sample Labels

Review the requirements under 3 AAC 306.520, 3 AAC 306.565, and 3 AAC 306.570.

Attach a completed copy of this page for each proposed marijuana concentrate or marijuana product.

|                      |                     |
|----------------------|---------------------|
| <b>Product Name:</b> | Good Vibes Mayo Cup |
| <b>Product Type:</b> | Edible              |

|  |   |
|--|---|
| <p><b>Packaging Description:</b><br/>Details must include the color(s), size, packaging materials used, total amount of THC, individual serving sizes (if multiple), and other specifics showing compliance with 3 AAC 306.565. Please include photos, drawings, or graphic representations.</p> | <p>The pc (portion control) cup is a small 2oz container, made from paper, plastic or another type of serving material, often used to contain individual serving quantities of foods or consumer goods. The pc cup will be used for consumption by consumers onsite in the co-located and co-owned retail license in the onsite consumption area only and any product left after customer leaves will be discarded by employee's. The pc cups will come in three sizes. SIZE ONE (1); 1 individual pc cup totaling 1mg of THC. SIZE TWO (2); 1 individual pc cup totaling 2.5mg of THC. SIZE THREE (3); 1 individual pc cup totaling 5mg of THC.</p> <div style="text-align: center;">  </div> |
|--|---|

|  |  |
|--|--|
| <p><b>Sample Labels:</b><br/>Provide sample labels showing how the labeling requirements set forth in 3 AAC 306.570 will be met.</p> | <p><b>Produced By:</b> Good Titrations<br/> <b>License Number:</b> 20832<br/> <b>Product Name:</b> Good Vibes Mayo Cup      <b>Strain:</b><br/> <b>Batch/Lot Number:</b>      <b>Gross Weight:</b>      <b>Net MJ Weight:</b> <u>0Z</u> ( g)<br/> <b>Best By Date:</b>      <b>Packaging Date:</b><br/> <b>Tested By:</b>      <b>License Number:</b><br/> <b>Total THC:</b>    <b>THCA:</b>      <b>CBD:</b>    <b>CBDA:</b>      <b>CBN:</b><br/> <b>Microbial Test:</b>      <b>Pesticides:</b>      <b>Herbicides:</b><br/> <b>Fungicides:</b><br/> <b>Residual Solvent Test:</b>      <b>Contaminants Test Result:</b><br/> <b>Retailer:</b>      <b>License Number:</b><br/> <b>Alaska Safety Warning:</b> Marijuana has intoxicating effects and may be habit forming and addictive. Marijuana impairs concentration, coordination and judgment. Do not operate a vehicle or machinery under its influence. There are health risks associated with consumption of marijuana. For use only by adults twenty-one and older. Keep out of the reach of children. Marijuana should not be used by women who are pregnant or breast feeding.<br/> <b>*Keep Refrigerated*</b>      Label will include nutritional information &amp; full list of ingredients</p> |
|--|--|



Section 6 – Proposed Marijuana Concentrates and Marijuana Products

Review the requirements under 3 AAC 306.520, 3 AAC 306.525, and 3 AAC 306.560.

Attach a completed copy of this page for each proposed marijuana concentrate or marijuana product.

|   |                         |                                   |          |
|---|-------------------------|-----------------------------------|----------|
| <b>Product Name:</b>  | Good Vibes Mayo Packet  |                                   |          |
| <b>Product Type:</b> Choose one.                                | Other Marijuana Product |                                   |          |
| <b>Perishable:</b> Yes/No                                       | Yes                     | <b>Shelf Life:</b> If perishable. | 6 Months |
| <b>Intended Use:</b> Smokable/<br>edible/topical/wholesale/etc. | Edible                  |                                   |          |

|  |  |
|--|--|
| <b>Product Description:</b><br>Details must include the color, shape, and texture. | Good Vibes Mayo will be pale yellow in color. Good Vibes Mayo is produced in a creamy liquid form with a smooth texture. Good Vibes Mayo is a cream used as a condiment. Available in 1mg, 2.5mg and 5mg of THC per singular packet. |
|--|--|

|                     |   |
|---------------------|---|
| <b>Ingredients:</b> | Eggs, olive oil (not extra virgin), ground mustard seed, salt, freshly squeezed lemon juice (room temp. not chilled) and canna-concentrate (an approved Good Titrations product that will be transferred from the existing manufacturing facility to produce this product). |
|---------------------|---|

|  |  |
|--|--|
| <b>Standard Production Procedure and Detailed Manufacturing Process:</b> | Place ¼ cup olive oil in a food processor, add the egg, ground mustard and salt. Thoroughly combine these ingredients until they turn a pale yellow in color. With the processor going, slowly drizzle in the remaining olive oil until it has emulsified and thickened. Next add the lemon juice while the processor is running until completely incorporated. Taste of flavor accuracy, then whisk in canna-concentrate and dispense the batch into final packaging. |
|--|--|

|  |  |
|--|--|
| <b>Depiction:</b><br>Provide a photograph, drawing, or graphic representation of the expected appearance of the final product. | <p>**Graphic Representation**</p>  |
|--|--|



Section 7 – Proposed Product Packaging and Sample Labels

Review the requirements under 3 AAC 306.520, 3 AAC 306.565, and 3 AAC 306.570.

Attach a completed copy of this page for each proposed marijuana concentrate or marijuana product.

|                      |                        |
|----------------------|------------------------|
| <b>Product Name:</b> | Good Vibes Mayo Packet |
| <b>Product Type:</b> | Edible                 |

|  |  |
|--|--|
| <p><b>Packaging Description:</b><br/>Details must include the color(s), size, packaging materials used, total amount of THC, individual serving sizes (if multiple), and other specifics showing compliance with 3 AAC 306.565. Please include photos, drawings, or graphic representations.</p> | <p>The packet is a small bag or pouch, made from paper, foil, plastic film or another type of packing material, often used to contain single-use quantities of foods or consumer goods. The packet will come in six sizes. SIZE ONE (1); 50 packets in a single package, each packet would be 1mg of THC totaling 50mg of THC per package. SIZE TWO (2); 20 packets in a single package, each packet would be 2.5mg of THC totaling 50mg of THC per package. SIZE THREE (3); 10 packets in a single package, each packet would be 5mg of THC totaling 50mg of THC per package. SIZE FOUR (4); 1 individual packet totaling 1mg of THC. SIZE FIVE (5); 1 individual packet totaling 2.5mg of THC. SIZE SIX (6); 1 individual packet totaling 5mg of THC.</p> <div style="text-align: center;">  </div> |
|--|--|

|  |   |
|--|---|
| <p><b>Sample Labels:</b><br/>Provide sample labels showing how the labeling requirements set forth in 3 AAC 306.570 will be met.</p> | <p><b>Produced By:</b> Good Titrations<br/> <b>License Number:</b> 20832<br/> <b>Product Name:</b> Good Vibes Mayo Packet    <b>Strain:</b><br/> <b>Batch/Lot Number:</b>    <b>Gross Weight:</b>    <b>Net MJ Weight:</b>    <u>OZ( g)</u><br/> <b>Best By Date:</b>    <b>Packaging Date:</b><br/> <b>Tested By:</b>    <b>License Number:</b><br/> <b>Total THC:</b>    <b>THCA:</b>    <b>CBD:</b>    <b>CBDA:</b>    <b>CBN:</b><br/> <b>Microbial Test:</b>    <b>Pesticides:</b>    <b>Herbicides:</b><br/> <b>Fungicides:</b><br/> <b>Residual Solvent Test:</b>    <b>Contaminants Test Result:</b><br/> <b>Retailer:</b>    <b>License Number:</b><br/> <b>Alaska Safety Warning:</b> Marijuana has intoxicating effects and may be habit forming and addictive. Marijuana impairs concentration, coordination and judgment. Do not operate a vehicle or machinery under its influence. There are health risks associated with consumption of marijuana. For use only by adults twenty-one and older. Keep out of the reach of children. Marijuana should not be used by women who are pregnant or breast feeding.<br/> <b>*Keep Refrigerated*</b>    Label will include nutritional information &amp; full list of ingredients</p> |
|--|---|





**Section 6 – Proposed Marijuana Concentrates and Marijuana Products**

Review the requirements under 3 AAC 306.520, 3 AAC 306.525, and 3 AAC 306.560.

Attach a completed copy of this page for each proposed marijuana concentrate or marijuana product.

|  |   |                                   |          |
|--|---|-----------------------------------|----------|
| <b>Product Name:</b>   | Good Vibes Mustard Cup  |                                   |          |
| <b>Product Type:</b> Choose one.   | Other Marijuana Product   |                                   |          |
| <b>Perishable:</b> Yes/No  | Yes   | <b>Shelf Life:</b> If perishable. | 9 Months |
| <b>Intended Use:</b> Smokable/<br>edible/topical/wholesale/etc.  | Edible  |                                   |          |
| <b>Product Description:</b><br>Details must include the color, shape, and texture.   | Good Vibes Mustard will be yellow in color. Good Vibes Mustard produced in a liquid sauce form with a smooth texture. Good Vibes Mustard is a mustard seed based sauce used as a condiment by consumers in the onsite consumption area in the co-located and co-owned retail. Available in 1mg, 2.5mg and 5mg of THC per singular pc cup.   |                                   |          |
| <b>Ingredients:</b>  | Dry mustard powder, light brown sugar, kosher salt, tumeric, paprika, garlic powder, sweet pickle juice, water, cider vinegar, mustard seed and canna-concentrate (an approved Good Titrations product that will be transferred from the existing manufacturing facility to produce this product).  |                                   |          |
| <b>Standard Production Procedure and Detailed Manufacturing Process:</b>   | In a small, microwave-proof bowl whisk together the dry mustard, brown sugar, salt, turmeric, paprika and garlic powder. In a separate container, combine the pickle juice, water and cider vinegar and have standing by. Place the mustard seed into a spice grinder and grind for a minimum of 1 minute, stopping to pulse occasionally. Once ground, immediately add the mustard to the bowl with the dry ingredients and add the liquid mixture. Whisk to combine. Place the bowl into the microwave and heat on high for 1 minute. Remove from the microwave and puree with a stick blender for 1 minute. Pour into a glass jar or container and allow to cool uncovered. Once cool, cover and store in the refrigerator. After arriving at the desired taste, whisk in canna-concentrate and dispense into pc cups. |                                   |          |
| <b>Depiction:</b><br>Provide a photograph, drawing, or graphic representation of the expected appearance of the final product. |   |                                   |          |





**Section 6 – Proposed Marijuana Concentrates and Marijuana Products**

Review the requirements under 3 AAC 306.520, 3 AAC 306.525, and 3 AAC 306.560.

Attach a completed copy of this page for each proposed marijuana concentrate or marijuana product.

|   |                         |                                   |          |
|---|-------------------------|-----------------------------------|----------|
| <b>Product Name:</b>  | Good Vibes Mustard      |                                   |          |
| <b>Product Type:</b> Choose one.                                | Other Marijuana Product |                                   |          |
| <b>Perishable:</b> Yes/No                                       | Yes                     | <b>Shelf Life:</b> If perishable. | 9 Months |
| <b>Intended Use:</b> Smokable/<br>edible/topical/wholesale/etc. | Edible                  |                                   |          |

|  |   |
|--|---|
| <b>Product Description:</b><br>Details must include the color, shape, and texture. | Good Vibes Mustard will be yellow in color. Good Vibes Mustard produced in a liquid sauce form with a smooth texture. Good Vibes Mustard is a mustard seed based sauce used as a condiment. Available in 1mg, 2.5mg and 5mg of THC per singular packet. |
|--|---|

|                     |   |
|---------------------|---|
| <b>Ingredients:</b> | Dry mustard powder, light brown sugar, kosher salt, turmeric, paprika, garlic powder, sweet pickle juice, water, cider vinegar, mustard seed and canna-concentrate (an approved Good Titrations product that will be transferred from the existing manufacturing facility to produce this product). |
|---------------------|---|

|  |   |
|--|---|
| <b>Standard Production Procedure and Detailed Manufacturing Process:</b> | In a small, microwave-proof bowl whisk together the dry mustard, brown sugar, salt, turmeric, paprika and garlic powder. In a separate container, combine the pickle juice, water and cider vinegar and have standing by. Place the mustard seed into a spice grinder and grind for a minimum of 1 minute, stopping to pulse occasionally. Once ground, immediately add the mustard to the bowl with the dry ingredients and add the liquid mixture. Whisk to combine. Place the bowl into the microwave and heat on high. Remove from the microwave and puree with a stick blender. Pour into a glass jar or container and allow to cool uncovered. Once cool, cover and store in the refrigerator. After arriving at the desired taste, whisk in canna-concentrate and dispense the batch into final packaging. |
|--|---|

|  |   |
|--|---|
| <b>Depiction:</b><br>Provide a photograph, drawing, or graphic representation of the expected appearance of the final product. | <p><b>**Graphic Representation**</b></p>  |
|--|---|





Section 7 – Proposed Product Packaging and Sample Labels

Review the requirements under 3 AAC 306.520, 3 AAC 306.565, and 3 AAC 306.570.

Attach a completed copy of this page for each proposed marijuana concentrate or marijuana product.

|                      |                    |
|----------------------|--------------------|
| <b>Product Name:</b> | Good Vibes Mustard |
| <b>Product Type:</b> | Edible             |

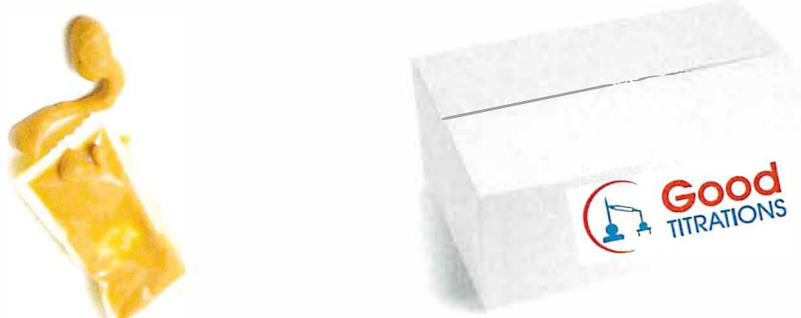
|  |  |
|--|--|
| <p><b>Packaging Description:</b><br/>Details must include the color(s), size, packaging materials used, total amount of THC, individual serving sizes (if multiple), and other specifics showing compliance with 3 AAC 306.565. Please include photos, drawings, or graphic representations.</p> | <p>The packet is a small bag or pouch, made from paper, foil, plastic film or another type of packing material, often used to contain single-use quantities of foods or consumer goods. The packet will come in six sizes. SIZE ONE (1); 50 packets in a single package, each packet would be 1mg of THC totaling 50mg of THC per package. SIZE TWO (2); 20 packets in a single package, each packet would be 2.5mg of THC totaling 50mg of THC per package. SIZE THREE (3); 10 packets in a single package, each packet would be 5mg of THC totaling 50mg of THC per package. SIZE FOUR (4); 1 individual packet totaling 1mg of THC. SIZE FIVE (5); 1 individual packet totaling 2.5mg of THC. SIZE SIX (6); 1 individual packet totaling 5mg of THC.</p> <div style="text-align: center;">  </div> |
|--|--|

|  |   |
|--|---|
| <p><b>Sample Labels:</b><br/>Provide sample labels showing how the labeling requirements set forth in 3 AAC 306.570 will be met.</p> | <p><b>Produced By:</b> Good Titrations<br/> <b>License Number:</b> 20832<br/> <b>Product Name:</b> Good Vibes Mustard    <b>Strain:</b><br/> <b>Batch/Lot Number:</b>    <b>Gross Weight:</b>    <b>Net MJ Weight:</b> <u>  OZ(  )g  </u><br/> <b>Best By Date:</b>    <b>Packaging Date:</b><br/> <b>Tested By:</b>    <b>License Number:</b><br/> <b>Total THC:</b>    <b>THCA:</b>    <b>CBD:</b>    <b>CBDA:</b>    <b>CBN:</b><br/> <b>Microbial Test:</b>    <b>Pesticides:</b>    <b>Herbicides:</b><br/> <b>Fungicides:</b><br/> <b>Residual Solvent Test:</b>    <b>Contaminants Test Result:</b><br/> <b>Retailer:</b>    <b>License Number:</b><br/> <b>Alaska Safety Warning:</b> Marijuana has intoxicating effects and may be habit forming and addictive. Marijuana impairs concentration, coordination and judgment. Do not operate a vehicle or machinery under its influence. There are health risks associated with consumption of marijuana. For use only by adults twenty-one and older. Keep out of the reach of children. Marijuana should not be used by women who are pregnant or breast feeding.<br/> <b>*Keep Refrigerated*</b>    Label will include nutritional information &amp; full list of ingredients</p> |
|--|---|





**Section 6 – Proposed Marijuana Concentrates and Marijuana Products**

Review the requirements under 3 AAC 306.520, 3 AAC 306.525, and 3 AAC 306.560.

Attach a completed copy of this page for each proposed marijuana concentrate or marijuana product.

|   |                             |                                   |          |
|---|-----------------------------|-----------------------------------|----------|
| <b>Product Name:</b>  | Good Vibes Strawberry Cream |                                   |          |
| <b>Product Type:</b> Choose one.                                | Other Marijuana Product     |                                   |          |
| <b>Perishable:</b> Yes/No                                       | Yes                         | <b>Shelf Life:</b> If perishable. | 9 Months |
| <b>Intended Use:</b> Smokable/<br>edible/topical/wholesale/etc. | Edible                      |                                   |          |

|  |   |
|--|---|
| <b>Product Description:</b><br>Details must include the color, shape, and texture. | Good Vibes Strawberry Cream cheese will be pink in color. Good Vibes Strawberry Cream cheese is produced in a creamy liquid form with a smooth texture. Good Vibes Cream cheese is a cream used as a condiment. Available in 1mg, 2.5mg and 5mg of THC per singular packet. |
|--|---|

|                     |   |
|---------------------|---|
| <b>Ingredients:</b> | Cream cheese, strawberry puree, whip topping, powder sugar and canna-concentrate. |
|---------------------|---|

|  |   |
|--|---|
| <b>Standard Production Procedure and Detailed Manufacturing Process:</b> | Using a mixer with the paddle attachment, beat cream cheese with powder sugar until all lumps are gone. Add strawberry puree until combined. Switch the paddle attachment with the whisk attachment & the whip topping. Whip until light, airy and stiff peaks form. Fold-in canna-concentrate and dispense the batch into final packaging. |
|--|---|

|  |   |
|--|---|
| <b>Depiction:</b><br>Provide a photograph, drawing, or graphic representation of the expected appearance of the final product. | <p><b>**Graphic Representation**</b></p>  |
|--|---|



Section 7 – Proposed Product Packaging and Sample Labels

Review the requirements under 3 AAC 306.520, 3 AAC 306.565, and 3 AAC 306.570.

Attach a completed copy of this page for each proposed marijuana concentrate or marijuana product.

|                      |                             |
|----------------------|-----------------------------|
| <b>Product Name:</b> | Good Vibes Strawberry Cream |
| <b>Product Type:</b> | Edible                      |

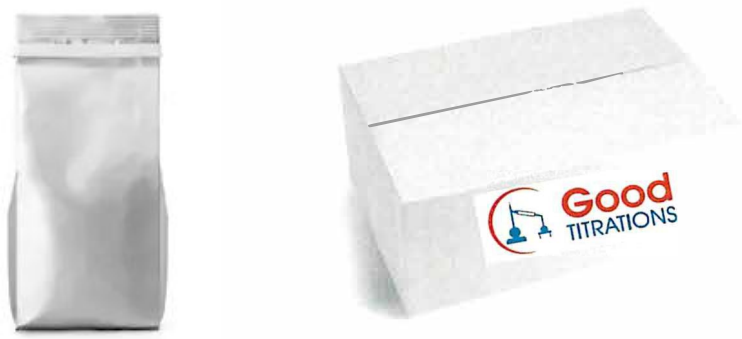
|  |  |
|--|--|
| <p><b>Packaging Description:</b><br/>Details must include the color(s), size, packaging materials used, total amount of THC, individual serving sizes (if multiple), and other specifics showing compliance with 3 AAC 306.565. Please include photos, drawings, or graphic representations.</p> | <p>The packet is a small bag or pouch, made from paper, foil, plastic film or another type of packing material, often used to contain single-use quantities of foods or consumer goods. The packet will come in six sizes. SIZE ONE (1); 50 packets in a single package, each packet would be 1mg of THC totaling 50mg of THC per package. SIZE TWO (2); 20 packets in a single package, each packet would be 2.5mg of THC totaling 50mg of THC per package. SIZE THREE (3); 10 packets in a single package, each packet would be 5mg of THC totaling 50mg of THC per package. SIZE FOUR (4); 1 individual packet totaling 1mg of THC. SIZE FIVE (5); 1 individual packet totaling 2.5mg of THC. SIZE SIX (6); 1 individual packet totaling 5mg of THC.</p> <div style="text-align: center;">  </div> |
|--|--|

|  |  |
|--|--|
| <p><b>Sample Labels:</b><br/>Provide sample labels showing how the labeling requirements set forth in 3 AAC 306.570 will be met.</p> | <p><b>Produced By:</b> Good Titrations<br/> <b>License Number:</b> 20832<br/> <b>Product Name:</b> Good Vibes Strawberry Cream <b>Strain:</b><br/> <b>Batch/Lot Number:</b>    <b>Gross Weight:</b>    <b>Net MJ Weight:</b>    <u>OZ(    g)</u><br/> <b>Best By Date:</b>    <b>Packaging Date:</b><br/> <b>Tested By:</b>    <b>License Number:</b><br/> <b>Total THC:</b>    <b>THCA:</b>    <b>CBD:</b>    <b>CBDA:</b>    <b>CBN:</b><br/> <b>Microbial Test:</b>    <b>Pesticides:</b>    <b>Herbicides:</b><br/> <b>Fungicides:</b><br/> <b>Residual Solvent Test:</b>    <b>Contaminants Test Result:</b><br/> <b>Retailer:</b>    <b>License Number:</b><br/> <b>Alaska Safety Warning:</b> Marijuana has intoxicating effects and may be habit forming and addictive. Marijuana impairs concentration, coordination and judgment. Do not operate a vehicle or machinery under its influence. There are health risks associated with consumption of marijuana. For use only by adults twenty-one and older. Keep out of the reach of children. Marijuana should not be used by women who are pregnant or breast feeding.<br/> <b>*Keep Refrigerated*</b>    Label will include nutritional information &amp; full list of ingredients</p> |
|--|--|



**Section 6 – Proposed Marijuana Concentrates and Marijuana Products**

Review the requirements under 3 AAC 306.520, 3 AAC 306.525, and 3 AAC 306.560.

Attach a completed copy of this page for each proposed marijuana concentrate or marijuana product.

|  |   |                                   |          |
|--|---|-----------------------------------|----------|
| <b>Product Name:</b>   | Good Vibes Whipped Butter <i>Cup</i>  |                                   |          |
| <b>Product Type:</b> Choose one.   | Other Marijuana Product   |                                   |          |
| <b>Perishable:</b> Yes/No  | Yes   | <b>Shelf Life:</b> If perishable. | 9 Months |
| <b>Intended Use:</b> Smokable/<br>edible/topical/wholesale/etc.  | Edible  |                                   |          |
| <b>Product Description:</b><br>Details must include the color, shape, and texture.   | Good Vibes Whipped Butter will be yellowish white in color. Good Vibes Whipped Butter produced in a liquid form with a smooth texture chilled to harden. Good Vibes Whipped Butter is used as a condiment onsite consumption by customers in the co-located co-owned retail consumption area. For example, when a customer orders a muffin they are provided a non-infused muffin and a side of infused whipped butter. The whipped butter comes with the order as a part of the muffin order. Available in 1mg, 2.5mg and 5mg of THC per singular cup. |                                   |          |
| <b>Ingredients:</b>  | Bulk salted butter, whole milk and canna-concentrate (an approved Good Titrations product that will be transferred from the existing manufacturing facility to produce this product).   |                                   |          |
| <b>Standard Production Procedure and Detailed Manufacturing Process:</b>   | Beat milk and butter together until light and fluffy. Then whisk in canna-concentrate and dispense the batch into final packaging for cooling.  |                                   |          |
| <b>Depiction:</b><br>Provide a photograph, drawing, or graphic representation of the expected appearance of the final product. |   |                                   |          |





**Section 7 – Proposed Product Packaging and Sample Labels**

Review the requirements under 3 AAC 306.520, 3 AAC 306.565, and 3 AAC 306.570.

Attach a completed copy of this page for each proposed marijuana concentrate or marijuana product.

|                      |                               |
|----------------------|-------------------------------|
| <b>Product Name:</b> | Good Vibes Whipped Butter Cup |
| <b>Product Type:</b> | Edible                        |

|  |   |
|--|---|
| <p><b>Packaging Description:</b><br/>Details must include the color(s), size, packaging materials used, total amount of THC, individual serving sizes (if multiple), and other specifics showing compliance with 3 AAC 306.565. Please include photos, drawings, or graphic representations.</p> | <p>The pc (portion control) cup is a small 2oz container, made from paper, plastic or another type of serving material, often used to contain individual serving quantities of foods or consumer goods. The pc cup will be used for in-house usage only and any product left after customer leaves will be discarded by employee's. The pc cup will come in three sizes. <b>SIZE ONE (1);</b> 1 individual pc cup totaling 1mg of THC. <b>SIZE TWO (2);</b> 1 individual pc cup totaling 2.5mg of THC. <b>SIZE THREE (3);</b> 1 individual pc cup totaling 5mg of THC.</p> <div style="text-align: center;">  </div> |
|--|---|

|  |  |
|--|--|
| <p><b>Sample Labels:</b><br/>Provide sample labels showing how the labeling requirements set forth in 3 AAC 306.570 will be met.</p> | <p><b>Produced By:</b> Good Titrations<br/> <b>License Number:</b> 20832<br/> <b>Product Name:</b> Good Vibes Whip Butter Strain:<br/> <b>Batch/Lot Number:</b>    <b>Gross Weight:</b>    <b>Net MJ Weight:</b>    <u>OZ(</u> g)<br/> <b>Best <u>By</u> Date:</b>    <b>Packaging Date:</b><br/> <b>Tested By:</b>    <b>License Number:</b><br/> <b>Total THC:</b>    <b>THCA:</b>    <b>CBD:</b>    <b>CBDA:</b>    <b>CBN:</b><br/> <b>Microbial Test:</b>    <b>Pesticides:</b>    <b>Herbicides:</b><br/> <b>Fungicides:</b><br/> <b>Residual Solvent Test:</b>    <b>Contaminants Test Result:</b><br/> <b>Retailer:</b>    <b>License Number:</b><br/> <b>Alaska Safety Warning:</b> Marijuana has intoxicating effects and may be habit forming and addictive. Marijuana impairs concentration, coordination and judgment. Do not operate a vehicle or machinery under its influence. There are health risks associated with consumption of marijuana. For use only by adults twenty-one and older. Keep out of the reach of children. Marijuana should not be used by women who are pregnant or breast feeding.<br/> <b>*Keep Refrigerated*</b>    Label will include nutritional information &amp; full list of ingredients</p> |
|--|--|





## Alaska Marijuana Control Board

# Form MJ-02: Premises Diagram

### What is this form?

A detailed diagram of the proposed licensed premises is required for all marijuana establishment license applications, per 3 AAC 306.020(b)(8). **All areas designated as the licensed premises of a single license must be contiguous. All diagrams must have the licensed premises area labeled, and outlined or shaded as appropriate.**

### What must be submitted with this form?

Applicants must attach multiple diagrams to this form, including (as applicable):

- **Diagram 1:**  
a diagram showing only the licensed premises areas that will be ready to be **operational at the time of your preliminary inspection** and license issuance;
- **Diagram 2:**  
if different than Diagram 1, a diagram outlining **all areas for which the licensee has legal right of possession** (a valid lease or deed), and clearly showing those areas' relationship to the current proposed licensed premises (*details of any planned expansion areas do not need to be included; a complete copy of Form MJ-14: Licensed Premises Diagram Change must be submitted and approved before any planned expansion area may be added to the licensed premises*);
- **Diagram 3:**  
a **site plan or as-built of the entire lot**, showing all structures on the property and clearly indicating which area(s) will be part of the licensed premises;
- **Diagram 4:**  
an **aerial photo of the entire lot and surrounding lots**, showing a view of the entire property and surrounding properties, and clearly indicating which area(s) will be part of the licensed premises (*this can be obtained from sources like Google Earth*); and
- **Diagram 5:**  
a diagram of the **entire building in which the licensed premises is located**, clearly distinguishing the licensed premises from unlicensed areas and/or premises of other licenses within the building. If your proposed licensed premises is located within a building or building complex that contains multiple business and/or tenants, please provide the addresses and/or suite numbers of the other businesses and/or tenants (*a separate diagram is not required for an establishment that is designating the entire building as a single licensed premises*).

**This form, and all necessary diagrams that meet the requirements on Page 2 of this form, must be completed and submitted to AMCO's main office before any new or transfer license application will be considered complete.**

### Section 1 – Establishment Information

Enter information for the business seeking to be licensed, as identified on the license application.

|                    |  |               |        |      |       |
|--------------------|--|---------------|--------|------|-------|
| Licensee:          | FSE, Inc                                 | MJ License #: | 20832  |      |       |
| License Type:      | Marijuana Product Manufacturing Facility |               |        |      |       |
| Doing Business As: | GOOD TITRATIONS                          |               |        |      |       |
| Premises Address:  | 506 Merhar Ave                           |               |        |      |       |
| City:              | Fairbanks                                | State:        | Alaska | ZIP: | 99701 |



# Form MJ-02: Premises Diagram

## Section 2 – Required Information

For your security, do not include locations of security cameras, motion detectors, panic buttons, and other security devices. Items marked with a double asterisks (\*\*\*) are only required for those retail marijuana establishments that are also applying for an onsite consumption endorsement.

The following details must be included in all diagrams:

- License number and DBA
- Legend or key
- Color coding
- Licensed Premises Area Labeled and Shaded, or Outlined as appropriate
- Dimensions
- Labels
- True north arrow

The following additional details must be included in Diagram 1:

- Surveillance room
- Restricted access areas
- Storage areas
- Entrances, exits, and windows
- Walls, partitions, and counters
- Any other areas that must be labeled for specific license or endorsement types
- \*\* Serving area(s)
- \*\*Employee monitoring area(s)
- \*\*Ventilation exhaust points, if applicable

The following additional details must be included in Diagram 2:

- Areas of ingress and egress
- Entrances and exits
- Walls and partitions

The following additional details must be included in Diagrams 3 and 4:

- Areas of ingress and egress
- Cross streets and points of reference

The following additional details must be included in Diagram 5:

- Areas of ingress and egress
- Entrances and exits
- Walls and partitions
- Cross streets and points of reference

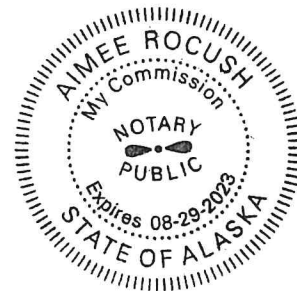

I declare under penalty of unsworn falsification that I have attached all necessary diagrams that meet the above requirements, and that this form, including all accompanying schedules, statements, and depictions is true, correct, and complete.

[Signature]  
Signature of licensee

Shawn Tacke  
Printed name of licensee

Aimee Rocush  
Notary Public in and for the State of Alaska

My commission expires: 8/29/2023

Subscribed and sworn to before me this 20 day of December, 2019.



# Diagram 5 1+2+5

6 Month Business Record Storage

Video Surveillance & Recording Storage

## SHEET NOTES (PLANS)

- DIMENSIONS ARE TO FACE OF STUD, FACE OF CONCRETE, GRID LINES, AND CENTER LINE OF WINDOW ASSEMBLIES UNLESS OTHERWISE NOTED.
- CONSTRUCTION ASSEMBLY DESCRIPTIONS, SEE A1.0.
- PRODUCT SPECIFICATIONS, SEE A1.0.
- ACCESSIBILITY AND ADA DETAILS, SEE A6.0.
- OPERABLE PARTS OF LIGHTING, ENVIRONMENTAL SECURITY CONTROLS AND ELECTRICAL RECEPTACLES SHALL BE MOUNTED BETWEEN 15" AND 48" ABOVE FINISHED FLOOR.
- ALL FAUCETS TO HAVE LEVER HANDLES.
- REMOVE EXISTING TILE, GRIND AND POLISH EXISTING CONCRETE, TYP THROUGHOUT. IF ANY TILE REMAINS OR IS REPLACED DURING CONSTRUCTION, VERIFY ADA COMPLIANCE AT FLOOR TRANSITION PER 216.0.

## PHASING LEGEND

- EXISTING TO REMAIN
- REMOVED DURING DEMO PHASE (DEMO PLANS ONLY)
- NEW CONSTRUCTION (NEW PLANS ONLY)

- proposed Licensed premises
- Restricted Access Area
- Shared Non-Restricted Restroom
- Shared Video Surveillance & Recording Storage

- Cultivation License # 20829
- Retail License # 20827



PERMIT SET REVISIONS (REFERENCE ONLY)

Good Titrations License # 20829 506 Merhar Avenue Fairbanks, AK Manufacturing

| # | Date | Description |
|---|------|-------------|
| 1 |      |             |

10.14.19 Date  
SM Drawn By

Floor Plan

# A2.0

Copyright 2019 ©  
If this drawing is less than 22" x 34", it has been reduced. Scale accordingly. Half size at 11" x 17"

AMCO Received 2/27/2020

Plot Date: 10/14/2019 9:29:32 PM Revit File: My Drive\HARKA - PROJECT Files\Good Titrations\Dispensary\Revit\Good Titrations\_18.10.12.rvt

1 GROUND FLOOR PLAN  
A2.0 SCALE: 3/16" = 1'-0"



# GOOD TITRATIONS

## GENERAL NOTES

- CONTRACTOR SHALL VERIFY ALL EXISTING CONDITIONS AND DIMENSIONS PRIOR TO CONSTRUCTION AND SHALL NOTIFY DESIGNER OF ANY DEVIATIONS FROM DRAWINGS PRIOR TO CONTINUATION OF WORK.
- CONTRACTOR SHALL NOTIFY DESIGNER OF ANY NEED FOR DESIGN CHANGES DUE TO FIELD CONDITIONS OR OBSERVATIONS PRIOR TO CONTINUING WORK.
- WRITTEN DIMENSIONS HAVE PRECEDENCE OVER SCALED DIMENSIONS. DO NOT SCALE THE DRAWINGS.
- DIMENSIONS ARE TO FACE OF STUD, FACE OF CONCRETE, GRID LINES, AND CENTER LINE OF WINDOW ASSEMBLIES UNLESS OTHERWISE NOTED.
- SAFETY GLAZING IS REQUIRED WHERE GLASS IS WITHIN 18" OF THE FLOOR AND 24" OF DOORS. SEE 2017 ORSC SEC. R308 FOR ADDITIONAL SAFETY REQUIREMENTS.
- ALL MATERIALS AND WORK SHALL CONFORM TO ALL GOVERNING CODES AND REGULATIONS.
- ALL WORK TO BE DONE IN ACCORDANCE WITH THE LATEST CODES WITH LOCAL AMENDMENTS AND ORDINANCES AND GOOD STANDARD PRACTICE. CONTRACTOR TO COORDINATE ALL DIMENSIONS, SIZING AND OPENINGS WITH ALL TRADES. CONTRACTOR TO VERIFY ALL CONNECTOR SIZES TO INSURE PROPER FIT.
- ALL MATERIALS AND PRODUCTS SHALL BE INSTALLED IN ACCORDANCE WITH THE MANUFACTURER'S WRITTEN INSTRUCTIONS.
- FRAMING CONTRACTOR TO VERIFY ALL ROUGH OPENING SIZES AND DETAILS FOR DOORS, WINDOWS, EXHAUST, FANS, AND VENTS.
- CONTRACTOR SHALL PROVIDE ALL NECESSARY TEMPORARY BRACING, SHORING, GUYING OR OTHER MEANS TO AVOID EXCESSIVE STRESSES AND TO HOLD STRUCTURAL ELEMENTS IN PLACE DURING CONSTRUCTION.
- ARCHITECT NOT RESPONSIBLE FOR WATER PENETRATION OF EXISTING ROOFING, FLASHING, OR PARAPETS.
- WHEN WORK NOT SPECIFICALLY CALLED OUT IS REQUIRED TO COMPLETE THE PROJECT, IT SHALL BE OF THE BEST MATERIAL AND WORKMANSHIP.
- CONTRACTOR SHALL TAKE ALL THE NECESSARY PRECAUTIONARY MEASURES TO PROTECT THE PUBLIC AND ADJACENT PROPERTIES FROM DAMAGE THROUGHOUT CONSTRUCTION. CONTRACTOR ASSUMES ALL LIABILITY FOR DAMAGES INCURRED DURING CONSTRUCTION.
- CONTRACTOR SHALL ESTABLISH AND VERIFY ALL OPENINGS AND INSERTS FOR MECHANICAL, ELECTRICAL, AND PLUMBING WITH APPROPRIATE TRADES.
- THE STARTING OF WORK BY THE GENERAL CONTRACTOR OR ANY SUBCONTRACTOR SHALL BE CONSIDERED PRIMA FACIE EVIDENCE THAT THEY HAVE INSPECTED AND ACCEPTED ALL CONDITIONS INVOLVED IN THE WORK AND FIND THEM SATISFACTORY.
- CONTRACTOR SHALL THE NEW UTILITIES INTO PRIVATE & PUBLIC LINES AS REQUIRED BY PUBLIC, PRIVATE UTILITIES OR COUNTY.
- CONTRACTOR SHALL COORDINATE WORK OF MECH. AND ELEC. SUBCONTRACTORS AND NOTIFY DESIGNER OF ANY CONFLICTS OR VARIATIONS FROM I.R.C. REQUIREMENTS. ALL WORK TO CONFORM TO ALL RELEVANT CODES AND REGULATIONS.
- CONTRACTOR SHALL BE RESPONSIBLE FOR OBTAINING ALL DEFERRED AND TRADE PERMITS.
- CONTRACTOR SHALL VERIFY AND CONFIRM ALL SIZES & DIMENSIONS PRIOR TO ORDERING.
- WHEN POSSIBLE, USE PRODUCTS MADE IN THE UNITED STATES. EXAMPLE OF A COMPREHENSIVE LIST OF PRODUCTS MADE IN THE USA CAN BE FOUND AT: <http://www.americansworking.com/buildingmaterial.html>

## LOW-CARBON NOTES

- ANNULAR SPACES AROUND PIPES, ELECTRIC CABLES, CONDUITS OR OTHER OPENINGS IN PLATES AT EXTERIOR WALLS SHALL BE PROTECTED AGAINST THE PASSAGE OF RODENTS BY CLOSING SUCH OPENINGS WITH CEMENT MORTAR, CONCRETE MASONRY OR SIMILAR ACCEPTABLE METHOD.
- A MINIMUM OF 50 PERCENT OF THE CONSTRUCTION WASTE GENERATED AT THE SITE SHALL BE DIVERTED TO RECYCLE OR SALVAGE.
- GAS FIREPLACES SHALL BE A DIRECT-VENT SEALED-COMBUSTION TYPE. WOOD/PELLET STOVES SHALL COMPLY WITH US EPA PHASE II EMISSION LIMITS.
- DUCT AND VENT OPENINGS SHALL BE COVERED DURING CONSTRUCTION.
- ADHESIVES, SEALANTS AND CAULKS SHALL BE COMPLIANT LOW OR NO VOC.
- PAINTS, STAINS, AND OTHER COATINGS SHALL BE COMPLIANT LOW OR NO VOC.
- MOISTURE CONTENT OF BUILDING MATERIALS USED IN ENCLOSED WALL AND FLOOR FRAMING IS CHECKED BEFORE ENCLOSURE AND CANNOT EXCEED 19%.
- HVAC SYSTEM INSTALLERS ARE TRAINED AND CERTIFIED IN THE PROPER INSTALLATION OF HVAC SYSTEMS.
- USE FSC LOCAL ENVIRONMENTALLY CERTIFIED, SUSTAINABLY-SOURCED PRODUCTS - FOR MORE INFORMATION AND RESOURCES VISIT SUSTAINABLE NW: <http://www.sustainablenorthwest.org/>
- MINIMIZE USE OF CONCRETE WHERE ALTERNATIVE IS POSSIBLE.

## SYMBOLS

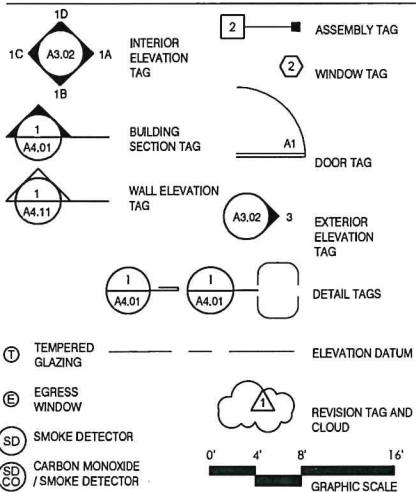

## ZONING INFORMATION

|  | CODE       | PROPOSED      |
|--|------------|---------------|
| MAX HEIGHT (INDOOR SMALL MARIJUANA CULTIVATION FACILITY) | 35'-0" MAX | < 35'-0"      |
| REQUIRED YARDS   | NOT REQ'D  | NO CHANGES    |
| MAX HEIGHT   | UNLIMITED  | NO CHANGES    |
| MAX LOT COVERAGE   | 100%       | NO CHANGES    |
| SMALL INDOOR CULTIVATION                                 | PERMITTED  | ACCESSORY USE |

## PARKING

RESTAURANT: 1 SPACE PER 3 SEATS: 47 SEATS / 3 = 16 SPACES  
 STORE: 1 SPACE PER 200 SF SALES AREA: 837 SF / 200 = 4 SPACES  
 ALL OTHER COMMERCIAL/INDUSTRIAL: 3 SPACES PER 4 EMPLOYEES:  
 (22 EMPLOYEES / 4) X 3 = 17 SPACES  
 ADA PARKING: 1 ADA STALL PER 50 SPACES  
 37 SPACES REQUIRED

## STORMWATER MANAGEMENT

NO CHANGES TO IMPERVIOUS AREA.

## BUILDING INFORMATION

| TOTAL    | EXISTING | PROPOSED   |
|----------|----------|------------|
| 7,800 SF | 7,800 SF | NO CHANGES |

AREA OF MARIJUANA CULTIVATION FACILITY: 1,042 SF, ALL INDOOR

## SITE INFORMATION

|                   |   |
|-------------------|---|
| ADDRESS           | 508 MERHAR AVE, FAIRBANKS, AK 99701       |
| COUNTY            | FAIRBANKS NORTH STAR                      |
| LEGAL DESCRIPTION | LOT 3, TR A, BENTLEY BROTHERS SUBDIVISION |
| LOT SIZE          | .96 ACRES (41,782 sq ft)                  |
| BASE ZONE         | GU-1 (GENERAL USE)                        |

## JOB DESCRIPTION

TENANT IMPROVEMENT OF EXISTING A-2 RESTAURANT TO NON-SEPARATED MIXED OCCUPANCY A-2 CAFE AND KITCHEN, M MARIJUANA RETAIL AND F-1 SMALL INDOOR MARIJUANA CULTIVATION. NO CHANGES TO EXTERIOR ENVELOPE.

TO COMPLY WITH 2015 INTERNATIONAL BUILDING CODE AND CITY OF FAIRBANKS LOCAL AMENDMENTS TO THE 2015 INTERNATIONAL BUILDING CODE.

VALUATION: \$130,000

## VICINITY MAP

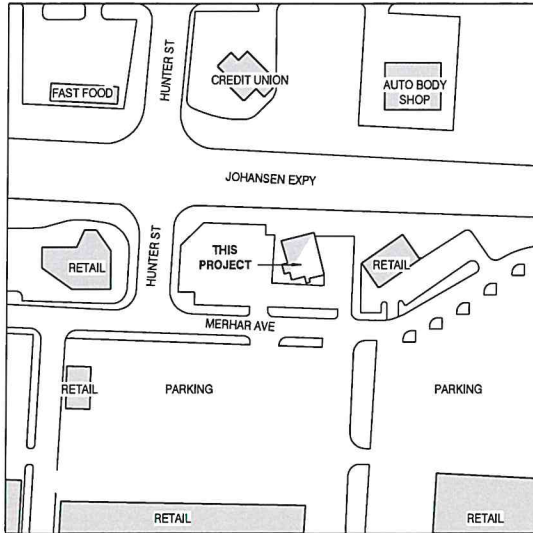

## ABBREVIATIONS

|         |                         |         |                           |         |                             |         |  |
|---------|-------------------------|---------|---------------------------|---------|-----------------------------|---------|--|
| # & C   | NUMBER AND CENTERLINE   | EA      | EACH EXPANSION JOINT      | IBC     | INTERNATIONAL BUILDING CODE | PERF    | PERFORATED, PERFORATE                          |
| A/C     | AIR CONDITIONING        | EJ      | ELEVATION                 | IN      | INCH                        | PLAM    | PLASTIC LAMINATE PLATE, PROPERTY LINE          |
| ADDL    | ADDITIONAL              | EL      | ELECTRICAL                | INFO    | INFORMATION                 | PLYWD   | PLYWOOD  |
| ADJ     | ADJUSTABLE              | ELEV    | ELEVATOR                  | INSUL   | INSULATE(D)                 | PNL     | PANEL  |
| ADU     | ACCESSORY DWELLING UNIT | EQIP    | EQUIPMENT                 | INT     | INTERIOR                    | PR      | PAINT  |
| AFF     | ABOVE FINISH FLOOR      | EQ      | EQUAL                     | JAN     | JANITOR'S CLOSET            | PR      | PAIR   |
| ALUM    | ALUMINUM                | (E)     | EXISTING                  | JST     | JOIST                       | PRE-FIN | PRE-FINISHED                                   |
| ALT     | ALTERNATE               | EXIST   | EXISTING                  | KIT     | KITCHEN                     | PRE-PR  | PRE-PRIMED                                     |
| APT     | APARTMENT               | EXT     | EXTERIOR                  | LAM     | LAMINATE                    | PT      | PRESSURE TREATED                               |
| ARCH    | ARCHITECT(URAL)         | FCB     | FIBER CEMENT BOARD        | LAW     | LAVATORY                    | R       | RADIUS   |
| AWN     | AWNING                  | FD      | FLOOR DRAIN               | LAWN    | LAUNDRY                     | RD      | ROOF DRAIN                                     |
| BD      | BOARD                   | FEC     | FIRE EXTINGUISHER CABINET | LGT     | LIGHT                       | REF     | REFERENCE                                      |
| BR      | BEDROOM                 | FIN     | FINISH                    | LIN     | LINOLEUM                    | REFR    | REFRIGERATOR                                   |
| BRDM    | BEDROOM                 | FLR     | FLOOR                     | MAINT   | MAINTENANCE                 | REQD    | REQUIRED                                       |
| BLDG    | BUILDING                | FND     | FOUNDATION                | MATL    | MATERIAL                    | REST    | RESTROOM                                       |
| BLKG    | BLOCKING                | FOF     | FACE OF FINISH            | MAX     | MAXIMUM                     | REV     | REVISION                                       |
| BLW     | BELOW                   | FOF     | FACE OF STUD              | MECH    | MECHANICAL                  | RM      | ROOM   |
| BM      | BEAM                    | FOS     | FACE OF STUD              | MEMB    | MEMBRANE                    | RO      | ROUGH OPENING                                  |
| BO/B.O. | BOTTOM OF               | FRM     | FRAMING                   | MFR     | MANUFACTURER                | SD      | SMOKE DETECTOR                                 |
| BOT     | BOTTOM                  | MIR     | MIRROR                    | MIN     | MINIMUM                     | SF      | SQUARE FOOT                                    |
| BSMT    | BASEMENT                | MISC    | MISCELLANEOUS             | MIR     | MIRROR                      | SHTHG   | SHEATHING                                      |
| CLG     | CEILING                 | MO      | MASONRY OPENING           | MO      | MASONRY OPENING             | SS      | STAINLESS STEEL                                |
| CLR     | CLEAR(ANCE)             | MTL     | METAL                     | MTL     | METAL                       | STD     | STANDARD                                       |
| CMU     | CONCRETE UNIT MASONRY   | (N)     | NEW                       | NA      | NOT APPLICABLE              | STL     | STEEL  |
| CPT     | CARPET                  | N       | NORTH                     | NA      | NOT APPLICABLE              | STOR    | STORAGE  |
| COL     | COLUMN                  | NIS     | NOT IN SCOPE              | NR      | NON RATED                   | STC     | SOUND TRANSMISSION CLASS                       |
| COLS    | COLUMNS                 | NO      | NUMBER                    | NTS     | NOT TO SCALE                | STRUCT  | STRUCTURAL                                     |
| CONT    | CONTINUOUS              | OC/O.C. | ON CENTER OCCUPANT(S)     | OC/O.C. | ON CENTER OCCUPANT(S)       | T & G   | TONGUE & GROOVE                                |
| CONC    | CONCRETE                | OLF     | OCCUPANCY(IES)            | OLF     | OCCUPANT LOAD FACTOR        | TB      | TOWEL BAR                                      |
| CORR    | CORRIDOR                | OPP     | OCCUPANT LOAD FACTOR      | OPP     | OPPOSITE                    | THK     | THICK, THICKNESS                               |
| D       | DRYER                   | ORD     | OVERFLOW ROOF DRAIN       | ORD     | OVERFLOW ROOF DRAIN         | TO/I.O. | TOP OF TOILET PAPER                            |
| DBL     | DOUBLE                  |         |                           |         |                             | TP      | TYPICAL  |
| DIA     | DIAMETER                |         |                           |         |                             | UL      | UNDERWRITERS LABORATORY UNLESS NOTED OTHERWISE |
| DIM     | DIMENSION               |         |                           |         |                             | VERT    | VERTICAL                                       |
| DN      | DOWN                    |         |                           |         |                             | VS      | VERSUS   |
| DR      | DOOR                    |         |                           |         |                             | W       | WASHER   |
| DS      | DOWNSPOUT               |         |                           |         |                             | WC      | WATER CLOSET                                   |
| DW      | DISHWASHER              |         |                           |         |                             | WD      | WOOD   |
| DWG     | DRAWING                 |         |                           |         |                             | WH      | WATER HEATER                                   |
|         |                         |         |                           |         |                             | WIN     | WINDOW   |
|         |                         |         |                           |         |                             | WRB     | WEATHER RESISTIVE BARRIER                      |
|         |                         |         |                           |         |                             | WP      | WATERPROOF                                     |
|         |                         |         |                           |         |                             | WR      | WATER RESISTANT                                |

## TRADE PERMITS

MECHANICAL, ELECTRICAL, PLUMBING, FIRE SPRINKLER AND SIGN PERMITS TO BE OBTAINED SEPARATELY.

## PROJECT TEAM

### OWNER

HAPPY PEPPER, LLC  
 1770 DONALD AVE  
 FAIRBANKS AK 99701

907-328-8529  
[info@goodtitrations.com](mailto:info@goodtitrations.com)

### ARCHITECT

HARKA ARCHITECTURE, LLC  
 107 SE WASHINGTON ST, SUITE 740  
 PORTLAND, OR 97214

CONTACT: PATRICK DONALDSON  
 503-975-9471  
[patrik@harka.com](mailto:patrik@harka.com)

### STRUCTURAL

NELSON ENGINEERING  
 155 BIDARCA STREET  
 KENAI, ALASKA 99611

CONTACT: ZACK RININGER  
 907-283-3583  
[ZRININGER@ALASKA.NET](mailto:ZRININGER@ALASKA.NET)

## DRAWING SHEET INDEX

### ARCHITECTURAL

- A0.0 Project Info, Zoning / Code, & Site Plan
- A0.1 Life Safety Info & Plans
- A1.0 Assemblies, Schedules & Demo Plan
- A2.0 Floor Plan
- A2.1 Reflecting Ceiling Plan
- A3.0 Elevations
- A5.0 Enlarged Plans
- A5.1 Sections & Details
- A6.0 Accessibility Details

### INTERIOR DESIGN

- ID1.0 Finish / Material Schedules & Reference Plan
- ID2.0 Fixture / Furniture Plan
- ID3.0 Lighting Plan
- ID4.0 Interior Elevations
- ID4.1 Interior Elevations
- ID5.0 Interior Details
- ID5.1 Interior Details
- ID5.2 Interior Details

### STRUCTURAL

- S1.1 Notes and Specifications
- S1.2 Special Inspection
- S2.1 First Floor Framing Plan
- S3.1 Details

Right to possession  
 proposed licensed premises.  
 Diagram 3

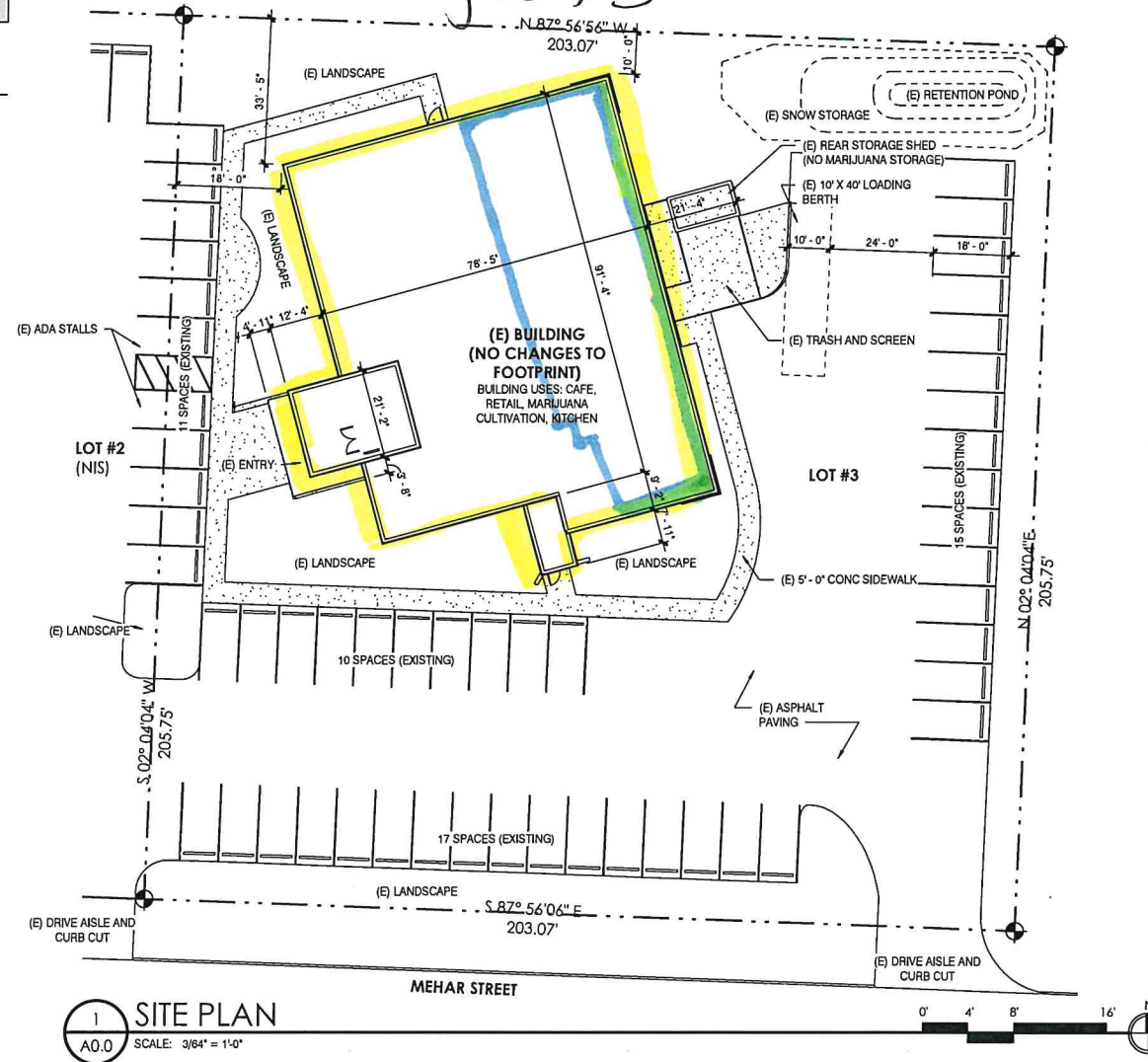

PERMIT SET REVISIONS (REFERENCE ONLY)

Good Titrations License #20832 506 Merhar Avenue Fairbanks, AK Manufacturing

| # | Date     | Description |
|---|----------|-------------|
| 1 | 09.09.19 | Date        |
|   | SM       | Drawn By    |

Project Info, Zoning / Code, & Site Plan

# A0.0

Copyright 2019 ©  
 If this drawing is less than 22" x 34", it has been reduced. Scale accordingly. Half size at 11" x 17".

AMCO Received 2/24/2020







**ORDINANCE NO. 6127**

**AN ORDINANCE AUTHORIZING CONVEYANCE OF A TEMPORARY  
CONSTRUCTION EASEMENT ON CITY-OWNED PARCEL TCE-11 AS REQUESTED  
BY THE ALASKA DEPARTMENT OF TRANSPORTATION & PUBLIC FACILITIES  
FOR THE WENDELL AVENUE BRIDGE PROJECT**

**WHEREAS**, the Alaska Department of Transportation & Public Facilities (ADOT&PF) has funding for the Wendell Avenue Bridge Project, State Project number Z632910000; and

**WHEREAS**, the Wendell Avenue Bridge Project will provide for improvements and upgrades to that bridge; and

**WHEREAS**, this project will require the State of Alaska to acquire a temporary construction easement on a parcel of city property referred to as TCE-11, containing 1,532 square feet, as more fully described and shown in Exhibit A attached to this ordinance; and

**WHEREAS**, it is the sense of the Council that conveyance of this temporary easement to ADOT&PF is in the best interest of the public and of mutual benefit to the State and the City.

**NOW, THEREFORE, BE IT ENACTED BY THE CITY COUNCIL OF THE CITY OF FAIRBANKS, ALASKA, as follows:**

**SECTION 1.** That the Mayor is hereby authorized to execute the easement document attached, and the City Clerk is authorized and directed to attest and affix the City Seal to the easement document.

**SECTION 2.** That the conveyance of the easement is subject to the 30-day permissive referendum period as required under FGC Sec. 70-42 and in accordance with the Fairbanks City Charter.

**SECTION 3.** That the effective date of this ordinance will be the \_\_\_\_ day of April 2020.

\_\_\_\_\_  
Jim Matherly, City Mayor

AYES:  
NAYS:  
ABSENT:  
ADOPTED:

ATTEST:

APPROVED AS TO FORM:

---

D. Danyielle Snider, CMC, City Clerk

---

Paul J. Ewers, City Attorney



Exhibit "A" to Ordinance No. 6127

|   |  |
|---|--|
|  <p>STATE OF ALASKA<br/>DEPARTMENT OF TRANSPORTATION<br/>AND PUBLIC FACILITIES</p> <p><b>TEMPORARY CONSTRUCTION EASEMENT</b><br/>(Standard/Partial Property)</p> | <p>PROJECT NAME: <u>WENDELL AVENUE BRIDGE</u></p> <p>STATE PROJECT #: <u>Z632910000</u></p> <p>FEDERAL-AID PROJECT #: _____</p> <p>PARCEL #: <u>TCE-11</u></p> |
|   |  |

The GRANTOR, CITY OF FAIRBANKS, whose mailing address is 800 Cushman Street, Fairbanks, AK 99701, for and in consideration of TEN DOLLARS (\$10.00), and other valuable consideration, in hand paid, conveys and warrants to the GRANTEE, STATE OF ALASKA, DEPARTMENT OF TRANSPORTATION & PUBLIC FACILITIES, whose mailing address is 2301 Peger Road, Fairbanks, AK 99709, its successors and assignees, an unrestricted temporary easement, over, and across the following-described tract of land located within Section 11, Township 1 South, Range 1 West, Fairbanks Recording District, Fourth Judicial District, State of Alaska: That part of the following described tract of land:

**TCE-11**

That parcel of land, for use as a Temporary Construction Easement, as required for the Wendell Avenue Bridge Construction, State of Alaska DOT&PF Project No. Z632910000, as depicted on the attached plat, Parcel No. TCE-11; said parcel being a portion of that property delineated in the conveyance document recorded February 2, 1982, filed for record in Book 248 Page 499, Fairbanks Recording District.

Excepting therefrom all portions of existing buildings and appurtenances thereof, if any; all existing public and private utilities and appurtenances thereof, inclusive of surface and subsurface utilities; signs, bollards, parking structures, if any, and all corporeal hereditaments of said property not appurtenant to existing sidewalks, existing disabled ramps, existing driveways, and those improvements specific to said State of Alaska DOT&PF Project No. Z632910000.

Said described parcel contains 1,532 square feet, more or less

which lies adjacent to right-of-way lines of Alaska Project No. Z63291000, delineated as to said tract of land on the plat attached hereto and made a part of hereof as pages 4, 5 & 6 of this instrument and designated as Parcel No. TCE-11. Said parcels, containing 1,532 square feet, more or less, to construct the Wendell Avenue Bridge project, is hereby granted to the State of Alaska for the purpose of workspace for a temporary work trestle, rebuild path and relocate a fire hydrant.

The Grantor hereby covenants with the State of Alaska that the Grantor has good title to the above-described tract of land, and covenants that the State of Alaska shall have quiet and peaceable possession thereof and use thereof during the period of the temporary construction easement. The period shall begin

on the day the contract is awarded and end on the completion of the project, not to exceed 2 years, at which time this easement shall expire and be of no force and effect.

GRANTOR  
City of Fairbanks

\_\_\_\_\_  
By: Jim Matherly  
Title: Mayor

ATTEST:

APPROVED AS TO FORM:

\_\_\_\_\_  
D. Danyielle Snider, CMC  
City Clerk

\_\_\_\_\_  
Paul Ewers  
City Attorney

**ACKNOWLEDGMENT**

THIS IS TO CERTIFY that on this \_\_\_\_\_ day of \_\_\_\_\_, 20\_\_, the undersigned, a Notary Public for the State of Alaska, duly commissioned and sworn as such, personally appeared JIM MATHERLY, and D. DANYIELLE SNIDER, and that they acknowledged before me that they executed the same for and on behalf of The City of Fairbanks and under the authority of said municipal corporation so granted by the City Council, as their free and voluntary act and deed of said corporation.

IN WITNESS, I have set my hand and affixed my official seal on this \_\_\_\_\_ day of \_\_\_\_\_, 20\_\_.

\_\_\_\_\_  
Notary Public  
My Commission Expires: \_\_\_\_\_

**CERTIFICATE OF ACCEPTANCE**

THIS IS TO CERTIFY that the STATE OF ALASKA, DEPARTMENT OF TRANSPORTATION AND PUBLIC FACILITIES, Grantee herein, acting by and through its Commissioner, hereby accepts for public purposes the real property, or interest therein, described in this instrument and consents to the recordation thereof.

IN WITNESS WHEREOF, I have hereunto set my hand this \_\_\_ day of \_\_\_\_\_, 2\_\_\_\_\_.

DEPARTMENT OF TRANSPORTATION AND PUBLIC FACILITIES

By: \_\_\_\_\_  
For the Commissioner

Filed for Record at the Request of and Return to:  
State of Alaska  
DOT&PF – Right of Way Dept.  
2301 Peger Road, MS 2553  
Fairbanks, AK 99709-5399  
State Business-No Charge



STATE OF ALASKA  
DEPARTMENT OF TRANSPORTATION  
&  
PUBLIC FACILITIES

**TEMPORARY CONSTRUCTION EASEMENT  
REQUIRED FOR  
WENDELL AVENUE BRIDGE  
PROJECT #Z632910000**

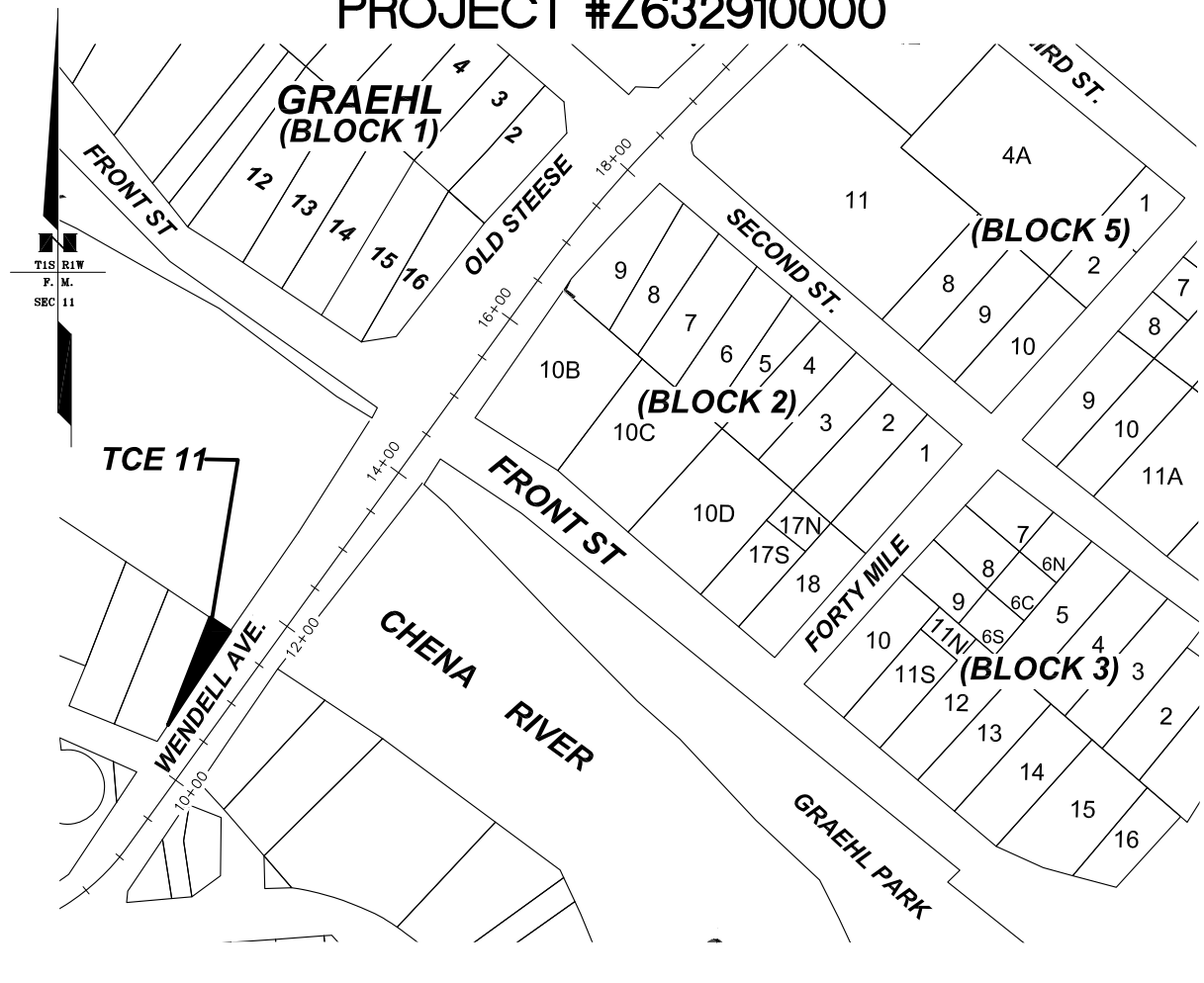

H:\ROWE\Eng\Hwys\63291-Wendell Street Bridge\C3D\TCE & TCP\WENDELL ST BRIDGE TCE TCP.dwg Jan 14, 2020 - 1:19pm

|  |            |  |                          |
|--|------------|--|--------------------------|
| STATE OF ALASKA<br>DEPARTMENT OF TRANSPORTATION<br>AND PUBLIC FACILITIES |            | TEMPORARY CONSTRUCTION EASEMENT<br>REQUIRED FOR<br>WENDELL AVENUE BRIDGE |                          |
|  | DRAWING    | PROJECT NO. <u>Z632910000</u>  |                          |
|  |            | AREA <u>1532 S.F.</u>  | PARCEL NO. <u>TCE 11</u> |
| INITIAL _____  | DATE _____ | SCALE <u>1" = 200'</u> DATE <u>01/14/2020</u>                            |                          |
| 1 OF 3   |            |  |                          |

H:\ROWE\Eng\Hwys\63291-Wendell Street Bridge\C3D\TCE & TCP\WENDELL ST BRIDGE TCE\_TCP.dwg Jan 14, 2020 - 1:28pm

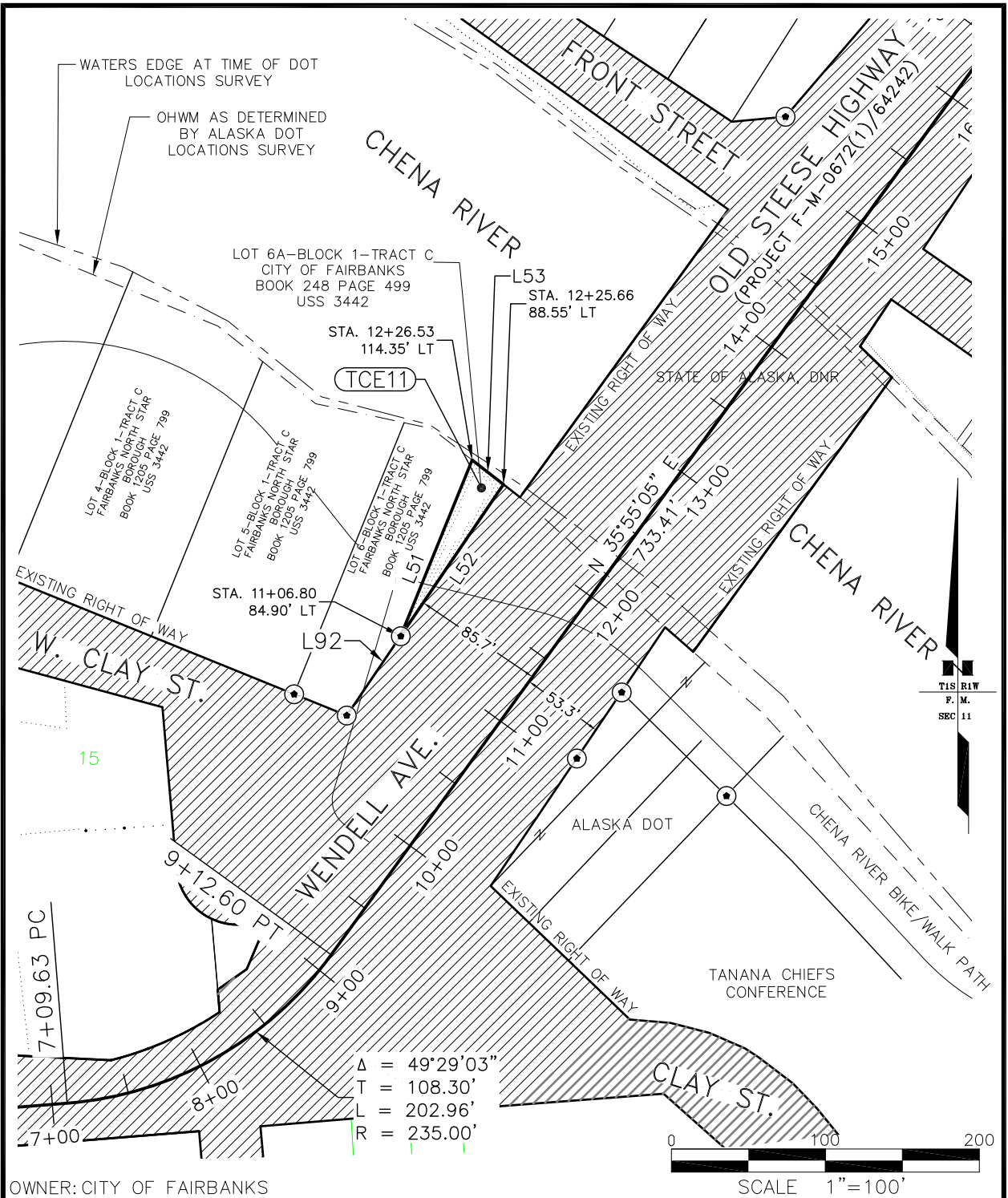

|  |         |  |                   |
|--|---------|--|-------------------|
| OWNER: CITY OF FAIRBANKS   |         | SCALE 1"=100'  |                   |
| STATE OF ALASKA<br>DEPARTMENT OF TRANSPORTATION<br>AND PUBLIC FACILITIES |         | TEMPORARY CONSTRUCTION EASEMENT<br>REQUIRED FOR<br>WENDELL AVENUE BRIDGE |                   |
| _____  | DRAWING | PROJECT NO. _____  | Z632910000        |
| _____  | 2 OF 3  | AREA _____   | PARCEL NO. TCE 11 |
| INITIAL  | DATE    | SCALE 1" = 100'  | DATE 01/14/2020   |

H:\ROWE\Eng\Hwys\63291-Wendell Street Bridge\C3D\TCE & TCP\WENDELL ST BRIDGE TCE\_TCP.dwg Jan 14, 2020 - 1:21pm

| LINE DATA |               |          |
|-----------|---------------|----------|
| L#        | BEARING       | DISTANCE |
| L51       | N 22°05'57" E | 123.29'  |
| L52       | S 34°09'42" W | 118.92'  |
| L53       | S 52°09'50" E | 25.82'   |
| L92       | N 34°07'05" E | 62.45'   |

OWNER: CITY OF FAIRBANKS

|  |                      |  |                          |
|--|----------------------|--|--------------------------|
| STATE OF ALASKA<br>DEPARTMENT OF TRANSPORTATION<br>AND PUBLIC FACILITIES |                      | TEMPORARY CONSTRUCTION EASEMENT<br>REQUIRED FOR<br>WENDELL AVENUE BRIDGE |                          |
| _____  | DRAWING              | PROJECT NO. <u>Z632910000</u>  |                          |
| _____  | AREA                 | <u>1532 S.F.</u>   | PARCEL NO. <u>TCE 11</u> |
| INITIAL  | DATE                 | SCALE <u>N/A</u>   | DATE <u>01/14/2020</u>   |
|  | <u>3</u> OF <u>3</u> |  |                          |



**RESOLUTION NO. 4908**

**A RESOLUTION AUTHORIZING THE CITY OF FAIRBANKS TO  
ACCEPT FUNDING FROM THE BUREAU OF JUSTICE ASSISTANCE  
FOR THE FFY2020 CORONAVIRUS EMERGENCY SUPPLEMENTAL  
FUNDING PROGRAM**

**WHEREAS**, the City of Fairbanks received notification of funding through the Bureau of Justice Assistance for the FFY2020 Coronavirus Emergency Supplemental Funding Program in the amount of \$76,460 to assist in preventing, preparing for, and responding to the coronavirus; and

**WHEREAS**, the City of Fairbanks will use the funds to cover the cost of personal protective equipment, supplies, and overtime required to address the coronavirus outbreak for law enforcement and emergency medical services; and

**WHEREAS**, the City of Fairbanks is not required to provide a match.

**NOW, THEREFORE, BE IT RESOLVED** by the City Council that the Mayor or his designee is authorized to execute any and all documents required for accepting funds on behalf of the City for this grant.

**PASSED and APPROVED this 13th Day of April 2020.**

\_\_\_\_\_  
**Jim Matherly, City Mayor**

AYES:  
NAYS:  
ABSENT:  
APPROVED:

ATTEST:

APPROVED AS TO FORM:

\_\_\_\_\_  
D. Danyielle Snider, CMC, City Clerk

\_\_\_\_\_  
Paul J. Ewers, City Attorney

**CITY OF FAIRBANKS**  
**FISCAL NOTE**

**I. REQUEST:**

Ordinance or Resolution No: 4908

Abbreviated Title: FFY2020 CORONAVIRUS EMERGENCY SUPP FUNDING PROGRAM (CESF)

Department(s): POLICE & FIRE

Does the adoption of this ordinance or resolution authorize:

1) additional costs beyond the current adopted budget? Yes \_\_\_\_\_ No X

2) additional support or maintenance costs? Yes \_\_\_\_\_ No X

If yes, what is the estimate? see below

3) additional positions beyond the current adopted budget? Yes \_\_\_\_\_ No X

If yes, how many positions? \_\_\_\_\_

If yes, type of positions? \_\_\_\_\_ (F - Full Time, P - Part Time, T - Temporary)

**II. FINANCIAL DETAIL:**

| <b>PROJECTS:</b>                         | <b>Equipment</b> | <b>Training</b> | <b>Personnel</b> | <b>Total</b>    |
|--|------------------|-----------------|------------------|-----------------|
| Personal Protective Equipment & Supplies | \$60,000         |                 |                  | \$60,000        |
| Police & Fire Overtime                   |                  |                 | \$16,460         | \$16,460        |
|  |                  |                 |                  |                 |
|  |                  |                 |                  |                 |
| <b>TOTAL</b>                             | <b>\$60,000</b>  | <b>\$0</b>      | <b>\$16,460</b>  | <b>\$76,460</b> |

| <b>FUNDING SOURCE:</b>                       | <b>Equipment</b> | <b>Training</b> | <b>Personnel</b> | <b>Total</b>    |
|--|------------------|-----------------|------------------|-----------------|
| Bureau of Justice Assistance (Federal Funds) | \$60,000         | \$0             | \$16,460         | \$76,460        |
|  |                  |                 |                  |                 |
| <b>TOTAL</b>                                 | <b>\$60,000</b>  | <b>\$0</b>      | <b>\$16,460</b>  | <b>\$76,460</b> |

This grant will cover costs associated with the coronavirus outbreak and will not result in on-going operations and maintenance costs.

Reviewed by Finance Department:

Initial cp

Date 4/2/2020

**ORDINANCE NO. 6129**

**AN ORDINANCE RE-ESTABLISHING AN INCENTIVE BONUS PROGRAM WITHIN THE FAIRBANKS POLICE DEPARTMENT FOR RECRUITMENT AND HIRING**

**WHEREAS**, Ordinance No. 6050, as Amended, passed by the City Council in June of 2017, approved an incentive bonus program within the Fairbanks Police Department (the Department) for recruitment and hiring to address the significant shortfall in police officer staffing; and

**WHEREAS**, the sunset date for the bonus program, originally July 1, 2018, was extended until December 19, 2019, by Resolution No. 4832; and

**WHEREAS**, the reasons for providing a bonus to lateral hires were: (1) the cost to the City of sending an officer to the Police Academy (approximately \$30,000); and (2) a one-time, sign-on bonus of \$20,000 for a lateral hire would help attract applicants and would constitute a significant cost savings to the City; and

**WHEREAS**, while the bonus program has helped in attracting lateral hires, the Department's staffing levels continue to be a challenge due to retirements and transfers; and

**WHEREAS**, the Council finds that there continues to be a need for the bonus program; and

**WHEREAS**, the Department continues to have salary savings from unfilled positions that will fund the bonus program.

**NOW, THEREFORE, BE IT ENACTED BY THE CITY COUNCIL OF THE CITY OF FAIRBANKS, ALASKA, as follows:**

**SECTION 1.** An incentive bonus program for recruitment and hiring within the Fairbanks Police Department is hereby approved as follows:

- (a) An applicant who is a certified police officer in the State of Alaska or is able to meet Alaska Police Standards Council (APSC) certification standards without attending a basic officer academy will be paid a \$20,000 "sign-on bonus" in their first paycheck following completion of Field Training, subject to the payback provisions specified in the attached Sign-on Bonus Agreement.



- (b) If an active FPD employee recruits a new officer, as defined in subsection (a), who successfully completes the hiring process, the employee will receive a recruitment bonus of \$5,000.

**SECTION 2.** The bonuses established in Section 1 may only be funded by salary savings from unfilled, budgeted positions, if available.

**SECTION 3.** The bonus program created by this ordinance will apply retroactively to January 1, 2020 and will sunset on June 30, 2021, unless extended by Resolution of the City Council.

---

**Jim Matherly, City Mayor**

AYES:  
NAYS:  
ABSENT:  
ADOPTED:

ATTEST:

APPROVED AS TO FORM:

---

D. Danyielle Snider, CMC, City Clerk

---

Paul J. Ewers, City Attorney

**CITY OF FAIRBANKS  
FISCAL NOTE**

**I. REQUEST:**

Ordinance or Resolution No: 6129

Abbreviated Title: POLICE DEPARTMENT INCENTIVE BONUS

Department(s): POLICE DEPARTMENT

Does the adoption of this ordinance or resolution authorize:

1) additional costs beyond the current adopted budget? Yes \_\_\_\_\_ No X

2) additional support or maintenance costs? Yes \_\_\_\_\_ No X

If yes, what is the estimate? see below

3) additional positions beyond the current adopted budget? Yes \_\_\_\_\_ No X

If yes, how many positions? \_\_\_\_\_

If yes, type of positions? \_\_\_\_\_ (F - Full Time, P - Part Time, T - Temporary)

**II. FINANCIAL DETAIL:**

| <b>EXPENDITURES:</b> | <b>2020</b> | <b>2021</b> | <b>2022</b> | <b>Total</b> |
|----------------------|-------------|-------------|-------------|--------------|
| FPD SALARY AND WAGES |             |             |             | \$0          |
|                      |             |             |             | \$0          |
|                      |             |             |             | \$0          |
|                      |             |             |             | \$0          |
|                      |             |             |             |              |
| <b>TOTAL</b>         | <b>\$0</b>  | <b>\$0</b>  | <b>\$0</b>  | <b>\$0</b>   |

| <b>FUNDING SOURCE:</b> | <b>2020</b> | <b>2021</b> | <b>2022</b> | <b>Total</b> |
|------------------------|-------------|-------------|-------------|--------------|
| GENERAL FUND           |             |             |             | \$0          |
|                        |             |             |             |              |
| <b>TOTAL</b>           | <b>\$0</b>  | <b>\$0</b>  | <b>\$0</b>  | <b>\$0</b>   |

All incentive bonuses will be paid using unspent wages in the current budget.

Reviewed by Finance Department: Initial mb Date 4/7/2020



Fairbanks Police Department  
**Sign-On Bonus Contract**

This agreement is made between the CITY OF FAIRBANKS (“City”) and \_\_\_\_\_ (“Employee”).

WHEREAS, this contract will apply to an Employee who begins employment for the City in the Police Department (“Department”) for the first time as a POLICE OFFICER and meets the City requirements as a lateral-hire Police Officer; and

WHEREAS, the Department wishes to bestow upon the Employee a “Sign-on Bonus” as an incentive for the Employee to accept employment at the City and to remain satisfactorily employed in the Department for at least three full years;

THEREFORE, the City and the Employee agree to the following terms:

1. The City, acting through the Department, agrees to bestow upon the Employee the amount of \$20,000.00 as a Sign-on Bonus in return for the Employee accepting the City’s offer of employment. This amount shall be paid directly to the Employee on the Employee’s first paycheck following the successful completion of field training.
2. The City will apply all required federal and state tax deductions and will report all payments made under this Agreement as required by federal and state law. Taxes shall be withheld as bonus earnings from the Sign-on Bonus and reported to the Internal Revenue Services as income on the Employee’s Form W-2. The Sign-on Bonus is not considered “salary” and shall not be included for purposes of retirement benefit calculations or salary increases.
3. The Department will adhere to all relevant City and Department policies during the hiring process and in making bonus payments to employees.
4. In return for accepting the Sign-on Bonus as provided in paragraphs 1 and 2 above, the Employee agrees to work for the Department on a regular and full-time basis for at least three years beginning “Start Date” and ending on “3 Year Date”. Should the Employee resign, quit, or be terminated for cause before the above stated ending date, the Employee shall repay a prorated amount of the Sign-on Bonus as provided in the following paragraphs.
5. The Employee’s failure to remain employed by the Department for three years will trigger the Employee’s duty to repay, pro-rata, the amount paid by the City pursuant to paragraph 1, above. (This amount may be more than the Employee received due to tax or other withholdings.) For example, if the Employee leaves one year prior to the end date, they will repay 12/36 of such amount. To facilitate this repayment, the Employee, by signing below, expressly gives the City a lien on their salary, wages, and other sums payable to them by the City. In addition, the Employee hereby authorizes the City to withhold all amounts so due from any sum payable to the Employee by the Department or the City. The Employee also agrees that any tax consequences resulting from the repayment of the Sign-on Bonus or any portion thereof will be the sole and exclusive responsibility of the Employee.



6. If the Employee fails to remain employed by the Department for three years for reasons beyond their control (e.g. injury, illness or death), other than just cause termination, the Department may in its sole discretion waive all or part of the liability owed by the Employee. Any such waivers must be approved in writing by both the Chief of Police and the Mayor.
  
7. If any part of the Agreement is found to be invalid or unenforceable, the other parts shall remain valid and enforceable and Employee agrees, represents, and warrants that they will be held to any applicable repayment of the Sign-on Bonus.

BY SIGNING BELOW, the Employee certifies that they have not accepted a financial incentive for accepting employment at the City, other than as described in this Agreement.

IN WITNESS THEREOF:

\_\_\_\_\_  
Employee Signature

\_\_\_\_\_  
Date

\_\_\_\_\_  
Chief of Police Signature

\_\_\_\_\_  
Date

\_\_\_\_\_  
Mayor Signature

\_\_\_\_\_  
Date

cc: Personnel File